

Product Catalog 2008

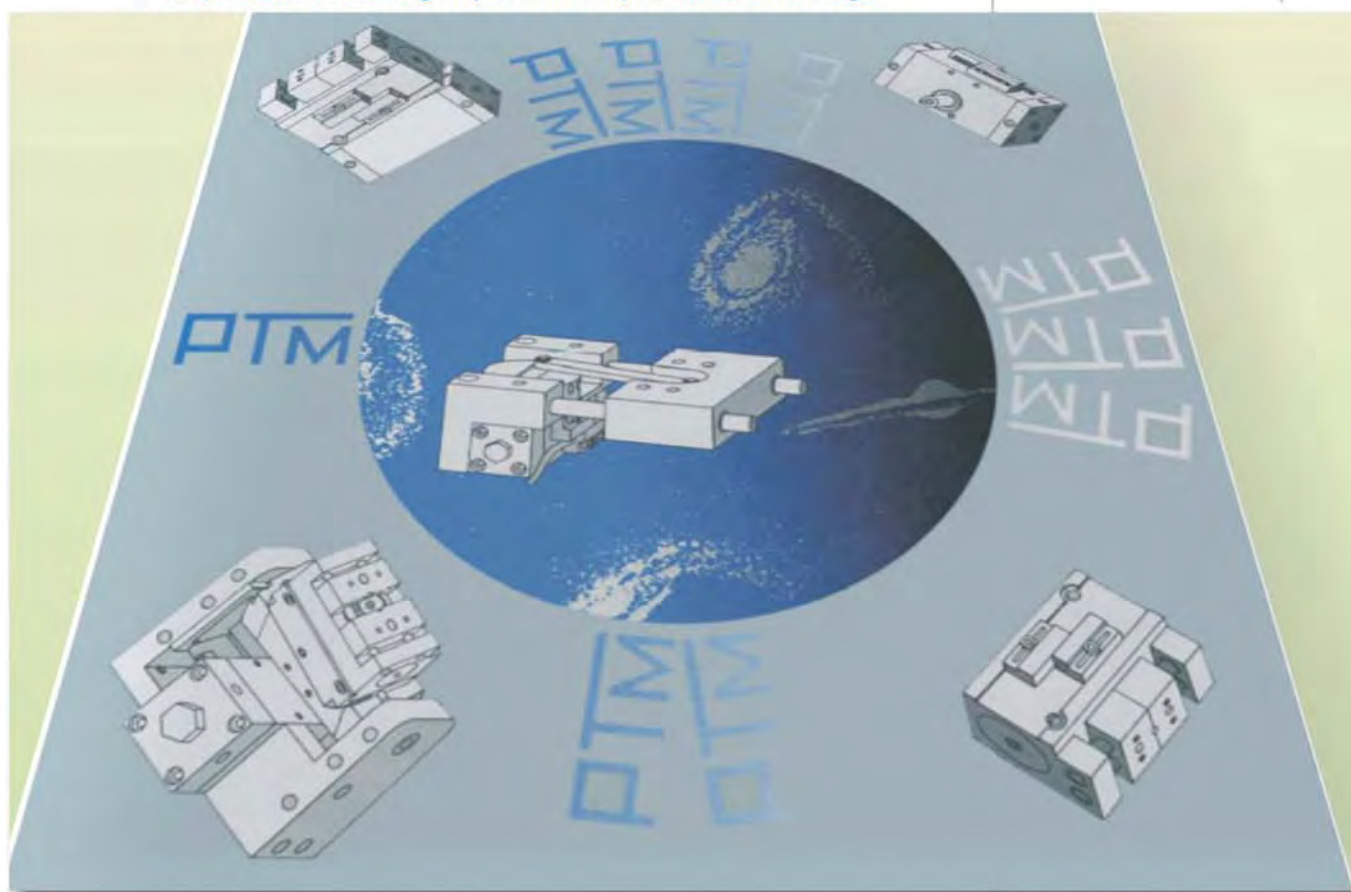

This product catalog replaces all previous catalogs



P.T.M. – PRODUKTION
technisch-mechanischer
Geräte GmbH

PTM Rotary Actuators and Parallel Grippers on 2D- and 3D- format

For design engineering support we offer our complete product range on 2D- and 3D- format, on scale 1:1, metric dimensions.

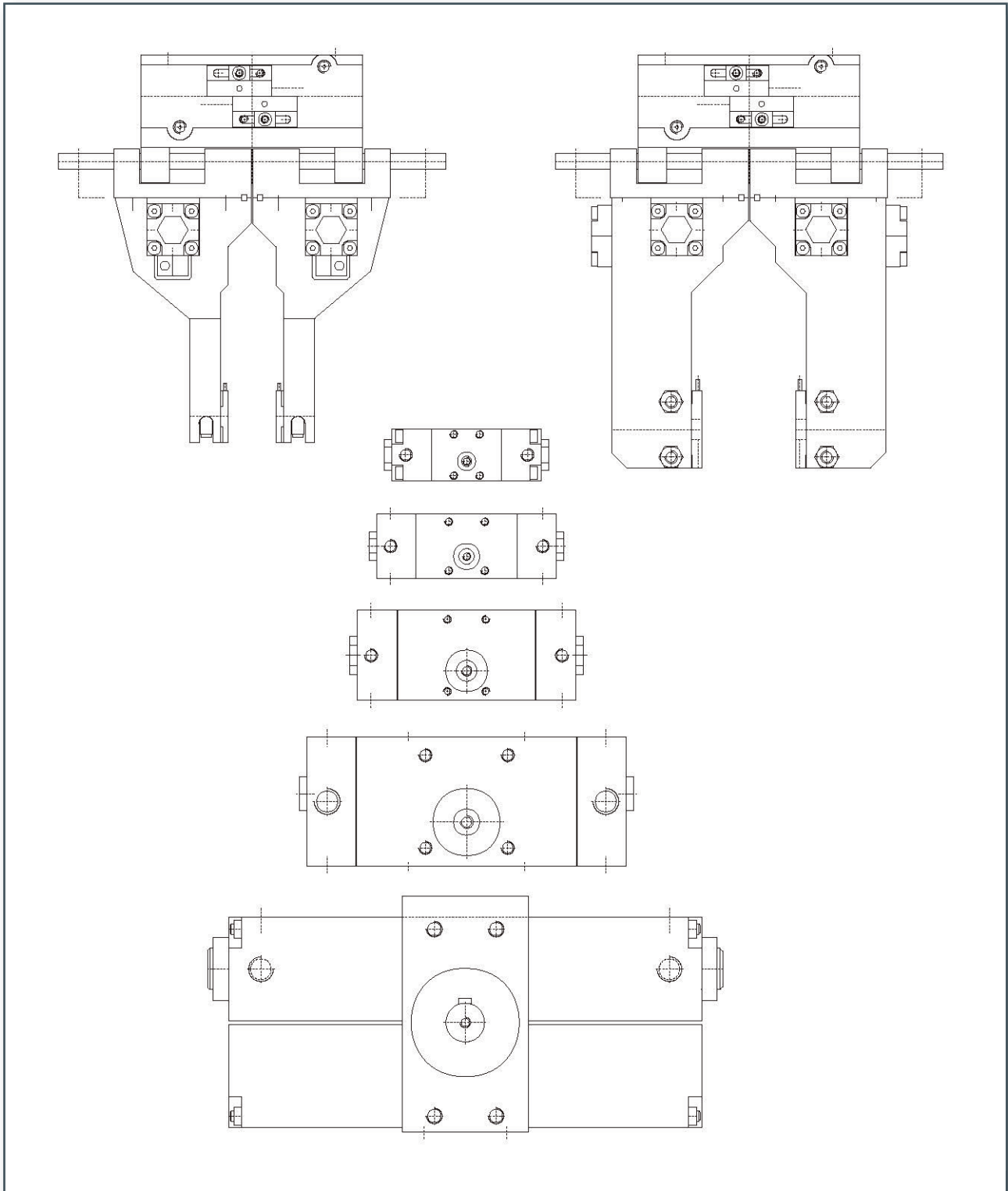

We are constantly working to improve our products. Therefore, we reserve the right for technical changes.
All dimensions in mm, general tolerances DIN 7168 medium.

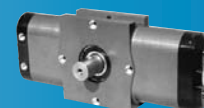

PTM Pneumatic Mini Actuators	DA	4
PTM Pneumatic Actuators	DA	8
PTM Pneumatic Rotary Modules	DM	10
Shaft – Hub Connection for DA, Hub flange for HPA	ZAF	12
PTM Three Position Torque Cylinders	DAD	13
PTM Hydraulic-Pneumatic Rotary Actuators	HPA	16
PTM Hydraulic-Pneumatic Multi Position Cylinder, Rotary Switching Drive	HPAD	20

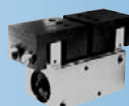

PTM Pneumatic Parallel Grippers	PSM	22
PTM Pneumatic Parallel Grippers with u-shaped Jaws	PSMU	28
PTM-Three-Pivot-Finger Gripper	DSG	32
PTM Parallel Tilting Grippers	PSZ	34
Several Positions Cylinders, Mounting Hole for Ejector	ZMZ	42
Spring Force, Attachement for Centering	ZFS	43
PTM End Position Switches as replacement parts		44

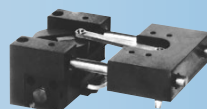

Informations about LM, SM, DSK		45
PTM Linear-Modules	LM	46
PTM Tilting Modules	SM	48
PTM Double Tilting Heads	DSK	49



PTM Swivel Distributor, Power Distribution	SLE 1014	52
PTM Formulas		54
General Terms an Conditions of Business		55

Pneumatic Actuators

DA 0020, DA 0050, DA 0200, DA 0500

DA 1500, DA 3000, DA 6000

All PTM-actuators are based on the rack-and pinion principle, picture 2.

This fact is responsible for small dimensions. For different mounting alternatives all PTM-actuators can be mounted on three or four mounting surfaces.

Rotation angles more than 185° are available.

Our progressive working end position damping starts working just about 10° before reaching the end position by throttling the exhaust air automatically. This guarantees reaching the exact end position. This excludes bouncing in the end position even during air pressure variation.

A technically necessary backlash of $0,5^\circ$ is unavoidable at Mini-Actuators with rack-and pinion principle.

Main characteristics of our actuators are small dimensions, low weight and long lifetime. The power transmission is placed in the centerline of the rack piston to guarantee a very long lifetime. There are PTM-actuators which were returned for repair only after 13 years of continuous running.

The smallest Pneumatic Mini Actuator DA 0020 with rotation angle of 95° and a torque of 20 Ncm, has the dimensions of only 20x20x43 mm and a weight of 0,050 kg. These small dimensions and weights allow you to increase the performance-weight ratio of your robot or other applications.

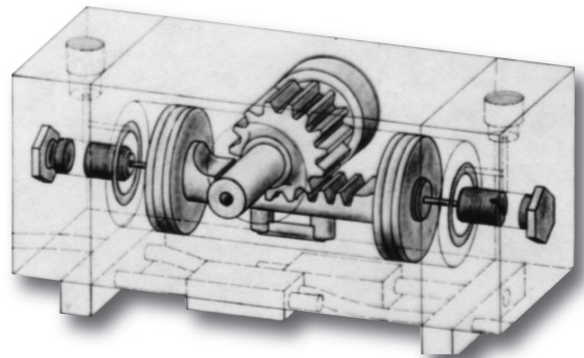

picture 2

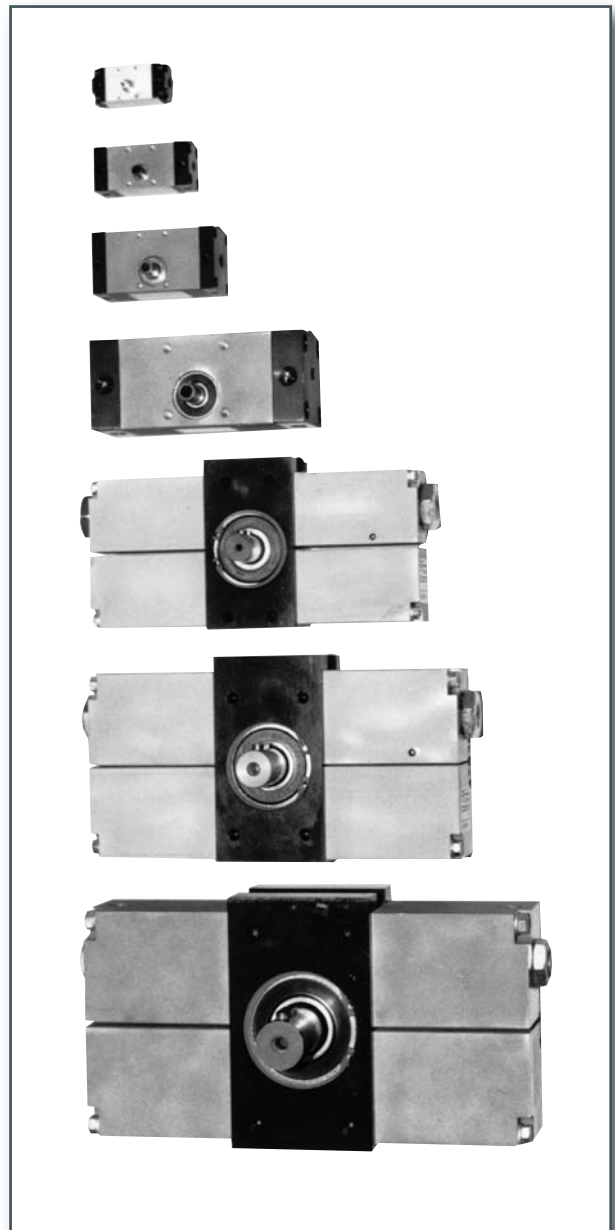

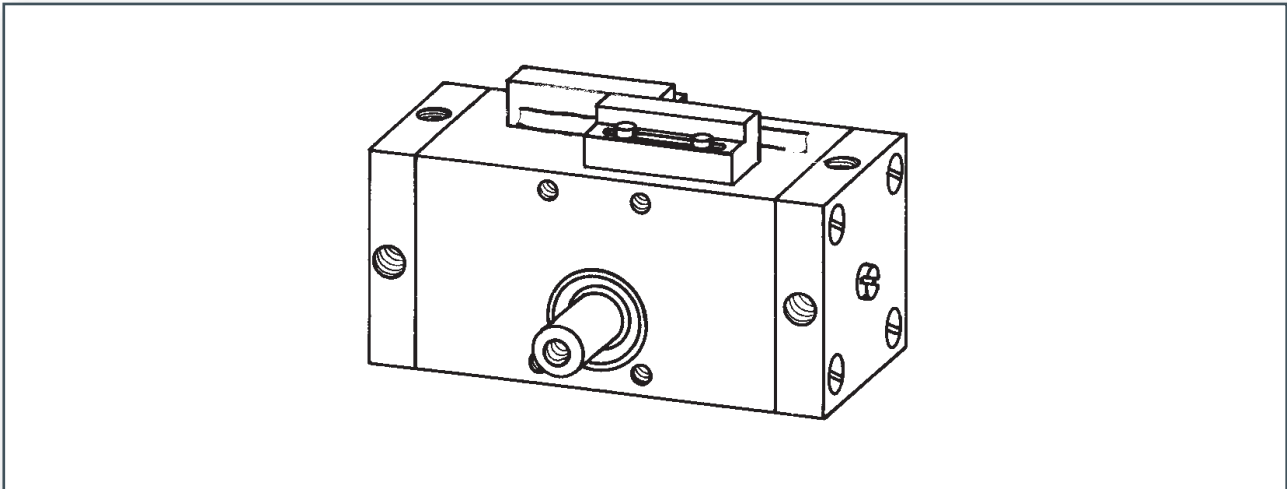

Material:	<ul style="list-style-type: none"> - aluminum hard or black anodized - steel parts of stainless material or corrosion resistant - short time gas nitration
Operation / mounting position:	<ul style="list-style-type: none"> - any position desired
Operating temperature:	<ul style="list-style-type: none"> - -10° to +80° C (14° to 176° F)
Operating media:	<ul style="list-style-type: none"> - filtered oiled or filtered oil-free air - Attention: Only oil-free air should be used at low rotation speed to guarantee smooth movement.
Maintenance:	<ul style="list-style-type: none"> - all PTM Pneumatic Actuators are maintenance-free.
Operating pressure:	<ul style="list-style-type: none"> - maximum 8 bar = 118 psi (specs are based on 6 bar = 88 psi)
Rotation angle:	<ul style="list-style-type: none"> - rotation angle max. 365°, 185° and 95° - adjustable until -20° in total by adjustment screws
Shaft-hub connection:	<ul style="list-style-type: none"> - if possible use keyway/key, if not use Loctite 601 for mounting of smaller masses on the shaft - combination of clamping with set screw and Loctite 601 (avoid under all circumstances boring the shaft) - shrink or press fit h6/P5 or R6 - clamping unit „Rfn 8006“ from Ringfeder Corporation
End position control with LED:	<ul style="list-style-type: none"> - please consult our sheet „end position control“ on page 44
End position damping:	<ul style="list-style-type: none"> - progressive damping characteristics, the angle remains adjustable
End position:	<ul style="list-style-type: none"> - the technically necessary backlash (until model DA 0500) must be eliminated by external stops when highly accurate end positions are required. This is also possible with an external stop on a second shaft.
Installation recommendation:	<ul style="list-style-type: none"> - to ensure long life of our devices the use of throttle valves is highly recommended.

Pneumatic Mini Actuator

DA 0020, DA 0050, DA 0200, DA 0500

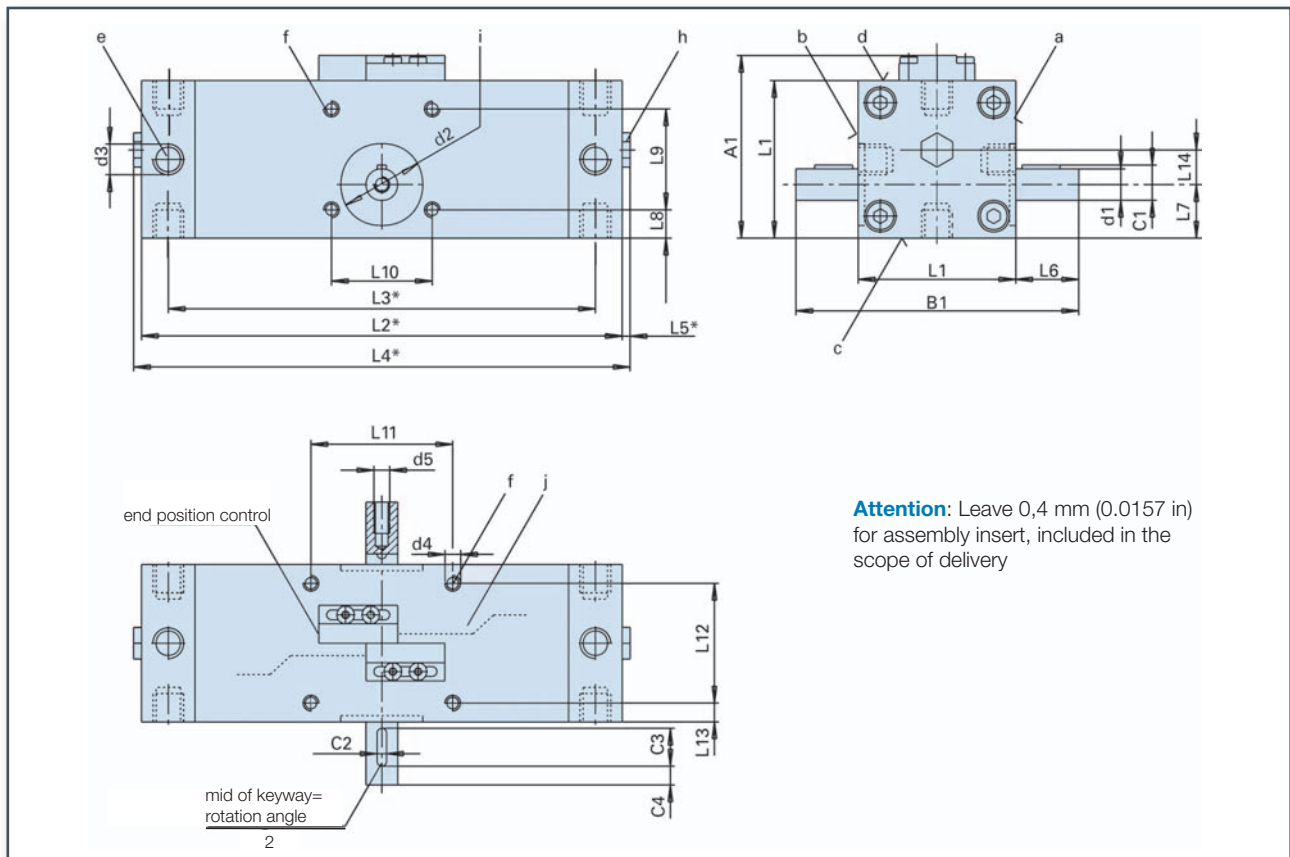

Attention: Leave 0,4 mm (0.0157 in) for assembly insert, included in the scope of delivery

- a, b, c** mounting surface for model DA 0020, DA 0050, and DA 0200
- a, b, c, d** mounting surface for model DA 0500
- e** 4 threaded holes per head plate for air connection and mounting alternatives
- f** 4 threaded holes for model DA 0020, DA 0050 and DA 0200 on side a and b for mounting alternatives
4 threaded holes for model DA 0500 on side a, b, c, d for mounting alternatives
- h** adjustment screw to limit the rotation angle (model with end position damping under cover screw)
- i** centre bore
- j** connection cable for end position control
- *** model with or without end position damping
- A** model with end position control
- B** model with 2 shaft ends
- C** model with keyway/key

Ordering Code

DA	0020	-	XXX	-	X	-	X
DA	0050	-	XXX	-	X	-	X
DA	0200	-	XXX	-	X	-	X
DA	0500	-	XXX	-	X	-	X

torque at 6 bar in Ncm rotation angle

Ordering Example **you order:** DA 0500 - 185 - 2 - 1

we deliver: Pneumatic Actuator model DA 0500 with rotation angle max. 185° with end position damping 1 shaft end with keyway/key

- 0 = basic model
- 1 = with end position control
- 2 = with end position damping
- 3 = with 1 and 2
- 0 = 1 shaft end straight, basic model
- 1 = 1 shaft end with keyway/key
- 2 = 2 shaft ends/ 1 straight, 1 side with keyway/key
- 3 = 2 shaft ends, 2 x keyway/key
- 4 = 2 shaft ends straight

All dimensions in mm

DA	0020-095	0020-185	0020-365	0050-095	0050-185	0050-365
rotation angle	95°	185°	365°	95°	185°	365°
ø d1	4 h6	4 h6	4 h6	6 h6	6 h6	6 h6
ø d2	7 J7x0,5	7 J7x0,5	7 J7x0,5	10 J7x0,5	10 J7x0,5	10 J7x0,5
d3	M5x4	M5x4	M5x4	M5x4,5	M5x4,5	M5x4,5
d4	M3x4	M3x4	M3x4	M3x5	M3x5	M3x5
d5	M3x5,5	M3x5,5	M3x5,5	M3x5,5	M3x5,5	M3x5,5
L1	20	20	20	25	25	25
L2 without end position damping	43,3 +0,4 -0,6	52,8 +0,4 -0,6	67,4 +0,4 -0,6	55,2 +0,4 -0,6	67,2 +0,4 -0,6	92,2 +0,4 -0,6
L2 with end position damping	58,1 +0,4 -0,6	67,6 +0,4 -0,6	82,2 +0,4 -0,6	70,0 +0,4 -0,6	82,0 +0,4 -0,6	107,0 +0,4 -0,6
L3 without end position damping	35,3 +0,2 -0,4	44,8 +0,2 -0,4	59,4 +0,2 -0,4	47,2 +0,2 -0,4	59,2 +0,2 -0,4	84,2 +0,2 -0,4
L3 with end position damping	47,3 +0,4 -0,2	56,8 +0,4 -0,2	71,4 +0,4 -0,2	59,2 ±0,4	71,2 ±0,4	96,2 ±0,4
L4 without end position damping	—	—	—	—	—	—
L4 with end position damping	63,7 +0,6 -0,8	73,2 +0,6 -0,8	87,8 +0,6 -0,8	75,6 +0,6 -0,8	87,6 +0,6 -0,8	112,6 +0,6 -0,8
L5 without end position damping	—	—	—	—	—	—
L5 with end position damping	2,8	2,8	2,8	2,8	2,8	2,8
L6	10	10	10	9	9	9
L7	7,5	7,5	7,5	8,5	8,5	8,5
L8	2	2	2	3	3	3
L9	16	16	16	19	19	19
L10	10	10	10	14	14	14
A1	29,5 ±0,5	29,5 ±0,5	29,5 ±0,5	33 ±0,4	33 ±0,4	33 ±0,4
B1	40	40	40	43	43	43
C1	—	—	—	6,8	6,8	6,8
C2	—	—	—	2 N9	2 N9	2 N9
C3	—	—	—	6	6	6
C4	—	—	—	2	2	2
F _A axial N	20	20	20	55	55	55
C _O radial N	90	90	90	220	220	220
weight in kg	0,050	0,060	0,075	0,10	0,12	0,15
compressed air/stroke in cm ³	0,7	1,4	2,8	1,6	3,2	6,4
DA	0200-095	0200-185	0200-365	0500-095	0500-185	0500-365
rotation angle	95°	185°	365°	95°	185°	365°
ø d1	8 h6	8 h6	8 h6	10 h6	10 h6	10 h6
ø d2	16 J7x0,5	16 J7x0,5	16 J7x0,5	26 J7x0,8	26 J7x0,8	26 J7x0,8
d3	M5x5,5	M5x5,5	M5x5,5	R1/8x8	R1/8x8	R1/8x8
d4	M3x7	M3x7	M3x7	M5x11	M5x11	M5x11
d5	M4x9	M4x9	M4x9	M5x10	M5x10	M5x10
L1	35	35	35	50	50	50
L2 without end position damping	70,2 +0,4 -0,6	89,2 +0,4 -0,6	127,2 +0,4 -0,6	120,2 +0,4 -0,6	153,2 +0,4 -0,6	219,2 +0,4 -0,6
L2 with end position damping	85,0 +0,4 -0,6	104,0 +0,4 -0,6	142,0 +0,4 -0,6	124,0 +0,4 -0,6	157,0 +0,4 -0,6	223,0 +0,4 -0,6
L3 without end position damping	62,2 +0,2 -0,4	81,2 +0,2 -0,4	119,2 +0,2 -0,4	103,2 +0,2 -0,4	136,2 +0,2 -0,4	202,2 +0,2 -0,4
L3 with end position damping	74,2 ±0,4	93,2 ±0,4	131,2 ±0,4	108,2 ±0,4	141,2 ±0,4	207,2 ±0,4
L4 without end position damping	—	—	—	—	—	—
L4 with end position damping	90,6 +0,6 -0,8	109,6 +0,6 -0,8	147,6 +0,6 -0,8	129,6 +0,6 -0,8	162,6 +0,6 -0,8	228,6 +0,6 -0,8
L5 without end position damping	—	—	—	—	—	—
L5 with end position damping	2,8	2,8	2,8	2,8	2,8	2,8
L6	15	15	15	20	20	20
L7	11,5	11,5	11,5	17	17	17
L8	3,5	3,5	3,5	7	7	7
L9	28	28	28	36	36	36
L10	15	15	15	32	32	32
L11	—	—	—	45	45	45
L12	—	—	—	38	38	38
L13	—	—	—	6	6	6
L14	—	—	—	11	11	11
A1	43 ±0,4	43 ±0,4	43 ±0,4	58 ±0,4	58 ±0,4	58 ±0,4
B1	65	65	65	89,8	89,8	89,8
C1	8,8	8,8	8,8	11,2	11,2	11,2
C2	2 N9	2 N9	2 N9	3 N9	3 N9	3 N9
C3	8	8	8	12	12	12
C4	5	5	5	6	6	6
F _A axial N	180	180	180	470	470	470
C _O radial N	770	770	770	1900	1900	1900
weight in kg	0,25	0,33	0,4	0,8	1,0	1,3
compressed air/stroke in cm ³	6,4	11,9	23,5	13,9	27,2	53,7

Pneumatic Actuator

DA 1500, DA 3000, DA 6000

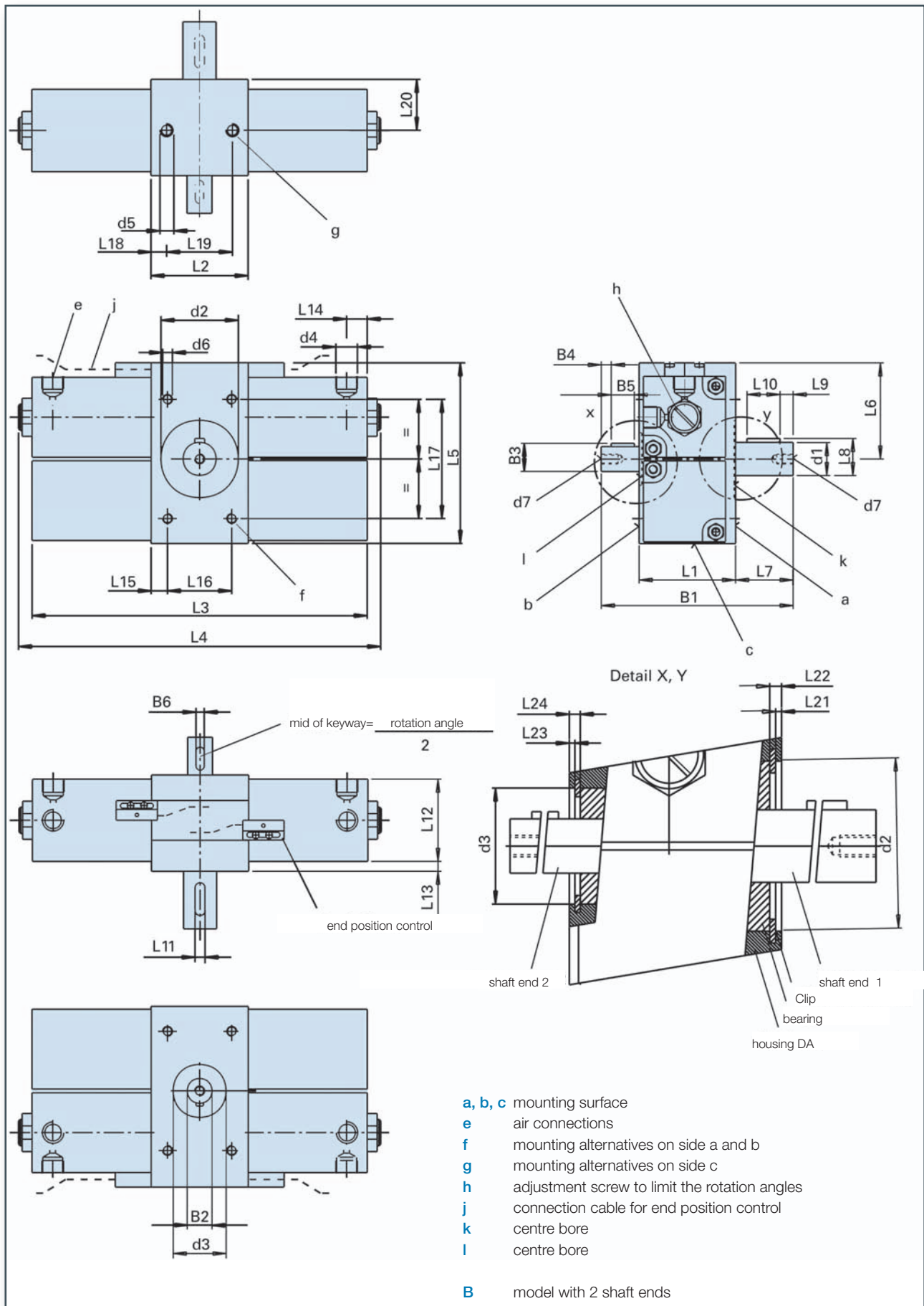

DA	1500-095	1500-185	1500-365	3000-095	3000-185	3000-365	6000-095	6000-185	6000-365
rotation angle	95°	185°	365°	95°	185°	365°	95°	185°	365°
ø d1	15 h6	15 h6	15 h6	20 h6	20 h6	20 h6	25 h6	25 h6	25 h6
ø d2	42 J7	42 J7	42 J7	47 J7	47 J7	47 J7	62 J7	62 J7	62 J7
ø d3	28 J7	28 J7	28 J7	32 J7	32 J7	32 J7	47 J7	47 J7	47 J7
d4	R1/8x9	R1/8x9	R1/8x9	R1/4x9	R1/4x9	R1/4x9	R1/4x9	R1/4x9	R1/4x9
d5	M8x9	M8x9	M8x9	M8x9	M8x9	M8x9	M10x12	M10x12	M10x12
d6	M6x10	M6x10	M6x10	M6x10	M6x10	M6x10	M8x13	M8x13	M8x13
d7	M4x6	M4x6	M4x6	M6x10	M6x10	M6x10	M8x12	M8x12	M8x12
L1	49	49	49	58,5	58,5	58,5	76	76	76
L2	49	49	49	59	59	59	76	76	76
L3	183,6	237	343,8	203,6	264,8	387,4	241	321	485
L4	200	253,4	360,2	220	281,2	403,8	257,4	337,4	501,4
L5	91,5	91,5	91,5	109,9	109,9	109,9	133	133	133
L6	48,9	48,9	48,9	58,5	58,5	58,5	69	69	69
L7	23	23	23	35	35	35	50	50	50
L8	17	17	17	22,5	22,5	22,5	28	28	28
L9	6	6	6	8	8	8	10	10	10
L10	14	14	14	20	20	20	25	25	25
L11	5 N9	5 N9	5 N9	6 N9	6 N9	6 N9	8 N9	8 N9	8 N9
L12	40x40	40x40	40x40	50x50	50x50	50x50	60x60	60x60	60x60
L13	7	7	7	6	6	6	8	8	8
L14	12,5	12,5	12,5	12,5	12,5	12,5	12,5	12,5	12,5
L15	12,5	12,5	12,5	10	10	10	13	13	13
L16	24	24	24	39	39	39	50	50	50
L17	72,5	72,5	72,5	72,5	72,5	72,5	100	100	100
L18	8,5	8,5	8,5	9,5	9,5	9,5	13	13	13
L19	32	32	32	40	40	40	50	50	50
L20	27	27	27	31	31	31	38	38	38
L21	1	1	1	1	1	1	2,15	2,15	2,15
L22	3	3	3	3	3	3	5,1	5,1	5,1
L23	1,2	1,2	1,2	1,7	1,7	1,7	2,2	2,2	2,2
L24	2,6	2,6	2,6	3,1	3,1	3,1	4,2	4,2	4,2
B1	92	92	92	116,5	116,5	116,5	161	161	161
ø B2	12 h6	12 h6	12 h6	15 h6	15 h6	15 h6	20 h6	20 h6	20 h6
B3	13,5	13,5	13,5	17	17	17	22,5	22,5	22,5
B4	5	5	5	6	6	6	8	8	8
B5	12	12	12	14	14	14	20	20	20
B6	4 N9	4 N9	4 N9	5 N9	5 N9	5 N9	6 N9	6 N9	6 N9
F _A axial N	550	550	550	1000	1000	1000	5000	5000	5000
C _o radial N	2200	2200	2200	6550	6550	6550	10000	10000	10000
weight in kg	1,56	1,9	2,2	2,7	3,2	4,5	4,6	5,5	7,2
compressed air/stroke in cm ³	22,6	44,1	87,1	44,7	87,2	172,0	91,5	178,1	351,6

All dimensions in mm

Ordering Code

DA	1500	-XXX	-X	-X
DA	3000	-XXX	-X	-X
DA	6000	-XXX	-X	-X

torque at 6 bar in Ncm

rotation angle

Ordering Example

you order:
DA 1500-095-0-1

we deliver:
Pneumatic Actuator model DA 1500 with rotation angle 95° basic model, with 1 shaft end

0 = basic model
1 = with end position control (sheet "end position control")
2 = with end position damping
3 = with 1 and 2

1 = 1 shaft end (d1) basic model
3 = 2 shaft ends (B2)

Rotary Module

DM 0020, DM 0050, DM 0200, DM 0500

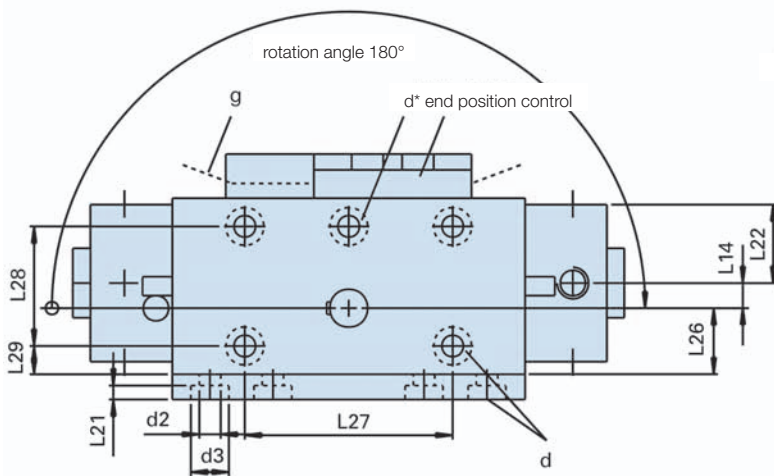
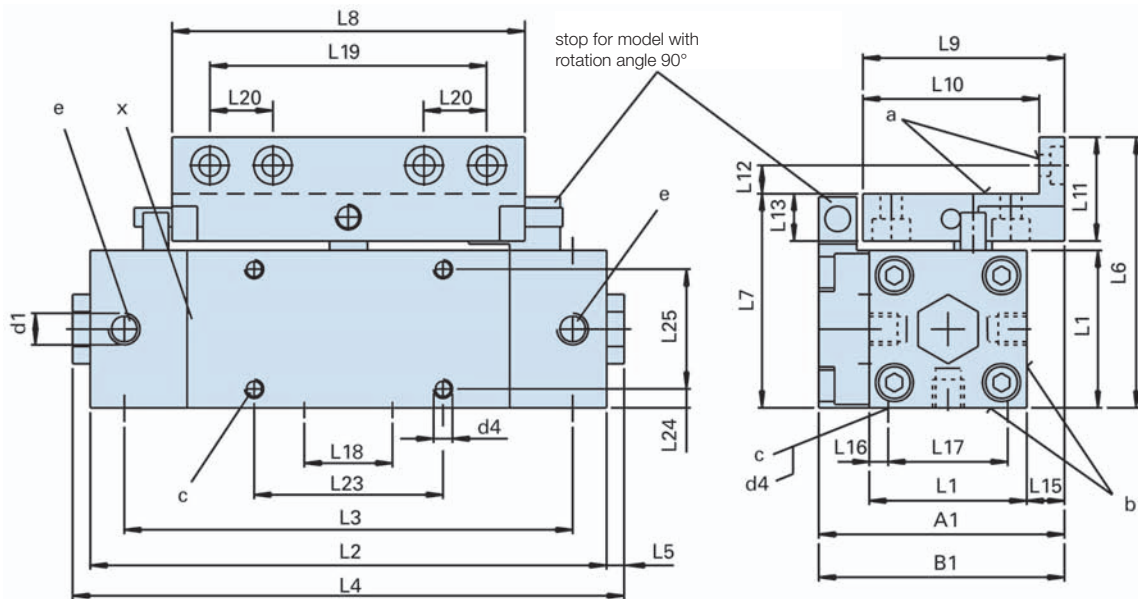

d* bore pattern only for DM 0020

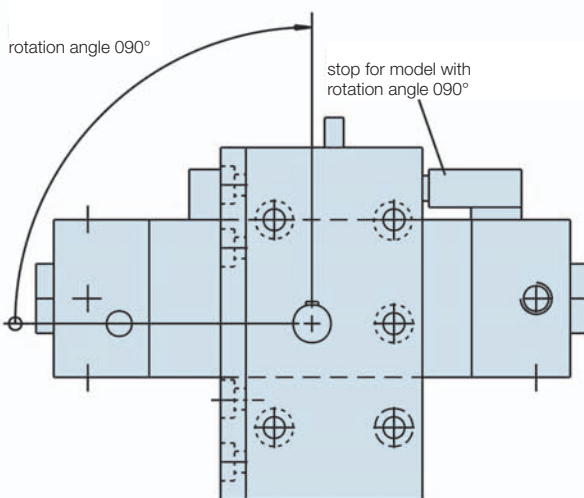

- a** mounting surface for additional turning equipment
- b** mounting surface
- c** mounting alternative
- d** bores for mounting of additional equipment
- e** 3 or 4 threaded holes for air connection and mounting alternatives
- g** connection cable for end position control

- A** model with end position control
- B** model with rotation angle 90°
- X** model of actuator

model	DM 0020	DM 0050	DM 0200	DM 0200	DM 0500
suitable for:	PSM 0030-007	PSM 0050-011	PSM 0200-013	PSM 0600-016	PSM 0600-016
X	DA 0020-185	DA 0050-185	DA 0200-185	DA 0200-185	DA 0500-185
d1	M5x4	M5x4,5	M5x5,5	M5x5,5	R1/8x8
ø d2	3,4	3,4	3,4	4,4	4,5
ø d3	6	6	6	8	8
d4	M3x4	M3x5	M3x7	M3x7	M5x11
L1	20	25	35	35	50
L2	67,6 +0,4 -0,6	82 +0,4 -0,6	104 +0,4 -0,6	104 +0,4 -0,6	157 +0,4 -0,6
L3	56,8 +0,4 -0,4	71,2 +0,4 -0,4	93,4 +0,4 -0,4	93,4 +0,4 -0,4	141,2 +0,4 -0,4
L4	73,2 +0,6 -0,8	87,6 +0,6 -0,8	109,6 +0,6 -0,8	109,6 +0,6 -0,8	162,6 +0,6 -0,8
L5	2,8	2,8	2,8	2,8	2,8
L6	32	43	59	64,8	84,8
L7	30	34	50	50	70
L8	40	56	72	92	118
L9	24	32	40	59	59
L10	22	28	35	54	54
L11	10	16,5	22	28	33
L12	—	4,5	4,5	7,5	7,5
L13	8	7,5	13	13,2	18,2
L14	2,5	4	6	6	11
L15	3	6	5,5	10,5	5
L16	2	3	3,5	3,5	7
L17	16	19	28	28	36
L18	10	14	15	15	32
L19	—	44	52	72	72
L20	—	—	10	15	15
L21	4	2,2	3,2	3,2	3,2
L22	10	12,5	17,5	17,5	22
L23	—	—	—	—	45
L24	—	—	—	—	6
L25	—	—	—	—	38
L26	8,5	10,5	12	17	17
L27	30	33	65	57	57
L28	15	19	26	43	43
L29	3	4,5	3,5	5,5	5,5
A1	32,5	39	48,5	53,5	63
B1	32,5	39	48,5	53,5	71
F _A axial N	20	55	180	180	470
C ₀ radial N	90	220	770	770	1900
weight in kg	0,08	0,19	0,5	0,6	1,3

All dimensions in mm

Ordering Code

DM XXXX - XXX - X

}

0 = basic model
1 = with end position control (sheet "end position control")
7 = with adapter plate for PSM 0600 instead of PSM 0200
8 = with 1 and 7

model code

090
rotation angle max. 90°

180
rotation angle max. 180°

Ordering Example

you order :

DM 0050 - 090 - 1

we deliver :

Rotary Module model DM 0050
rotation angle max. 90°
with end position control

Shaft-Hub Connection with Cone Clamping

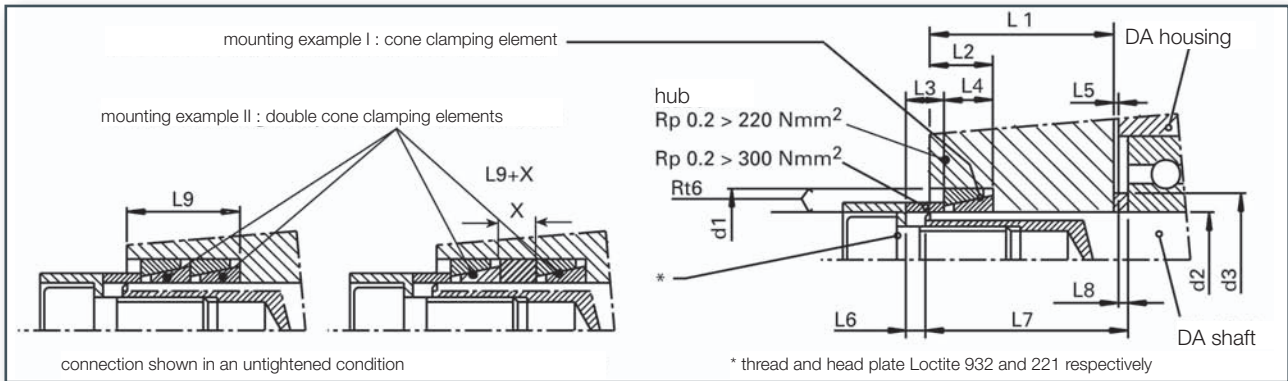

for model	DA 0050 (50 Ncm)	DAD 0050 (50 Ncm)	DA 0200 (200 Ncm)	DAD 0200 (200 Ncm)	DA 0500 (500 Ncm)	DAD 0500 (500 Ncm)
∅ d1	9 H7	9 H7	11 H7	11 H7	13 H7	13 H7
∅ d2	6 h6/H7	6 h6/H7	8 h6/H7	8 h6/H7	10 h6/H7	10 h6/H7
∅ d3	8	8	12	12	14	14
L1	ca. 8	ca. 8	ca. 14	ca. 14	ca. 19	ca. 19
L2	6	6	6	6	6	6
L3	4	4	4	4	4	4
L4	4,5	4,5	4,5	4,5	4,5	4,5
L5	>/=0,1	>/=0,1	>/=0,1	>/=0,1	>/=0,1	>/=0,1
L6	2	2	2	2	2	2
L7	9,5	9,5	15,5	15,5	20,9	20,9
L8	0,5	0,5	0,5	0,5	1,0	1,0
L9	9,5	9,5	10,5	10,5	10,5	10,5
transmittable torque mounting examples I/II	2,25/3,4 Nm	2,25/3,4 Nm	4,8/7,4 Nm	4,8/7,4 Nm	9,9/15,3 Nm	9,9/15,3 Nm
clamping screw	M3x8 DIN 912	M3x8 DIN 912	M4x12 DIN 912	M4x12 DIN 912	M5x12 DIN 912	M5x12 DIN 912
clamping moment	2,5 Nm	2,5 Nm	4,0 Nm	4,0 Nm	8,5 Nm	8,5 Nm

Ordering Example: double cone clamping elements for actuator model DA 0200

All dimensions in mm

Hub flange for HPA 0750, HPA 1500, HPA 3000 Addition : Hub flange ZAF

ZAF	0750	1500	3000
for model	HPA 0750	HPA 1500	HPA 3000
L27	11	13	16,1
L28	33,5	41	49,9
L29	22	25	30
L30	54	67	81,9
L31	25±0.01	34±0.01	37±0.01
∅ d12	34 h6	43 h6	48 h6
∅ d13 TK	50	69	74
∅ d14	60-0.1	84-0.1	89-0.1
∅ d15	6E7	8E7	8E7
∅ d16	4xM6	4xM8	4xM8

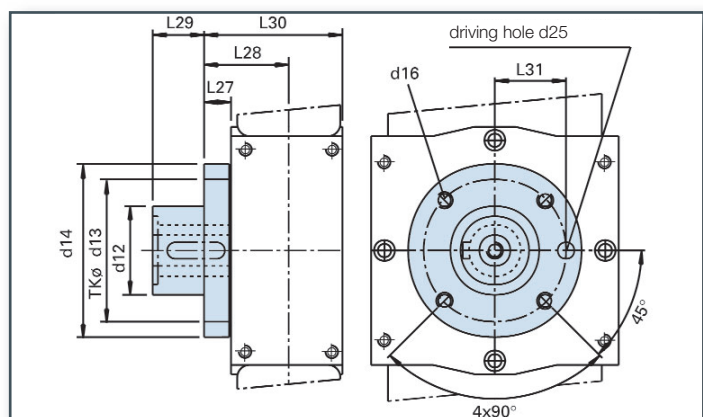

Ordering Code

ZAF XXXX

model code

Ordering Example

you order :

ZAF 1500

we deliver :

— Addition : Hub Flange for HPA 1500

Three Position Torque Cylinder

Keyword : Mid position



Actuators with an exactly defined mid position (Attention: Backlash !) are based on three piston units. The two external pistons push the piston with the rack into the mid position. If the two cylinders on both sides are without pressure and only the center piston is pressurized, the pinion will turn around the complete angle. The speciality of this construction is, that in spite of the small construction all pistons have end position damping. Field tests did prove, that this pneumatic end position damping is superior to the normally used miniature shock absorbers.

Actuators with mid position are available with torque of 50 Ncm, 200 Ncm and 500 Ncm. The standard models have rotation angles of 180° or 90°. Other angles on request.

For other details please consult the data sheets for Three Position Torque Cylinder DAD 0050, DAD 0200 and DAD 0500.

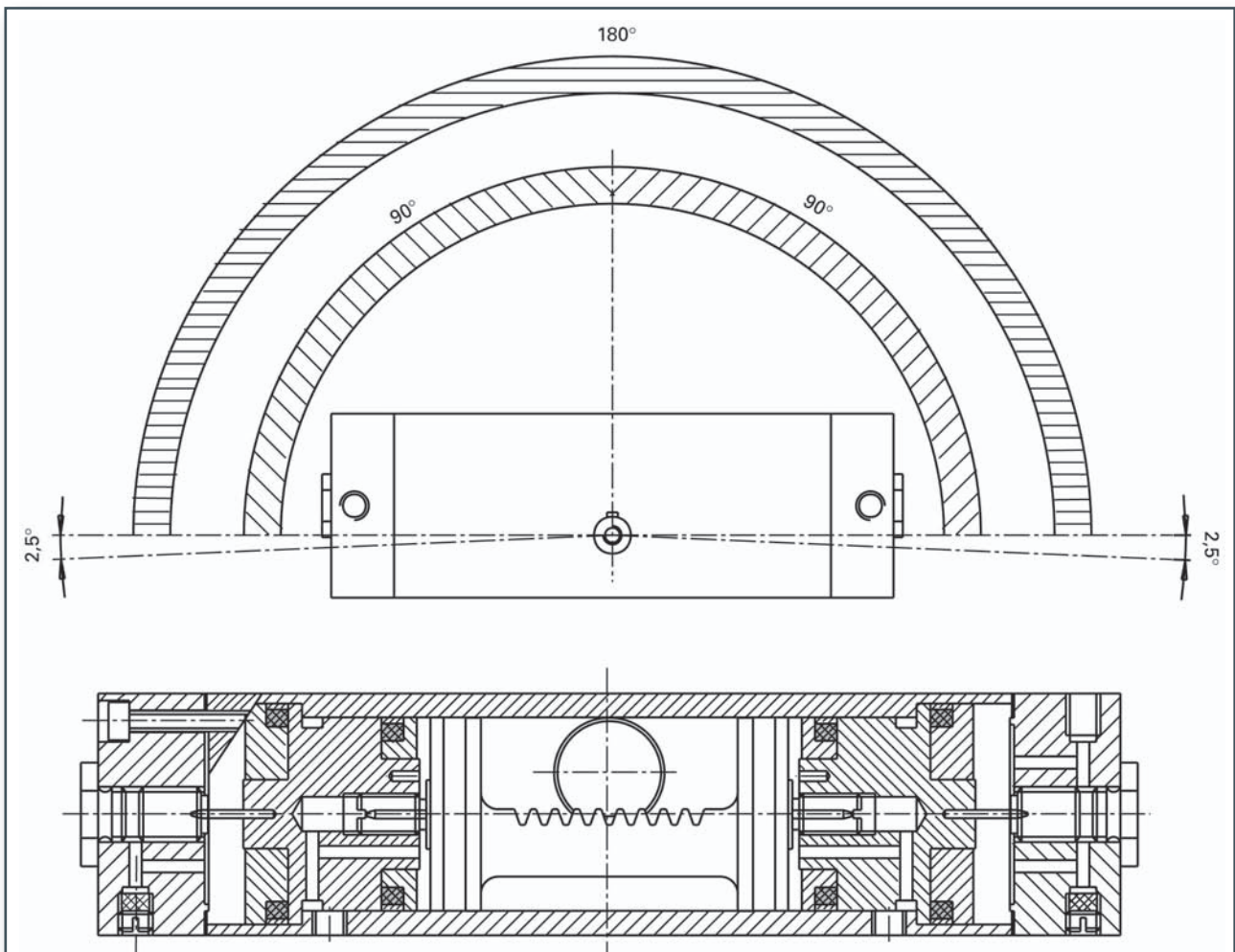

Three Position Torque Cylinder

DAD 0050, DAD 0200, DAD 0500

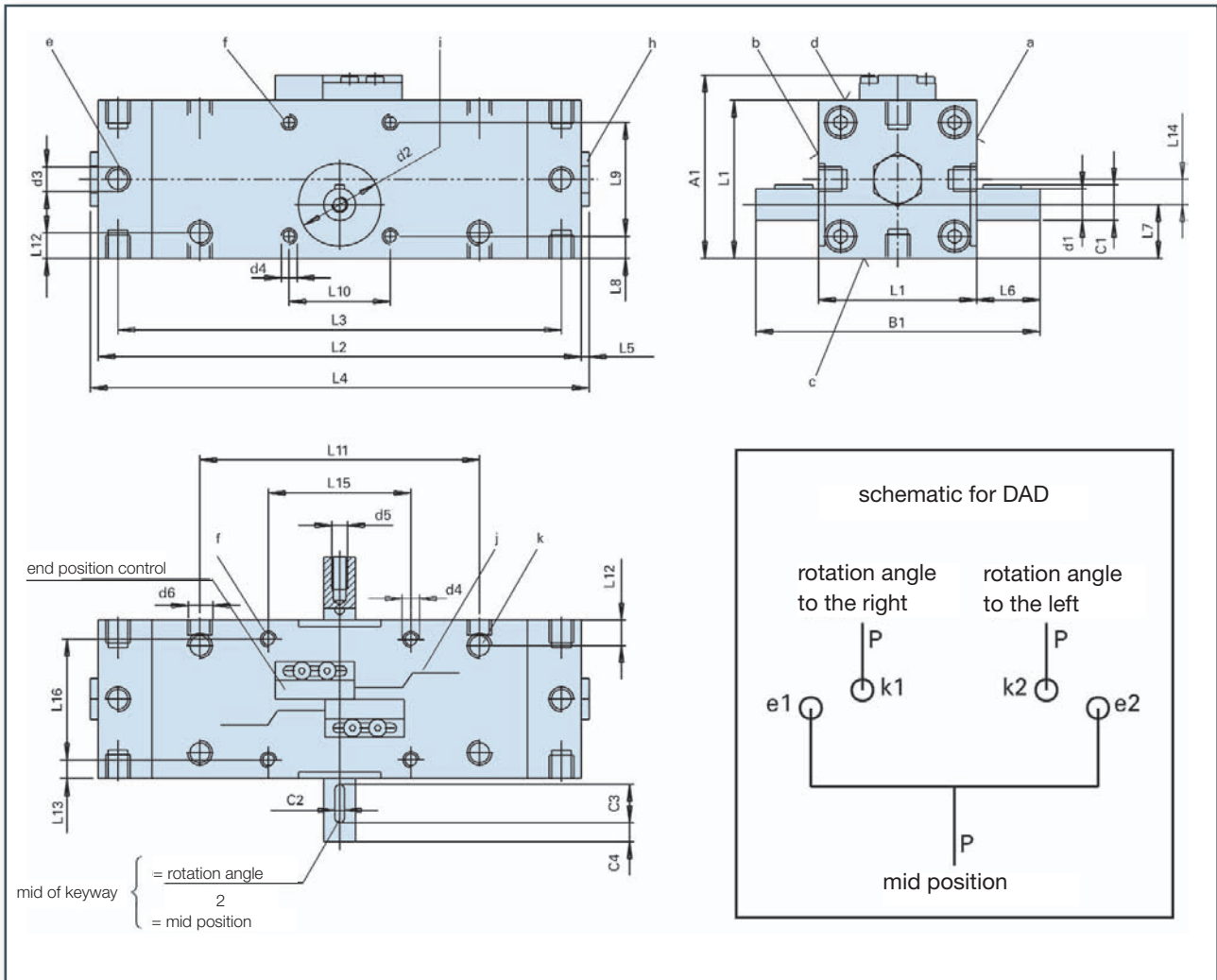

- a, b, c** mounting surface for model DAD 0050, DAD 0200
- a, b, c, d** mounting surface for model DAD 0500
- e** 4 threaded holes per head plate for air connection (mid position) and mounting alternatives
- f** 4 threaded holes for model DAD 0050 and DAD 0200 on side a and b for mounting alternatives
- f** 4 threaded holes for model DAD 0500 on side a, b, c, and d for mounting alternatives
- h** adjustment screw to limit the rotation angle (under cover screw)
- i** centre bore
- j** connection cable for end position control
- k** 2 threaded holes on side b, c, and d for air connection
- A** model with end position control
- B** model with 2 shaft ends
- C** model with keyway/key

Attention: Leave 0,4 mm (0,0157 in) for assembly insert, included in the scope of delivery.

model	DAD 0050-095	DAD 0050-185	DAD 0200-095	DAD 0200-185	DAD 0500-095	DAD 0500-185
rotation angle	95°	185°	95°	185°	95°	185°
ø d1	6 h6	6 h6	8 h6	8 h6	10 h6	10 h6
ø d2	10 J7 x0,5	10 J7 x0,5	16 J7 x0,5	16 J7 x0,5	26 J7 x0,8	26 J7 x0,8
d3	M5x4,5	M5x4,5	M5x5,5	M5x5,5	R1/8x8	R1/8x8
d4	M3x5	M3x5	M3x7	M3x7	M5x11	M5x11
d5	M3x5,5	M3x5,5	M4x9	M4x9	M5x10	M5x10
d6	M5x4	M5x4	M5x4	M5x4	R1/8x8	R1/8x8
L1	25	25	35	35	50	50
L2	105,9 ±0,5	117 ±0,5	137,5 ±0,5	156,6 ±0,5	191,6 ±0,5	225 ±0,5
L3	95,1 +0,5 -0,3	106,2 +0,5 -0,3	126,7 +0,5 -0,3	145,8 +0,5 -0,3	175,8 +0,5 -0,3	209,2 +0,5 -0,3
L4	111,5 ±0,7	122,6 ±0,7	143,1 ±0,7	162,2 ±0,7	197,2 ±0,7	230,6 ±0,7
L5	2,8	2,8	2,8	2,8	2,8	2,8
L6	9	9	15	15	20	20
L7	8,5	8,5	11,5	11,5	17	17
L8	3	3	3,5	3,5	7	7
L9	19	19	28	28	36	36
L10	14	14	15	15	32	32
L11	48,5	53,6	70,5	80,2	105,6	122,6
L12	4	4	4	4	7	7
L13	—	—	—	—	6	6
L14	—	—	—	—	11	11
L15	—	—	—	—	45	45
L16	—	—	—	—	38	38
A1	33 ±0,4	33 ±0,4	43 ±0,4	43 ±0,4	58 ±0,4	58 ±0,4
B1	43	43	65	65	89,8	89,8
C1	6,8	6,8	8,8	8,8	11,2	11,2
C2	2 N9	2 N9	2 N9	2 N9	3 N9	3 N9
C3	6	6	8	8	12	12
C4	2	2	5	5	6	6
F _A axial N	55	55	180	180	470	470
C _o radial N	220	220	770	770	1900	1900
weight in kg	0,2	0,3	0,6	0,7	1,2	1,3

Attention: end position control only possible in the end positions!

All dimensions in mm

Ordering Code

DAD 0050 - XXX - X - X

DAD 0200 - XXX - X - X

DAD 0500 - XXX - X - X

0 = basic model

1 = with end position control (sheet "end position control")

0 = 1 shaft end straight, basic model

1 = 1 shaft end with keyway/key

2 = 2 shaft ends / 1x straight, 1x keyway/key

3 = 2 shaft ends / 2x keyway/key

4 = 2 shaft ends straight

torque
at 6 bar in Ncm

rotation angle

Ordering Example

you order:
DAD 0200 - 185 - 1 - 1

we deliver:
Three Position Torque Cylinder model DAD 0200 with rotation angle 185°, end position control, 1 shaft end with keyway/key

Hydraulic-Pneumatic Rotary Actuators

HPA 0750, HPA 1500, HPA 3000

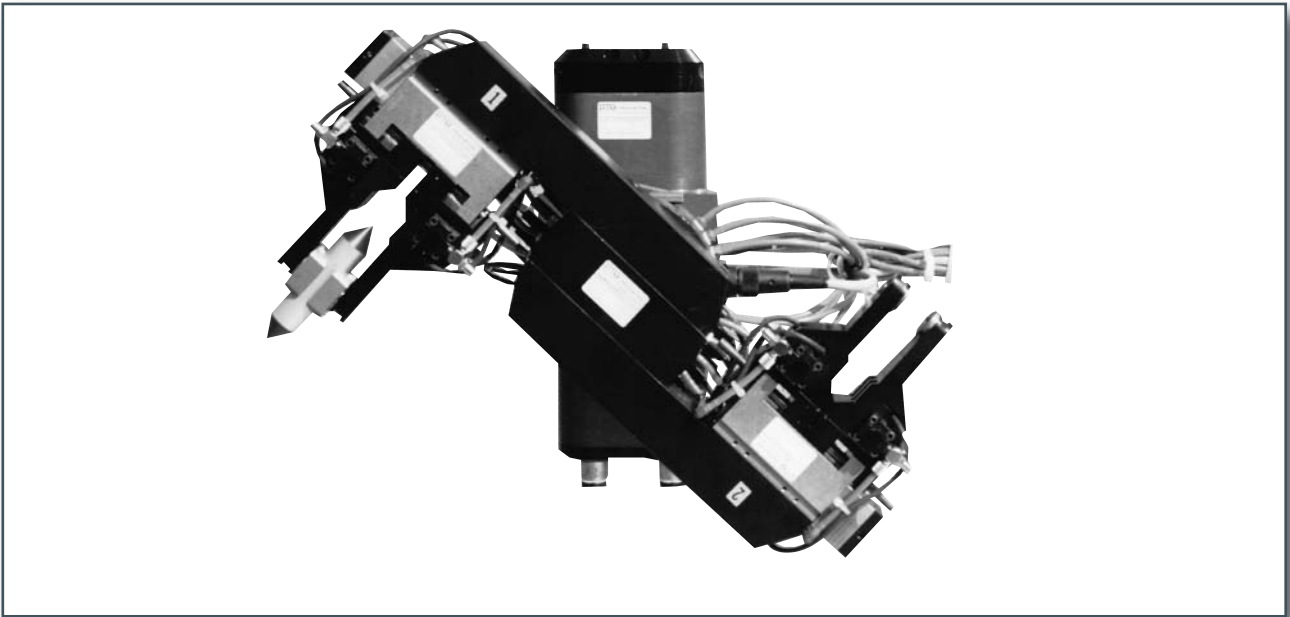

The accelerated mass represents a major problem in pneumatics. The actuator may self-destruct because of the kinetic energy. Some clients had this unpleasant experience already. Throttle valves can be used to control the rotating speed. For damping of the accelerated mass before reaching the end positions it is possible to install hydraulic shock absorbers. This will improve the situation, but the result is not totally satisfactory.

We developed the Hydraulic-Pneumatic Rotary Actuator -HPA to solve this problem. We split the task into two steps: The cheap, clean and compressible medium air will continue to do the work for the actuation. But to control the moving mass the non compressible medium oil is used in a closed hydraulic system. This allows to adjust the rotation speed exactly. A restart after an E-stop is possible without any problems. There are two independent and adjustable rotation speeds possible. This guarantees a precise and constant adjustment of the end position damping.

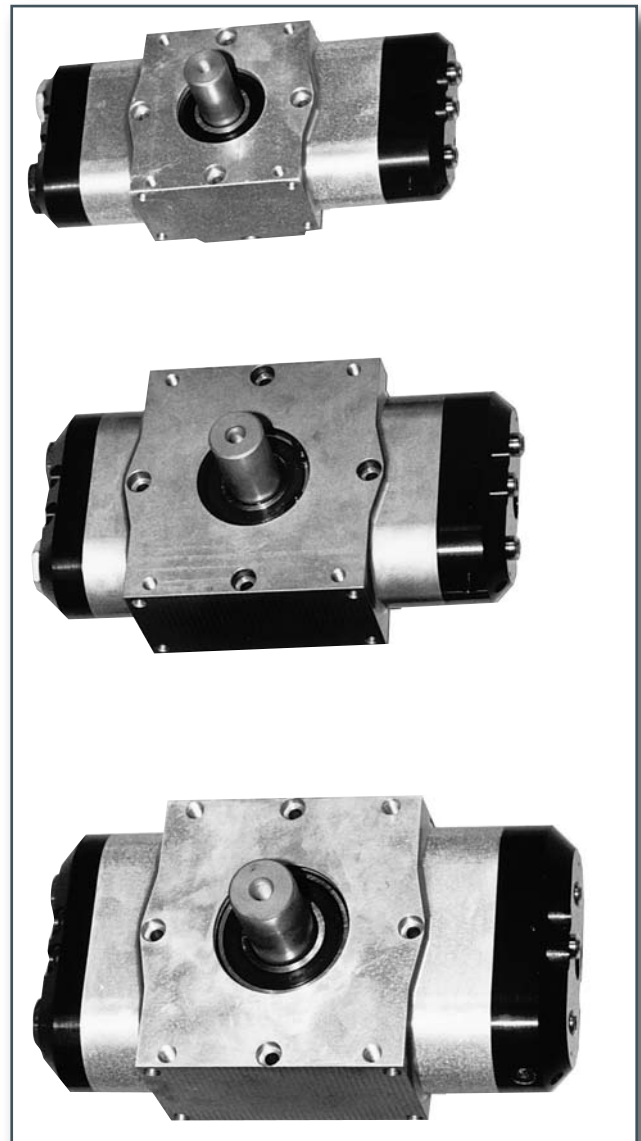

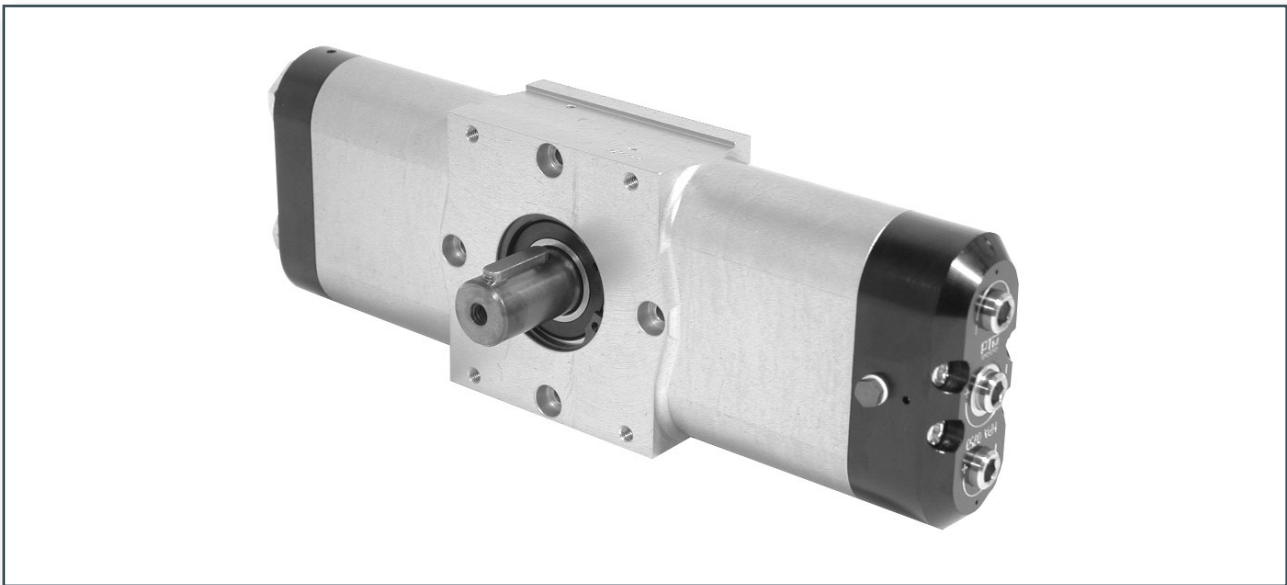

Material:	<ul style="list-style-type: none"> - aluminum hard or black anodized - steel parts of stainless material or corrosion resistant - shorttime gas nitration
Operating or mounting position:	<ul style="list-style-type: none"> - any position desired
Operating media:	<ul style="list-style-type: none"> - filtered oiled air or filtered oil-free air
Operating pressure:	<ul style="list-style-type: none"> - maximum 8 bar = 118 psi (specs are based on 6 bar = 88 psi)
Rotation speed:	<ul style="list-style-type: none"> - exactly adjustable stroke speeds are possible through a closed loop hydraulic system - no extra pipes for leakage of hydraulics necessary
Rotation time:	<ul style="list-style-type: none"> - from 0,5 sec. to several minutes at a rotation angle of 180° for example
Rotation angle:	<ul style="list-style-type: none"> - rotation angle of maximum 365°, 185° and 95° - adjustable until -15° through adjustment screws
End position damping:	<ul style="list-style-type: none"> - progressive damping characteristics - the damping distance and damping characteristics are adjustable
End position control with LED:	<ul style="list-style-type: none"> - please see our sheet "end position control" on page 44
Shaft-Hub connection:	<ul style="list-style-type: none"> - keyway/key - hub flange
Operating temperature:	<ul style="list-style-type: none"> - -10° C to +80° C (14°F to 176°F)
Maintenance:	<ul style="list-style-type: none"> - all PTM actuators are maintenance-free
Installation information:	<ul style="list-style-type: none"> - because of the hydraulic controlled movements the use of the throttle valves is not necessary

Hydraulic-Pneumatic Rotary Actuators

HPA 0750, HPA 1500, HPA 3000

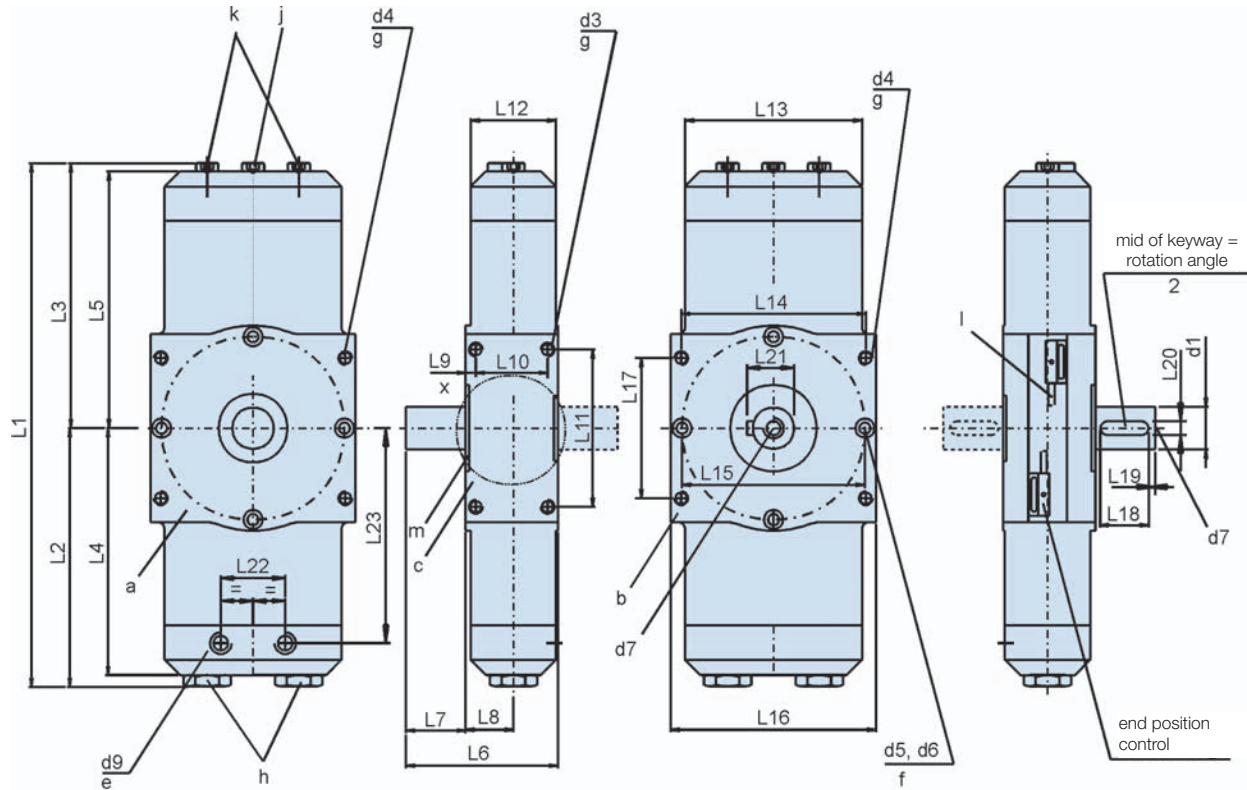

Dimensions:
Detail X

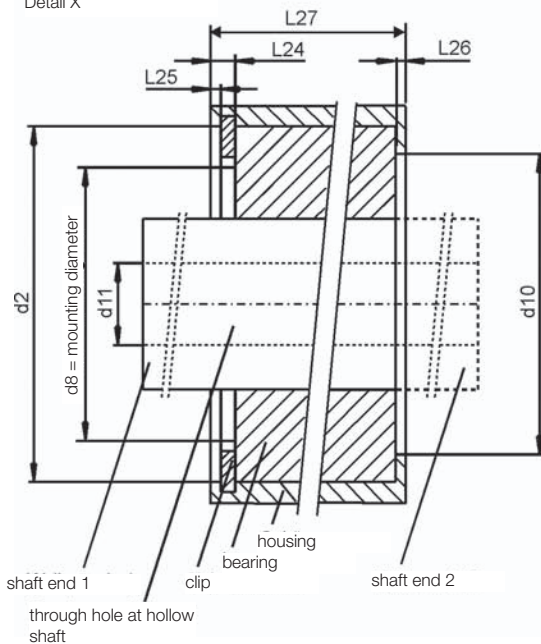

Attention: Dimensions and ordering code for HPA-hub flange you will find on page 12 of the catalog.

ADDITION : Hub flange ZAF

- a, b, c** mounting surface
- e** air connections, 2x
- f** mounting alternatives, 4x bores for mounting DIN 74 with through holes on side **a, b**
- g** mounting alternatives, 4x threaded holes on side **a, b, c**
- h** adjustment screws to limit the rotation angle until -15°
- j** adjustment screw for rotation speed
- k** adjustment screws for end position damping
- l** connection cable for end position control
- m** centre bore

Attention: Dimensions of shaft end 2 are identical with shaft end of the basic model.

model	HPA 0750			HPA 1500			HPA 3000		
	750 Ncm at 6 bar			1500 Ncm at 6 bar			3000 Ncm at 6 bar		
torque									
rotation angle	095°	185°	365°	095°	185°	365°	095°	185°	365°
L1	210,8	270,4	389,8	233,2	305,6	450,4	257,8	339,4	502,8
L2	102,8	132,6	192,3	114,1	150,3	222,7	125,8	166,6	248,3
L3	108,0	137,8	197,5	119,1	155,3	227,7	132,0	172,8	254,5
L4	95,9	125,7	185,4	107,2	143,4	215,8	118,9	159,7	241,4
L5	103,5	133,3	193,0	114,6	150,8	223,2	127,5	168,3	250,0
L6	73,0	73,0	73,0	89,0	89,0	89,0	106,0	106,0	106,0
L7	30,0	30,0	30,0	35,0	35,0	35,0	40,0	40,0	40,0
L8	22,5	22,5	22,5	28,0	28,0	28,0	34,0	34,0	34,0
L9	5,0	5,0	5,0	6,0	6,0	6,0	6,0	6,0	6,0
L10	33,0	33,0	33,0	42,0	42,0	42,0	54,0	54,0	54,0
L11	70,0	70,0	70,0	98,0	98,0	98,0	108,0	108,0	108,0
L12	39,0	39,0	39,0	50,0	50,0	50,0	62,0	62,0	62,0
L13	84,6	84,6	84,6	103,6	103,6	103,6	123,8	123,8	123,8
L14	78,0	78,0	78,0	107,0	107,0	107,0	118,0	118,0	118,0
ø L15	76,0	76,0	76,0	107,0	107,0	107,0	118,0	118,0	118,0
L16	88,0	88,0	88,0	120,0	120,0	120,0	130,0	130,0	130,0
L17	60,0	60,0	60,0	86,0	86,0	86,0	92,0	92,0	92,0
L18	25,0	25,0	25,0	28,0	28,0	28,0	36,0	36,0	36,0
L19	3,0	3,0	3,0	4,0	4,0	4,0	4,0	4,0	4,0
L20	6,0 N9	6,0 N9	6,0 N9	8,0 N9	8,0 N9	8,0 N9	8,0 N9	8,0 N9	8,0 N9
L21	22,5	22,5	22,5	28,0	28,0	28,0	33,0	33,0	33,0
L22	33,0	33,0	33,0	41,0	41,0	41,0	46,0	46,0	46,0
L23	81,4	111,2	170,9	91,0	127,0	199,0	104,0	144,8	226,5
L24	3,0	3,0	3,0	3,6	3,6	3,6	4,1	4,1	4,1
L25	1,2	1,2	1,2	1,5	1,5	1,5	2,0	2,0	2,0
L26	1,0	1,0	1,0	1,5	1,5	1,5	2,0	2,0	2,0
L27	43,0	43,0	43,0	54,0	54,0	54,0	66,0	66,0	66,0
ø d1	20,0 h6	20,0 h6	20,0 h6	25,0 h6	25,0 h6	25,0 h6	30,0 h6	30,0 h6	30,0 h6
ø d2	42,0 J7	42,0 J7	42,0 J7	52,0 J7	52,0 J7	52,0 J7	62,0 J7	62,0 J7	62,0 J7
d3	4xM5/8	4xM5/8	4xM5/8	4xM6/14	4xM6/14	4xM6/14	4xM8/15	4xM8/15	4xM8/15
d4	4xM5/8	4xM5/8	4xM5/8	4xM6/10	4xM6/10	4xM6/10	4xM8/15	4xM8/15	4xM8/15
ø d5	4x5,4	4x5,4	4x5,4	4x6,4	4x6,4	4x6,4	4x6,4	4x6,4	4x6,4
ø d6	10x5,5	10x5,5	10x5,5	11x6,5	11x6,5	11x6,5	11x6,5	11x6,5	11x6,5
d7	M6x12	M6x12	M6x12	M8x16	M8x16	M8x16	M10x18	M10x18	M10x18
ø d8 max.	30,0	30,0	30,0	40,0	40,0	40,0	50,0	50,0	50,0
d9	R1/8x8	R1/8x8	R1/8x8	R1/8x8	R1/8x8	R1/8x8	R1/4x10	R1/4x10	R1/4x10
ø d10	36,0	36,0	36,0	44,0	44,0	44,0	52,0	52,0	52,0
ø d11 max.	11,0	11,0	11,0	15,0	15,0	15,0	18,0	18,0	18,0
F _A axial N	1250	1250	1250	1750	1750	1750	5000	5000	5000
C _o radial N	5000	5000	5000	7000	7000	7000	10000	10000	10000
weight in kg	ca. 2,5	ca. 2,6	ca. 2,9	ca. 3,4	ca. 3,9	ca. 4,4	ca. 5,8	ca. 6,4	ca. 6,9
compressed air/stroke in cm ³	12,7	24,7	48,7	26,4	51,4	101,5	45,8	89,1	175,8

All dimensions in mm

Ordering Code

HPA 0750 - XXX - X - X
 HPA 1500 - XXX - X - X
 HPA 3000 - XXX - X - X

torque rotation angle
at 6 bar in Ncm

Ordering Example

you order:
HPA 1500 - 185 - 1 - 1

0 = basic model
 1 = with end position control (sheet "end position control")

1 = 1 shaft end, basic model
 2 = 1 shaft end / hollow shaft
 3 = 2 shaft ends
 4 = 2 shaft ends / hollow shaft

we deliver:
 Hydraulic-Pneumatic Rotary Actuator,
 model HPA 1500, with rotation angle 185°,
 with end position control and 1 shaft end

Hydraulic-Pneumatic Multi-Position Cylinder

HPAD 3000

Rotary Switching Drive

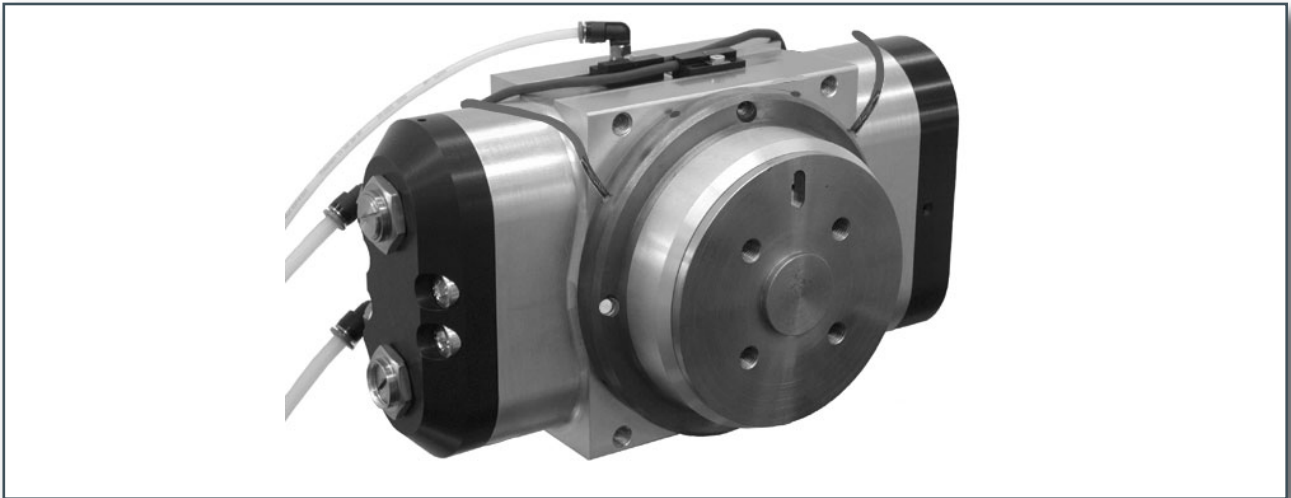

Our well-proven Hydraulic-Pneumatic Rotary Actuator HPA 3000 is an outstanding, position-precise, multi-position drive, and a rotary switching drive, which works by means of an additional structure which accepts the blocking and interlocking functions of the drive shaft. The turntable does not lift during the pivoting and switching operation, unlike traditional rotary indexing tables, therefore there is no change in the height position.

Special advantages are:

- The large torque in relation to weight and construction size.
- The torque is 3000 Ncm.
- The pivot angle steps are either 45 degrees or 90 degrees.
- All step variants (forward or back-infinite) are possible.
- The weight is only approx. 7,5 kg, and approx. 8,5 kg.
- Position precision $<0,01^\circ$
- No lifting of the switching table.
- The pivot speed is exactly adjustable.
- The adjustable pivot times extend from min. 0,5 sec. to several minutes.
- The end-position damping is progressive and adjustable.
- The drive is maintenance free.
- No functional disturbances through dirt accumulation, drive elements are encased.

ATTENTION:

- Before the pivoting of the turntable, the engaging jaw at the connection e2/P3 -> LED 1 must have compressed air applied. Vent for interlocking. For the cycle forward-switching it is necessary to run the drive back beforehand with vented engaging jaw e2/P3 -> LED 2 .

All advantages of our well known HPA design series, which have been well proven over a long time, have been taken over. (see catalog page 16-19)

Ordering Code

HPAD 3000 - XXX

Torque at 6 bar in Ncm pivot angle steps
045° / 090°

Ordering Example

You order:
HPAD 3000 - 090

We deliver:

Hydraulic-Pneumatic Multi-Position-Cylinder,
Typ HPAD 3000, with pivot angle steps 090°,
with end position control for pivoting and interlocking

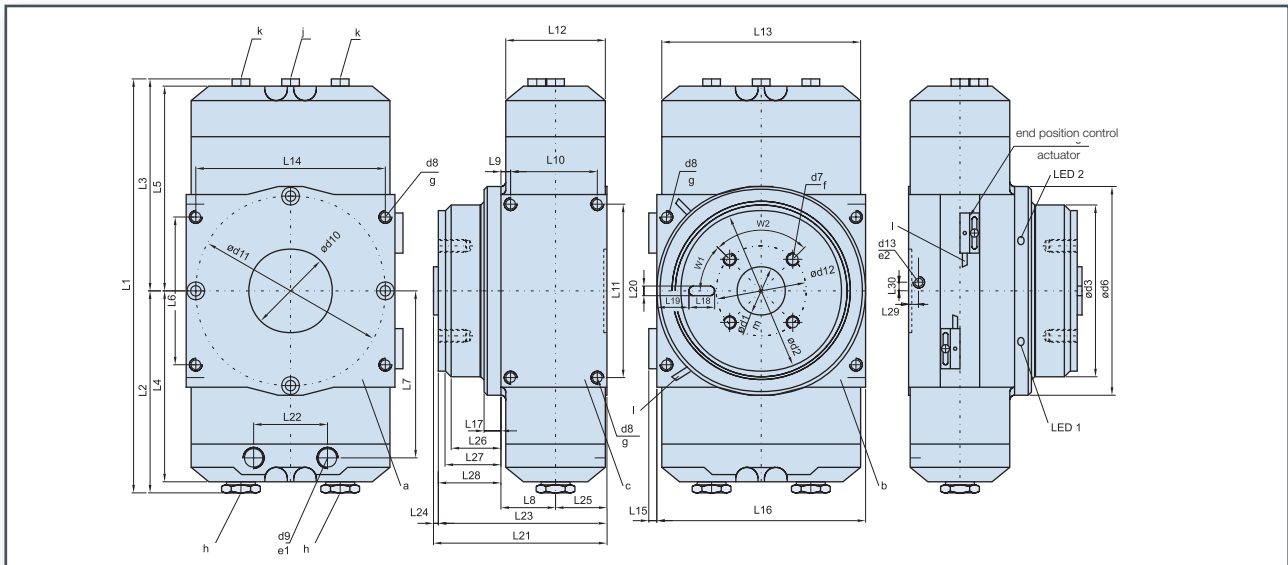

- a, b, c** mounting surfaces
- e1** air connections 2x for actuation (forward/back)
- e2** air connection 1x for engaging jaw (on/off)
- f** threaded bores for mounting 4x
- 9** mounting alternatives, 4x threaded bores on mounting surfaces **a, b, c**
- h** adjustment screws to limit the rotation angle (fixed setting)
- j** adjustment screw for rotation speed
- k** adjustment screws for end position damping
- l** connection cable for end position control
- m** centering shoulder

model		HPAD 3000			
torque		3000 Ncm at 6 bar			
rotation angle	45°-steps	90°-steps		45°-steps	90°-steps
L1	247,6	257,8	d1	∅ 30,0 h6	∅ 30,0 h6
L2	120,7	125,8	d2	∅ 100,0	∅ 100,0
L3	126,9	132,0	d3	∅ 107,0	∅ 107,0
L4	113,8	118,9	d6	∅ 130,0	∅ 130,0
L5	122,4	127,5	d7	4x M8x17	4x M8x17
L6	92,0	92,0	d8	4x M8x15	4x M8x15
L7	98,9	104,0	d9	R1/4x10	R1/4x10
L8	34,0	34,0	d10	∅ 52,0 x 2,0	∅ 52,0 x 2,0
L9	6,0	6,0	d11	∅ 118,0	∅ 118,0
L10	54,0	54,0	d12	∅ 56,0	∅ 56,0
L11	108,0	108,0	d13	M5x5	M5x5
L12	62,0	62,0			
L13	123,8	123,8	W1	45°	45°
L14	118,0	118,0	W2	4x90°	4x90°
L15	5,0	5,0			
L16	130,0	130,0			
L17	10,5	10,5			
L18	16,0	16,0			
L19	20,0	20,0			
L20	6,0 N9	6,0 N9			
L21	108,0	108,0			
L22	46,0	46,0			
L23	105,0	105,0	F _A axial N	5000	5000
L24	3,0	3,0	C _o radial N	15000	15000
L25	32,0	32,0	weight kg	ca. 7,5	ca. 8,5
L26	31,0	31,0			
L27	34,8	34,8			
L28	39,0	39,0			
L29	10,0	10,0			
L30	10,0	10,0			

LED 1 LED – signal engaging jaw ON, turntable unlocked, ready for pivoting

LED 2 LED – signal engaging jaw OFF, turntable locked

ATTENTION:

Before the pivoting of the turntable, the engaging jaw at the connection e2/P3 must have compressed air applied. Vent for interlocking.

For the cycle forward-switching it is necessary to run the drive back beforehand with vented engaging jaw e2/P3.

All dimensions in mm

Pneumatic Parallel Gripper

PSM, PSMU

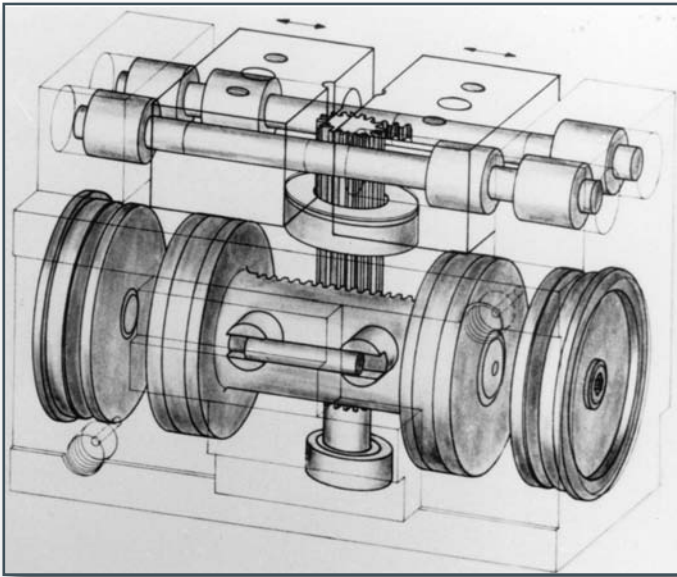

picture 2

PTM-Parallel Grippers are based on the rack-and-pinion principle like our rotating actuators. (picture 2) This fact allows for a compact design with small dimensions and low weight while still offering a high grip force.

The rack and pinion design produces an even clamping force over the whole range. The clamping jaws are absolutely centered in each position. Shortest clamping times are possible.

Each base jaw is connected tightly with one rack. This creates the great advantage that the jaws are firmly guided over the whole length of the gripper.

This long jaw guidance guarantees close tolerance, high precision and long life.

It is possible to work with very long clamping fingers without any problems.

This advantages are enhanced in the alternative -PSMU- the PTM-Parallel Gripper with u-shaped jaws.

Another option is the use of a spring in our Parallel Grippers, model ZFS, to secure the grip force during air pressure failure. With this it is possible to work only with one air connection.

Our Multi Position Cylinders -ZMZ- offer as many as two additional stops or additional strokes, which is very important in case of space restrictions.

The „Attachment for centering“ guarantees an exact exchange or a quick change position of the Parallel Gripper.

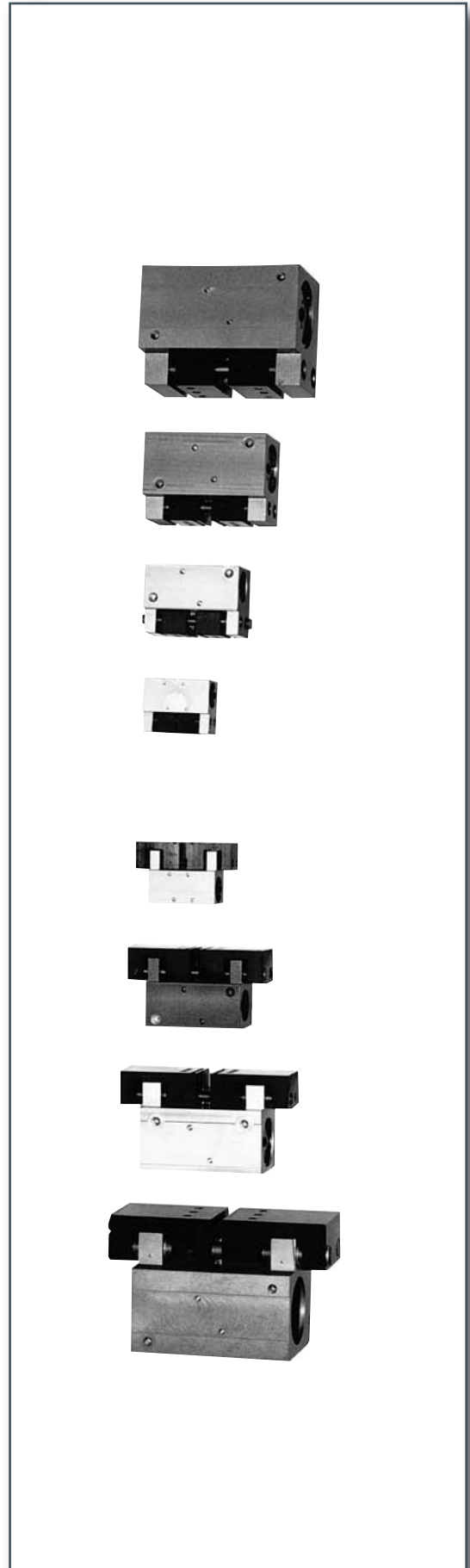

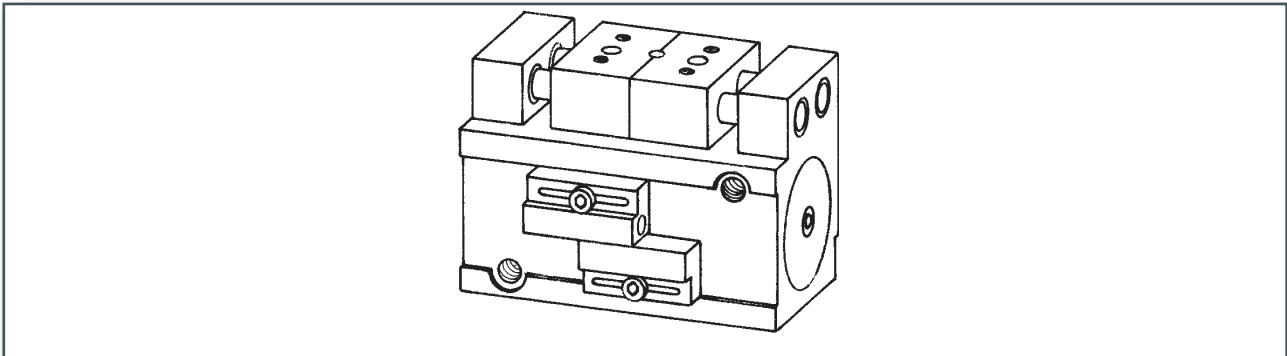

Material:	<ul style="list-style-type: none"> - aluminum hard or black anodized - steel parts of stainless material or corrosion resistant - shorttime gas nitration
Operating or mounting position:	<ul style="list-style-type: none"> - any position desired
Operating temperature:	<ul style="list-style-type: none"> - -10° to +80° C (14° to 176° F)
Operating media:	<ul style="list-style-type: none"> - filtered oiled air, or filtered oil-free air - Attention: only oil-free air should be used at low movements as interruptions could harm the smooth process.
Operating pressure:	<ul style="list-style-type: none"> - maximum 6 bar (specs are based on 6 bar = 88 psi)
Maintenance:	<ul style="list-style-type: none"> - all PSM units are maintenance-free
Base jaw guide:	<ul style="list-style-type: none"> - bronze bushings, self lubrication - each base jaw is connected tightly with one rack - therefore each jaw is guided over the whole length of the gripper - this guarantees high accuracy and long life
Clamping force:	<ul style="list-style-type: none"> - constant over the whole stroke
Jaw stroke:	<ul style="list-style-type: none"> - can be adjusted by both cylinder head plates, if necessary, with adjustment screws
Ejection:	<ul style="list-style-type: none"> - all PSM units are provided with an ejector pin with a spring, which can be mounted in the pinion, if necessary
End position control with LED:	<ul style="list-style-type: none"> - please see our sheet „end position control“ (Page 44)
Cover:	<ul style="list-style-type: none"> - possible for all PSM units with the smallest stroke
Clamping components:	<ul style="list-style-type: none"> - are generally manufactured by the customer for external or internal gripping
Installation of clamping comp:	<ul style="list-style-type: none"> - the connection between base jaw and clamping components is adjustable - for this reason each base jaw has a fitted bore, two threaded holes and a keyway (view B-B)
Installation recommendation:	<ul style="list-style-type: none"> - to ensure long life of our devices the use of throttle valves is highly recommended

Parallel Gripper PSM 0030, PSMU 0030

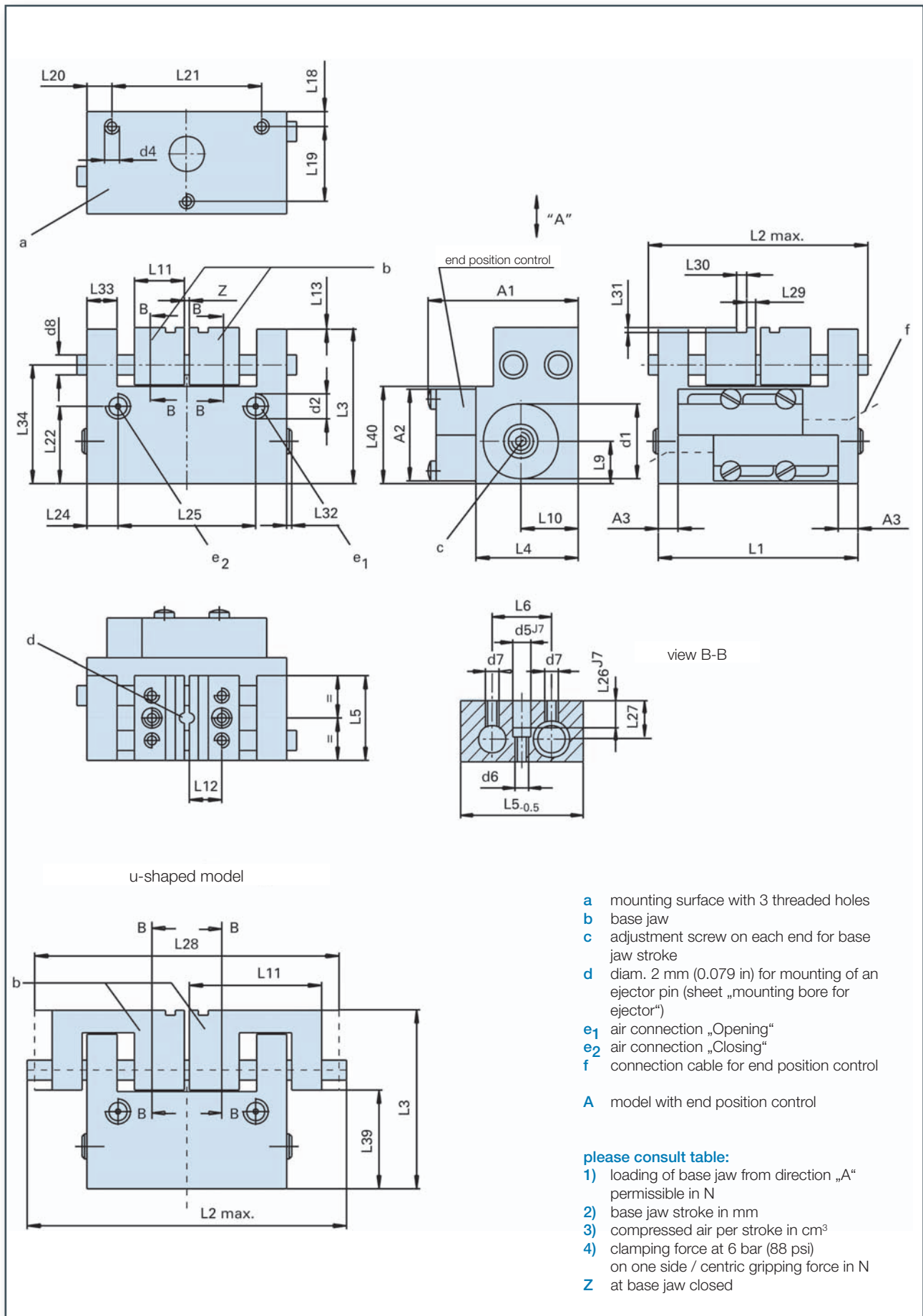

model	PSM 0030-007	PSM 0030-030	PSM 0030-052	PSMU 0030-007	PSMU 0030-030	PSMU 0030-052
ø d1	15 J7	15 J7	15 J7	15 J7	15 J7	15 J7
d2	M5x4,5	M5x4,5	M5x4,5	M5x4,5	M5x4,5	M5x4,5
d3	—	—	-	—	—	-
d4	M3x4	M3x4	M3x4	M3x4	M3x4	M3x4
ø d5	4 J7	4 J7	4 J7	4 J7	4 J7	4 J7
d6	M3x6,5	M3x6,5	M3x6,5	M3x6,5	M3x6,5	M3x6,5
d7	M3x4	M3x4	M3x4	M3x4	M3x4	M3x4
ø d8	4	4	4	4	4	4
d9	—	—	—	—	—	—
L1	40	63	98,5	40	63	98,5
max. L2	40	87	150,5	60,5	136,5	215
L3	31,3	31,3	31,3	35,8	35,8	35,8
L4	20,5	20,5	20,5	20,5	20,5	20,5
L5	17	17	17	17	17	17
L6	9	9	9	9	9	9
L9	8,5	8,5	8,5	8,5	8,5	8,5
L10	11,5	11,5	11,5	11,5	11,5	11,5
L11	10	10	10	26,5	38	49
L12	6,5	6,5	6,5	6,5	6,5	6,5
L13	0,3	0,3	0,3	—	—	—
L18	3	3	3	3	3	3
L19	15	15	15	15	15	15
L20	5	5	4,5	5	5	4,5
L21	30	53	89,9	30	53	89,9
L22	15,5	15,5	15,5	15,5	15,5	15,5
L23	—	—	—	—	—	—
L24	6,2	6,2	11,9	6,2	6,2	11,9
L25	27,6	50,6	74,7	27,6	50,6	74,7
L26	4	4	4	4	4	4
L27	5	5	5	5	5	5
L28	—	—	—	60,5	106,5	163,5
L29	1,8	1,8	1,8	1,8	1,8	1,8
L30	2 F9	2 F9	2 F9	2 F9	2 F9	2 F9
L31	1	1	1	1	1	1
L32	1	1	—	1	1	—
L33	6	6	6	6	6	6
L34	23,8	23,8	23,8	23,8	23,8	23,8
L39	—	—	-	19,8	19,8	19,8
L40	19,5	19,5	19,5	19,5	19,5	19,5
A1	30	30	30	30	30	30
A2	18,4	18,4	18,4	18,4	18,4	18,4
A3 min.	3	8	20	3	8	20
1)	65	50	50	90	75	75
2)	2x3,5	2x15	2x26	2x3,5	2x15	2x26
3)	0,6	2,6	5,0	0,6	2,6	5,0
4)	60/30	60/30	60/30	60/30	60/30	60/30
weight in kg	0,065	0,09	0,12	0,09	0,13	0,17
Z	0,5	0,5	13,5	0,5	0,5	13,5

All dimensions in mm

Ordering Code

PSM **XXXX** - **XXX** - **XXX** - **X**

0 = basic model
 — 1 = with end position control
 (sheet "end position control")

model code

base jaw stroke
in mm

clamping force
in N

Ordering Example

you order :
PSM 0030 - 030 - 060 - 1

we deliver :
 Parallel Gripper PSM 0030
 base jaw stroke 30 mm,
 — clamping force 60 N,
 with end position control

Parallel Gripper PSM 0050, PSM 0200, PSM 0600

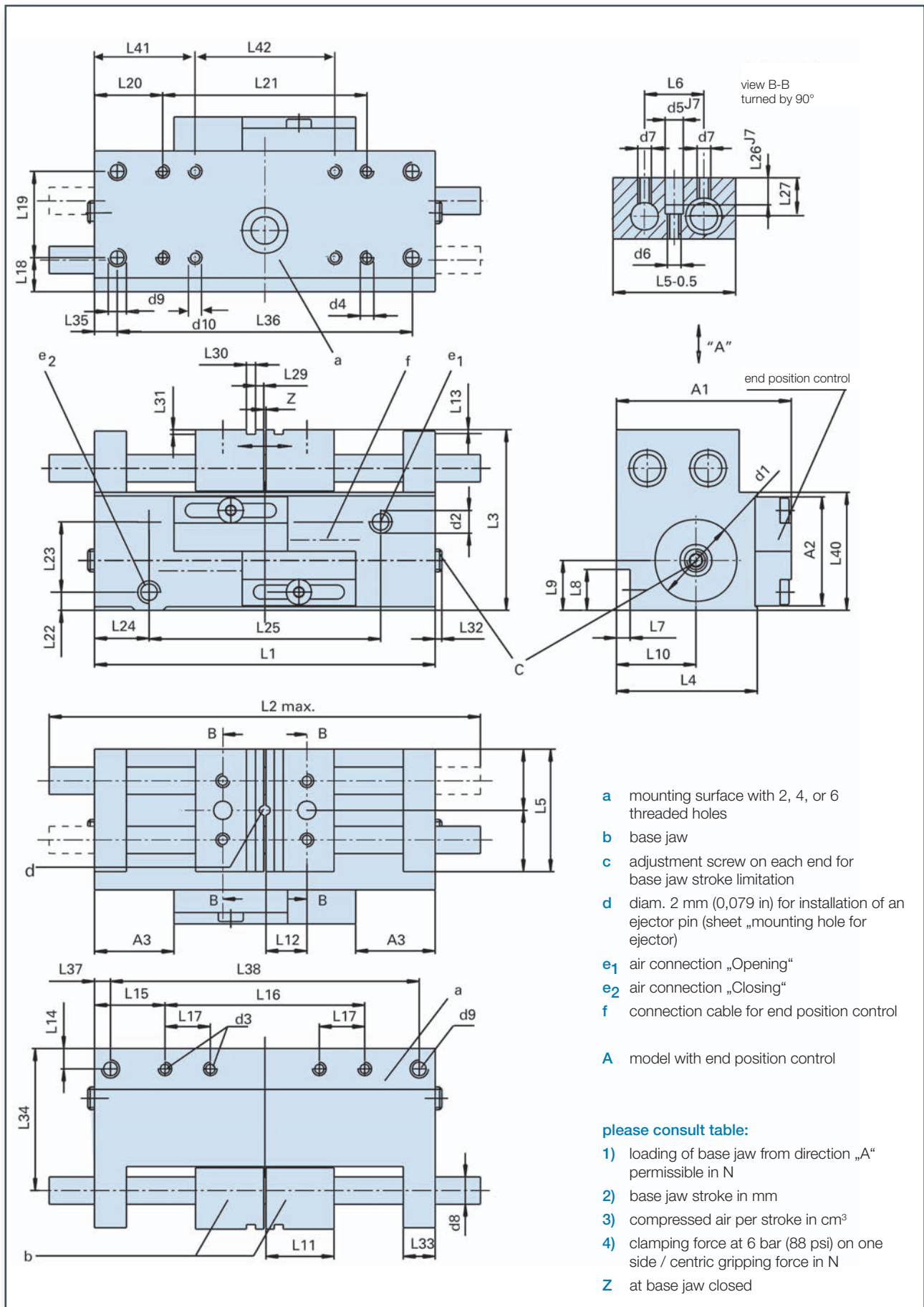

PSM	0050-011	0050-029	0050-052	0200-013	0200-027	0200-052	0200-105	0600-016	0600-030	0600-060
ø d1	18 J7	18 J7	18 J7	28 J7	28 J7	28 J7	28 J7	38 J7	38 J7	38 J7
d2	M5x4,5	M5x4	M5x4	M5x4,5	M5x4,5	M5x4,5	M5x4,5	M5x5	M5x5	M5x5
d3	M3x5,5	M3x5,5	M3x5,5	M3x5	M3x5	M3x5	M3x5	M4x8	M4x8	M4x8
d4	M3x5,5	M3x4	M3x4	M3x5,5	M3x5	M3x5	M3x5	M4x8	M4x8	M4x8
ø d5	4 J7	4 J7	4 J7	4 J7	4 J7	4 J7	4 J7	5 J7	5 J7	5 J7
d6	M3x5,5	M3x5,5	M3x5,5	M3x5,5	M3x5,5	M3x9,5	M3x9,5	M4x6	M4x6	M4x6
d7	M3x4	M3x4	M3x4	M3x4	M3x4	M4x5,5	M4x5,5	M4x4	M4x4	M4x4
ø d8	6	6	6	6	6	8	8	10	10	10
d9	—	—	—	—	M4x5,5	M4x7	M4x7	—	—	—
d10	—	—	—	M4x5	—	—	—	M5x10	M5x10	M5x10
L1	56	75	135	72	86	138	219	92	106	156
L2 max.	65,5	103	160	74,5	105,5	172	302,5	96	128	186
L3	39,8	39,8	39,8	49,8	49,8	54	54	66,5	66,5	66,5
L4	31	31	31	37,5	37,5	37,5	37,5	59	59	59
L5	27	27	27	30	30	30	30	44,2	44,2	44,2
L6	13	13	13	13	13	15	15	26,1	26,1	26,1
L7	3	3	3	3	3	3	3	5	5	5
L8	9	9	9	9	9	9	9	15	15	15
L9	11	11	11	16	16	16	16	24	21	24
L10	17,5	17,5	17,5	19	19	19	19	35	35	35
L11	15	15	20	18	18	18	18	23	23	23
L12	9	9	10	10	10	10	10	16	16	16
L13	0,3	0,3	0,3	0,3	0,3	0,3	0,3	0,5	0,5	0,5
L14	4,5	4,5	4,5	4,5	4,5	4,5	4,5	7,5	7,5	7,5
L15	6	3,5	33,5	10	17	43	83,5	10	17	42
L16	44	68	68	52	52	52	52	72	72	72
L17	—	12	12	10	10	10	10	15	15	15
L18	7,5	7,5	7,5	6,5	6,5	6,5	6,5	10,5	10,5	10,5
L19	19	19	19	26	26	26	26	43	43	43
L20	11,5	7	17,5	3,5	10,5	36,5	77	17,5	24,5	20
L21	33	61	100	65	65	65	65	57	57	116
L22	4,5	4,5	4,5	4,5	4,5	4,5	4,5	7,5	4,5	7,5
L23	15	15	15	23,5	23,5	23,5	23,5	33	33	33
L24	6	12	29	10	15	28	42,5	10	13	13
L25	44	51	77	52	56	82	134	72	80	130
L26	6	6	6	6	6	6	6	10	10	10
L27	8	8	8	8	8	8	8	12	12	12
L29	1,8	1,8	1,8	1,8	1,8	1,8	1,8	1,8	1,8	1,8
L30	2 F9	2 F9	2 F9	2 F9	2 F9	2 F9	2 F9	3 F9	3 F9	3 F9
L31	1	1	1	1	1	1	1	1,5	1,5	1,5
L32	1,7	—	—	—	—	—	—	—	—	—
L33	7	7	21	11	11	24,5	24,5	14,5	14,5	24,5
L34	31,3	31,3	31,3	41,3	41,3	42,8	42,8	55,5	55,5	55,5
L35	—	—	—	—	3,5	6	6	—	—	—
L36	—	—	—	—	79	126	207	—	—	—
L37	—	—	—	—	—	12	12	—	—	—
L38	—	—	—	—	—	114	195	—	—	—
L40	26	26	26	36	36	36	36	48	48	48
L41	—	—	—	15,5	—	—	—	32,5	39,5	30
L42	—	—	—	41	—	—	—	27,0	27,0	96,0
A 1	38,5	38,5	38,5	45	45	45	45	66,5	66,5	66,5
A 2	24	24	24	24	24	24	24	24	24	24
A 3	2 min.	10 min.	31 min.	9 min.	17 min.	32 min.	57 min.	18 min.	23 min.	45 min.
1)	100	75	50	100	75	150	200	500	300	200
2)	2x5,5	2x14,5	2x26	2x6,5	2x13,5	2x26	2x52,5	2x8	2x15	2x30
3)	1,4	3,7	6,6	4,0	8,3	16,0	39,7	9,1	17,0	34,0
4)	100/50	100/50	100/50	250/125	250/125	250/125	250/125	500/250	500/250	500/250
weight kg	0,18	0,23	0,39	0,31	0,35	0,55	0,89	0,91	1,0	1,4
Z	0,5	0,5	0,5	0,5	0,5	0,5	28,5	0,5	0,5	0,5

All dimensions in mm

Ordering Code

PSM XXXX - XXX - XXX - X

|
|
|
|
|
|
|
|
|
|
|

model code
base jaw stroke in mm
clamping force in N

Ordering Example you order : **PSM 0200 - 013 - 250 - 1**

0 = basic model
1 = with end position control
5 = with cover only for:
6 = with 1 and 5 PSM0050-011-100
 PSM0200-013-250
 PSM0600-016-500

we deliver :
 Parallel Gripper model PSM 0200,
 with base jaw stroke 13 mm,
 clamping force 250 N, with end pos. control

Parallel Gripper PSMU 0050, PSMU 0200, PSMU 0600

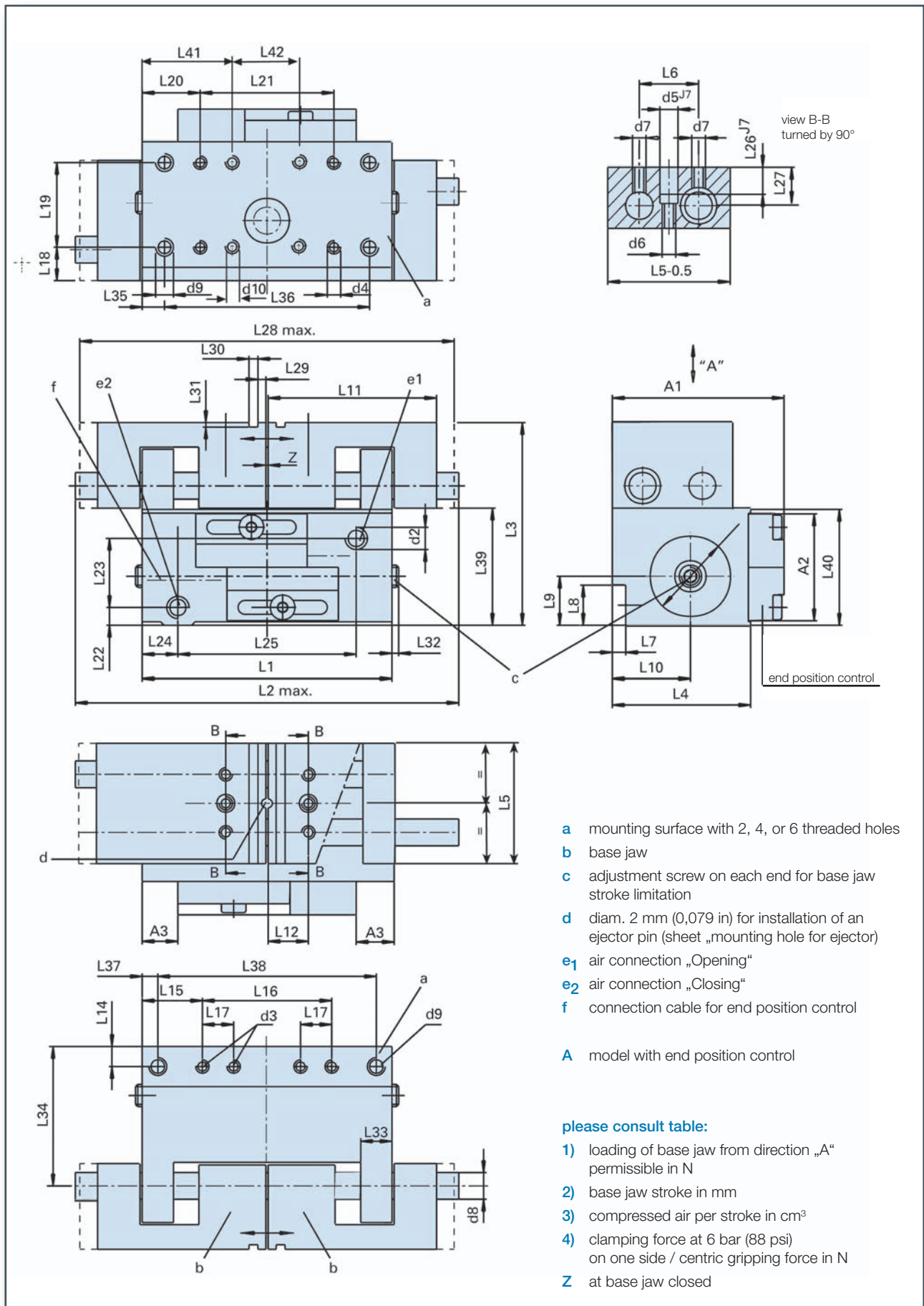

PSMU	0050-011	0050-029	0050-052	0200-013	0200-027	0200-052	0200-105	0600-016	0600-030	0600-060
ø d1	18 J7	18 J7	18 J7	28 J7	28 J7	28 J7	28 J7	38 J7	38 J7	38 J7
d2	M5x4,5	M5x4	M5x4	M5x4,5	M5x4,5	M5x4,5	M5x4,5	M5x5	M5x5	M5x5
d3	M3x5,5	M3x5,5	M3x5,5	M3x5	M3x5	M3x5	M3x5	M4x8	M4x8	M4x8
d4	M3x5,5	M3x4	M3x4	M3x5,5	M3x5	M3x5	M3x5	M4x8	M4x8	M4x8
ø d5	4 J7	4 J7	4 J7	4 J7	4 J7	4 J7	4 J7	5 J7	5 J7	5 J7
d6	M3x11	M3x11	M3x11	M3x11	M3x11	M3x16	M3x5	M4x14	M4x14	M4x14
d7	M4x10	M4x10	M4x10	M4x10	M4x10	M4x12,5	M4x10	M5x13	M5x13	M5x13
ø d8	6	6	6	6	6	8	8	10	10	10
d9	—	—	—	—	M4x5,5	M4x7	M4x7	—	—	—
d10	—	—	—	M4x5	—	—	—	M5x10	M5x10	M5x10
L1	56	75	135	72	86	138	219	92	106	156
L2	86,5	144,5	254	106,5	150,5	258	442,5	137	185	296
L3	45,3	45,3	45,3	55,3	55,3	62	64	74,5	74,5	74,5
L4	31	31	31	37,5	37,5	37,5	37,5	59	59	59
L5	27	27	27	30	30	30	30	44,2	44,2	44,2
L6	13	13	13	13	13	13	13	26,1	26,1	26,1
L7	3	3	3	3	3	3	3	5	5	5
L8	9	9	9	9	9	9	9	15	15	15
L9	11	11	11	16	16	16	16	24	21	24
L10	17,5	17,5	17,5	19	19	19	19	35	35	35
L11	38	47,5	78	46	53,5	82	108,5	60,5	67,5	92,5
L12	9	9	10	10	10	10	10	16	16	16
L14	4,5	4,5	4,5	4,5	4,5	4,5	4,5	7,5	7,5	7,5
L15	6	3,5	33,5	10	17	43	83,5	10	17	42
L16	44	68	68	52	52	52	52	72	72	72
L17	—	12	12	10	10	10	10	15	15	15
L18	7,5	7,5	7,5	6,5	6,5	6,5	6,5	10,5	10,5	10,5
L19	19	19	19	26	26	26	26	43	43	43
L20	11,5	7	17,5	3,5	10,5	36,5	77	17,5	24,5	20
L21	33	61	100	65	65	65	65	57	57	116
L22	4,5	4,5	4,5	4,5	4,5	4,5	4,5	7,5	4,5	7,5
L23	15	15	15	23,5	23,5	23,5	23,5	33	33	33
L24	6	12	29	10	15	28	42,5	10	13	13
L25	44	51	77	52	56	82	134	72	80	130
L26	6	6	6	6	6	6	6	10	10	10
L27	8	8	8	8	8	8	8	12	12	12
L28	87,5	124,5	208,5	105,5	134,5	216,5	350,5	137,5	165,5	245,5
L29	1,8	1,8	1,8	1,8	1,8	1,8	1,8	1,8	1,8	1,8
L30	2 F9	2 F9	2 F9	2 F9	2 F9	2 F9	2 F9	3 F9	3 F9	3 F9
L31	1	1	1	1	1	1	1	1,5	1,5	1,5
L32	1,7	—	—	—	—	—	—	—	—	—
L33	7	7	21	11	11	24,5	24,5	14,5	14,5	24,5
L34	31,3	31,3	31,3	41,3	41,3	42,8	42,8	55,5	55,5	55,5
L35	—	—	—	—	3,5	6	6	—	—	—
L36	—	—	—	—	79	126	207	—	—	—
L37	—	—	—	—	—	12	12	—	—	—
L38	—	—	—	—	—	114	195	—	—	—
L39	26,3	26,3	26,3	36,3	36,3	36,3	36,3	48,5	48,5	48,5
L40	26	26	26	36	36	36	36	48	48	48
L41	—	—	—	15,5	—	—	—	32,5	39,5	30,0
L42	—	—	—	41	—	—	—	27,0	27,0	96,0
A1	38,5	38,5	38,5	45	45	45	45	66,5	66,5	66,5
A2	24	24	24	24	24	24	24	24	24	24
A3 min.	2	10	31	9	17	32	57	18	23	45
1)	150	110	75	150	110	225	300	750	450	300
2)	2x5,5	2x14,5	2x26	2x6,5	2x13,5	2x26	2x52,5	2x8	2x15	2x30
3)	1,4	3,7	6,6	4,0	8,3	16,0	39,7	9,1	17,0	34,0
4)	100/50	100/50	100/50	250/125	250/125	250/125	250/125	500/250	500/250	500/250
weight kg	0,24	0,30	0,48	0,45	0,5	0,75	1,16	1,13	1,2	1,6
Z				0,5			28,5		0,5	

All dimensions in mm

Ordering Code

PSMU XXXX - XXX - XXX - X

|
|
|

model code
base jaw stroke in mm
clamping force in N

Ordering Example you order : PSMU 0200 - 013 - 250 - 1

— 0 = basic model
 1 = with end position control (sheet end pos. control)

we deliver :
 Parallel Gripper with u-shaped jaws,
 model PSMU 0200,
 — with base jaw stroke 13 mm,
 clamping force 250 N, with end pos. control

Parallel Gripper PSMU 1200, PSMU 3000

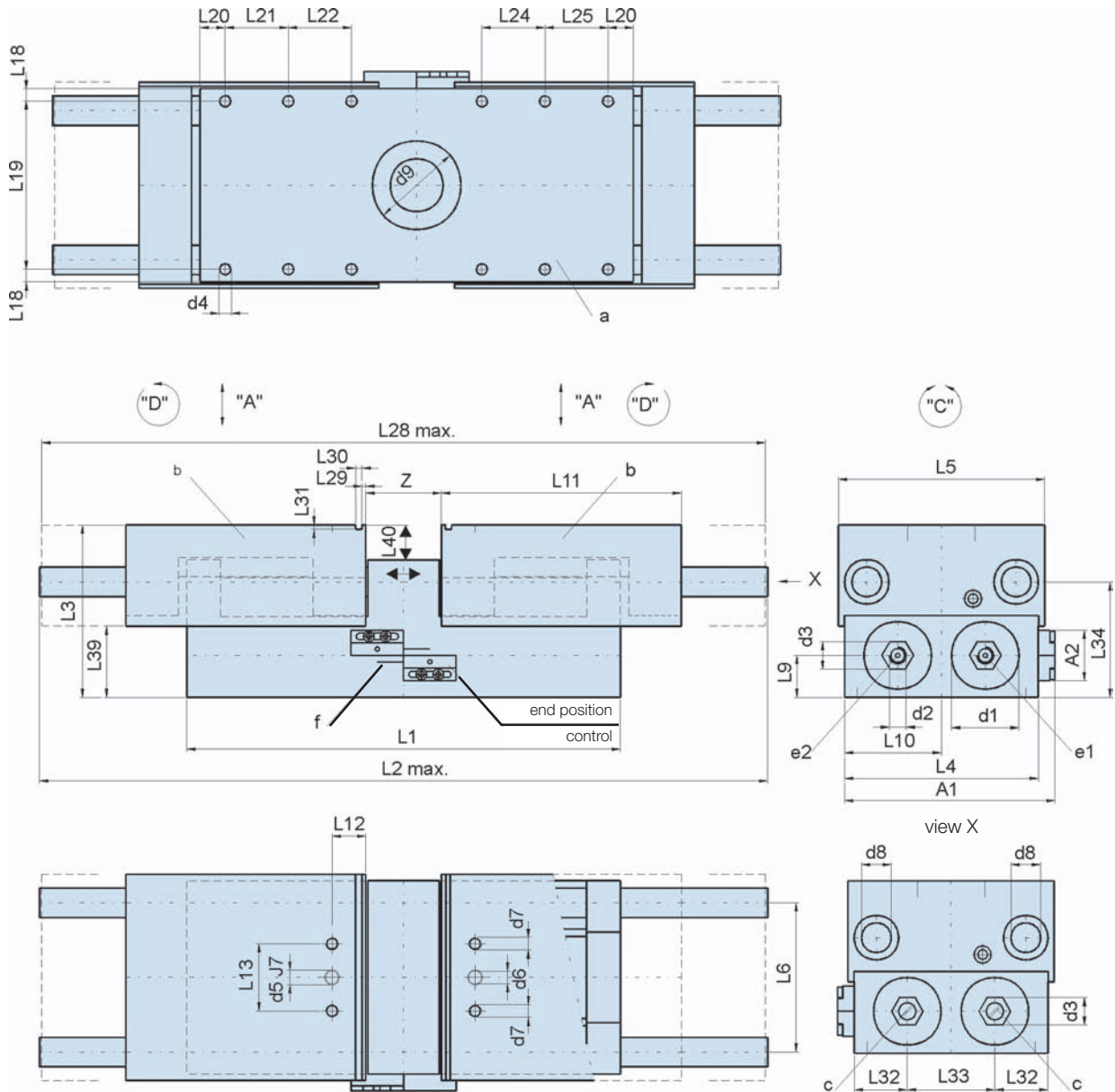

- a** mounting surface with 12 threaded holes
- b** base jaw
- c** adjustment screws, for base jaw stroke limitation
- e₁** air connection „Opening“
- e₂** air connection „Closing“
- f** connection cable for end position control

- A** model with end position control

model	PSMU 1200-080	PSMU 3000-080
ø d1	33.0	53.0
d2	R1/8x8	R1/4x10
d3	6kt SW13	6kt SW 19
d4	M6x12	M8x12
ø d5	6.0 J7 x12	8.0 J7 x20
d6	M5x10	M6x10
d7	M6x18	M8x20
ø d8	14.0	20.0
ø d9	42.0x1.0	62.0
L1	243.0	318.0
max. L2	384.0	464.0
L3	82.0	125.0
L4	92.0	134.0
L5	98.0	141.0
L6	71.0	100.0
L9	20.0	37.6
L10	46.0	67.0
L11	114.0	122.0
L12	44.0	25.0
L13	32.0	46.0
L18	6.0	8.0
L19	80.0	118.0
L20	12.0	15.0
L21	30.0	50.0
L22	30.0	50.0
L24	30.0	50.0
L25	30.0	50.0
max. L28	381.0	460.0
L29	29.8	10.8
L30	3.0 F9	4.0 F9
L31	1.5	1.8
L32	25.2	36.1
L33	41.6	61.8
L34	55.0	105.0
L39	34.0	61.5
L40	16,5	20,0
A1	100.0	146.0
A2	24.0	24.0
Z at base jaw closed	73.0	136.0
base jaw stroke in mm	2 x 40.0	2 x 40.0
compressed air per stroke in cm ³	100.9	319.2
clamping force at 6bar (88psi) on one side/centric gripping force in N	1200/600	3000/1500
weight in kg	4.9	ca. 5.4
loading of base jaw from direction "A"	2x 2000 N	2x 3000 N
torque Md "C"	2x 150 Nm	2x 310 Nm
torque "D"	2x 180 Nm	2x 290 Nm

All dimensions in mm

Ordering Code

PSMU XXXX - XXX - XXXX - X

model code base jaw stroke in mm clamping force in N

— 0 = basic model
— 1 = with end position control (sheet end position control)

Ordering Example

you order :

PSMU 1200 - 080 - 1200 - 1

we deliver :

Parallel Gripper with u-shaped jaws, model PSMU 1200, with base jaw stroke 80 mm, clamping force 1200 N, with end position control

Clamping modules

Three-Pivot-Finger Gripper

Dimensions

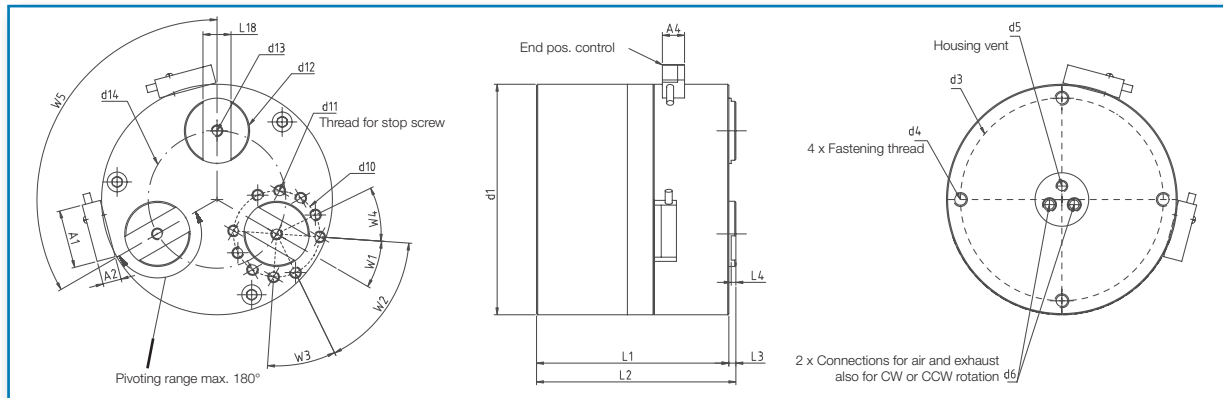

with mounting flange

with installation bracket

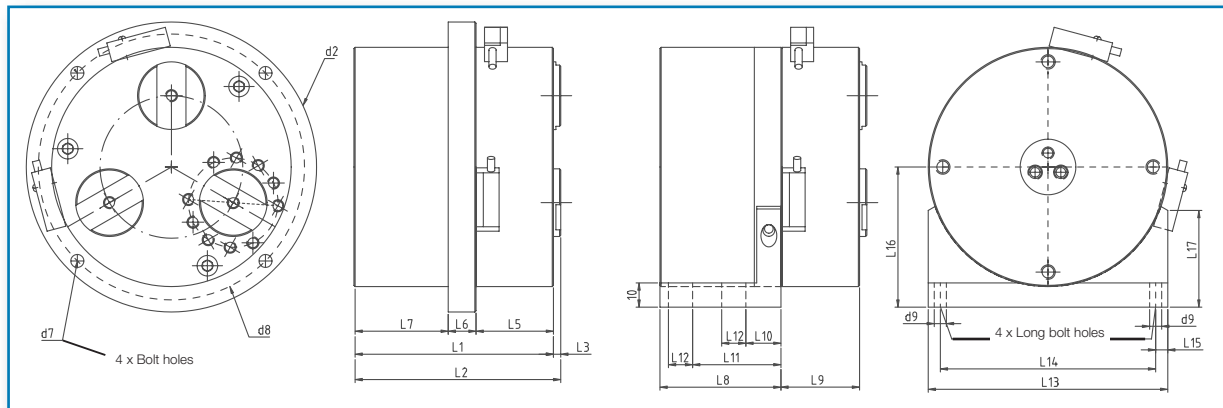

The Three-Pivot-Finger Gripper

The pivot fingers are arranged 120° apart and execute rotational movements up to a max. of 180°. Extremely large clamping strokes can be traversed with the corresponding length of clamping jaws.

The clamping jaws can be changed over with just a few hand movements!

If a user clamps geometrically similar, differently dimensioned workpieces, the large clamping strokes often mean there is no need to change over the clamping jaws and this in turn saves tooling time.

To clamp deformation-sensitive parts, the clamping force can be applied very delicately.

The large clamping stroke is easy to limit using fixed stops.

Features

- The three-pivot-finger gripper comes in 12 different types and a host of variants.
- The clamping finger torques range from 6.5 Nm to 585 Nm.

- The device can be supplied with EX Certificate 94/9/EC (on request), electronic end position control, mounting flange, installation bracket and various external seals.
- Powered by 4 different pneumatic motors and various gears.

Advantages

- High repeat accuracy!
- Very broad clamping ranges!
- Extra high clamping forces!
- The clamping forces can be applied extremely delicately for deformation-sensitive workpieces!
- Short tooling times!
- Drive with pneumatic motor!
- Housing from hard-coated aluminum!
- Minimum air consumption!
- Drives are maintenance-free and spray-water protected!

Dimensions without gear

	L 1	L 2	L 3	L 4	L 5	L 6	L 7	L 8	L 9	L 10	L 11	L 12	L 13	L 14	L 15	L 16	L 17	L 18
DSG 0450	82,5	85,5	3	2	32	11,5	39	50	32,5	14,5	36,5	10	99	89	5	58	40	12 H 7
DSG 0900	97	100	3	2	32	11,5	53,5	50	32,5	14,5	36,5	10	99	89	5	58	40	12 H 7
DSG 1800	116	120	4	3	48,5	12,5	55	67	49	16	48	15	159	140	9,5	90	55	20 F 8
DSG 3600	138	142	4	3	48,5	12,5	77	67	49	16	48	15	159	140	9,5	90	55	20 F 8

	d 1	d 2	d 3	d 4	d 5	d 6	d 7	d 8	d 9	d 10	d 11
DSG 0450	99	120	87	M 6x14	M 5x5	M 6x0,75x8	5,4	110	5	37	M 5x7
DSG 0900	99	120	87	M 6x14	M 5x5	M 6x0,75x8	5,4	110	5	37	M 5x7
DSG 1800	159	199	140	M 8x18	M 5x5	R1/8x9	8,5	180	7	56	M 8x8
DSG 3600	159	199	140	M 8x18	M 5x5	R1/8x9	8,5	180	7	56	M 8x8

	d 12	d 13	d 14	W 1	W 2	W 3	W 4	W 5	A 1	A 2	A 4
DSG 0450	28	M 5x12	59	26°	60°	4x30°	4x30°	120°	25	8	9,5
DSG 0900	28	M 5x12	59	26°	60°	4x30°	4x30°	120°	25	8	9,5
DSG 1800	42	M 8x17	93	30°	36°	-	9x36°	120°	25	8	9,5
DSG 3600	42	M 8x17	93	30°	36°	-	9x36°	120°	25	8	9,5

with end position control

Gripper torque

Gripper torque	without gear	with gear 3 : 1	with gear 9 : 1
DSG 0450	6,5 Nm	19,5 Nm	58,5 Nm
DSG 0900	13 Nm	39 Nm	117 Nm
DSG 1800	32 Nm	96 Nm	288 Nm
DSG 3600	65 Nm	195 Nm	585 Nm

Dimensions with gear

Dimensions with gear	L1 3:1	L2 3:1	L7 3:1	L1 9:1	L2 9:1	L7 9:1
DSG 0450	124,5	127,5	81	150,5	153,5	107
DSG 0900	139	142	95,5	165	168	121,5
DSG 1800	166	170	105	197,5	201,5	136,5
DSG 3600	188	192	127	219,5	223,5	158,5

Pivot angle and weight

	Pivot angle	weight without gear	weight with gear 3 : 1	weight with gear 9 : 1
DSG 0450	max .180°	2,1 kg	3,0 kg	3,8 kg
DSG 0900	max .180°	2,3 kg	3,2 kg	4,0 kg
DSG 1800	max .180°	5,9 kg	8,6 kg	10,4 kg
DSG 3600	max .180°	6,5 kg	9,2 kg	11,0 kg

Ordering number:

- Standard version = 0
- Standard version with end pos. control = 1
- Mounting flange = 2
- Mounting flange and end pos. control = 3
- Installation bracket (on request) = 4
- Installation bracket and end pos. control (on request) = 5

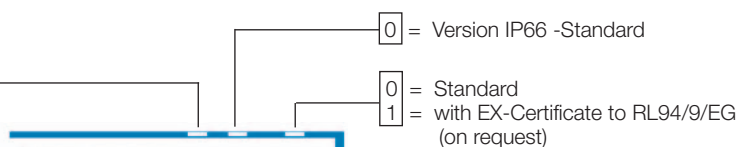

- Drive-rated load torque at 6 bar in Ncm
- Standard = 0
- Gear with reduction 3:1 = 1
- Gear with reduction 9:1 = 3

- 0 = Version IP66 -Standard
- 0 = Standard
- 1 = with EX-Certificate to RL94/9/EG (on request)
- 0 = Standard
- 1 = Silicon free
- 2 = External seals >FPM - FKM< (Viton)
- 3 = with 1 and 2
- 4 = External seals >EPDM - PTFE< (Aceton resistant)
- 5 = with 1 and 4

Ordering example:

DSG 0450 - 4 - 0 - 0 0 2

We deliver:

Three-Pivot-Finger Gripper Type DSG 0450 with installation bracket, IP66 - Standard version with Viton seals

Parallel-Tilting Grippers

PSZ 0200, PSZ 0600, PSZ 0201, PSZ 0601, PSZ 1201, PSZ 3001

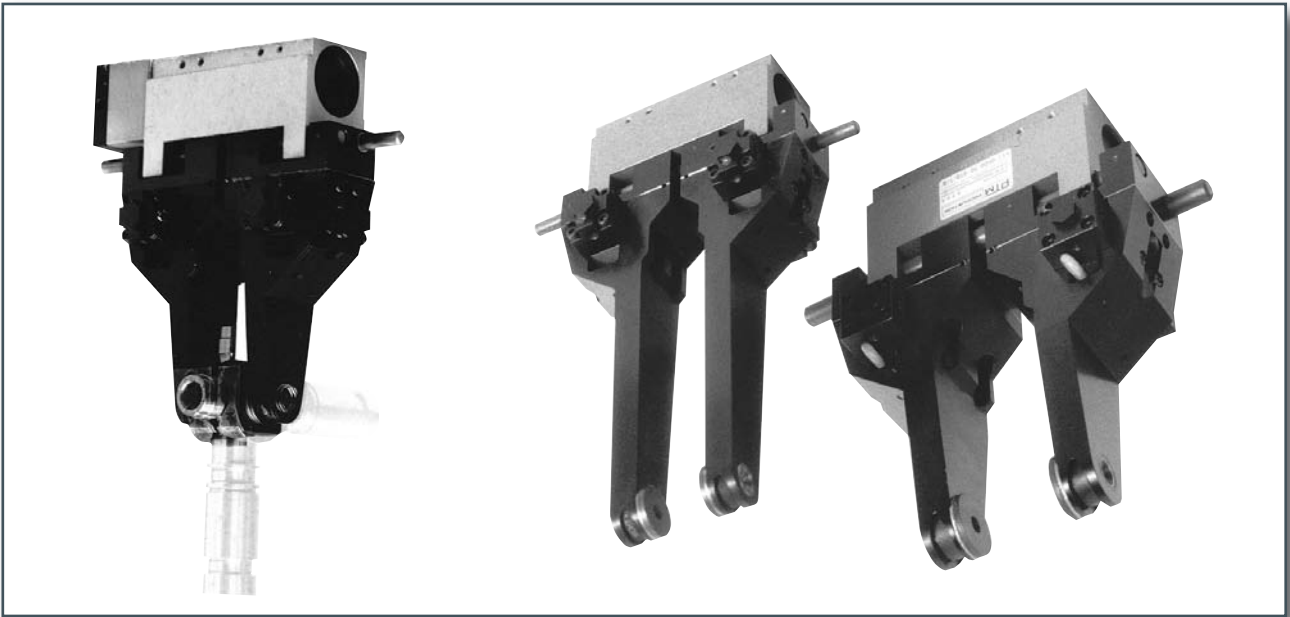

Based on our proven PTM Parallel Grippers – PSM - we designed the PTM Parallel Tilting Gripper – PSZ -. Now you have the possibility to tilt a work piece by a rotation angle of 90° or 180°.

This saves one step in your assembly operation. This design uses the advantages of our PTM Parallel Grippers – PSM – as basic modules to its full advantage. Under normal conditions and in spite of the great length of the tilting jaws, a part will be held in firm and correct position because of the excellent guiding abilities of the Parallel Gripper.

Through the use of our Pneumatic Mini Actuators with end position damping it is possible to have a damped end positioning of the tilting operation.

The Parallel Tilting Grippers – PSZ – are available in two series:

The slim models PSZ 0200 and PSZ 0600, with extremely slim tilting jaws. They are used in case of small space situations.

The robust models PSZ 0201 and PSZ 0601 and also the models PSZ 1201 and PSZ 3001 with strong tilting jaws. They are fitted out with a reinforced plain bearing. To withstand the gripping forces during the tilting operation we also use deep groove ball thrust bearings instead of plain bearings. To control end positioning we use adjustable end stops.

The additional advantages of our Parallel Grippers – PSM – like spring force, several position cylinder and attachment for centering are available for the Parallel Tilting Grippers – PSZ – too.

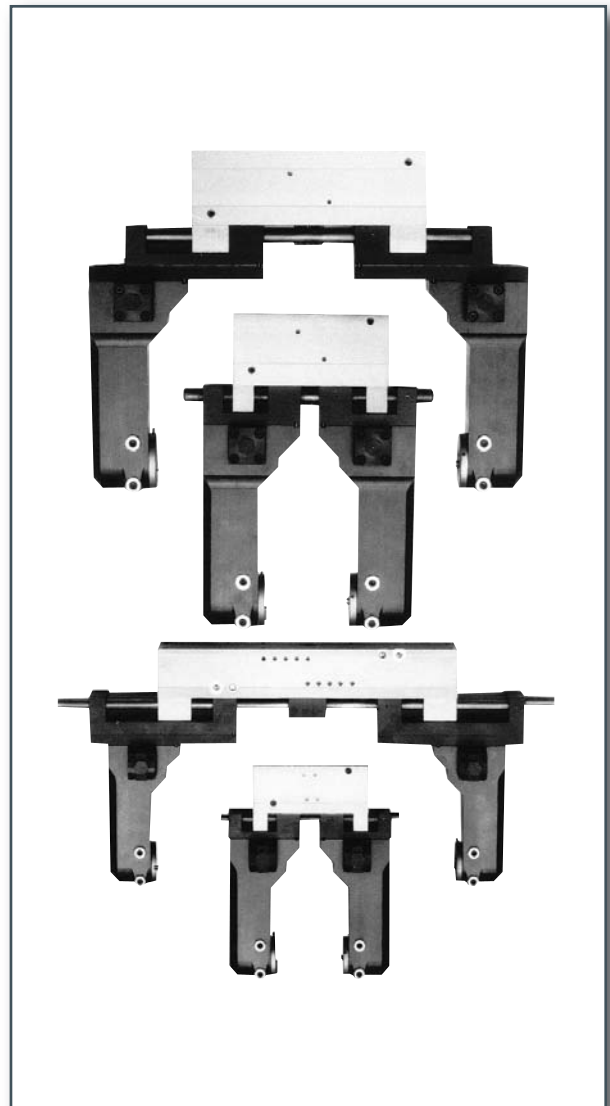

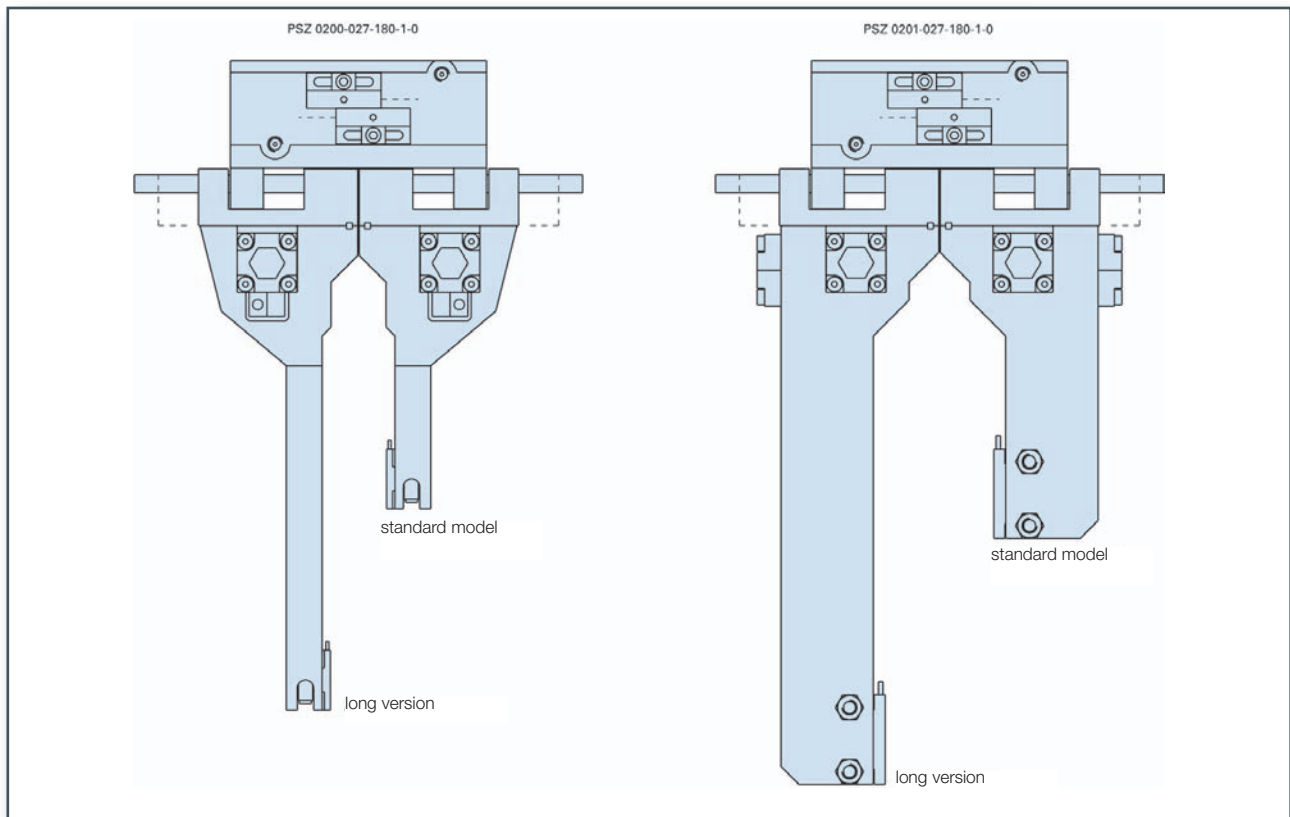

PSZ 0200 and PSZ 0600

- the slim models of Parallel Tilting Grippers, mounted on the proven Parallel Grippers PSMU 0200 and PSMU 0600.
- slim, fingerlike construction of the tilting jaws
- rotation hub for taking up clamping elements
- safety against twist by set screw
- bearing of rotation hub by deep groove ball bearing
- plain bearing for taking up the gripping forces
- toothed belt for drive connection
- all PSZ 0200 and PSZ 0600 are available with elongated tilting jaws !

PSZ 0201, PSZ 0601, PSZ 1201, PSZ 3001

- the more robust models of the well known Parallel Tilting Grippers
- strong, reinforced model of the tilting jaws
- enlarged rotation hub for mounting of clamping elements
- additional safety against twist through keyway
- reinforced bearing of the rotation hub
- deep groove ball thrust bearings instead of plain bearing for taking up the gripping forces
- reinforced toothed belt for drive connection
- adjustable end stops (rotation angle $-10^{\circ}/+5^{\circ}$)
- closed system in tilting area
- all PSZ 0201, PSZ 0601, PSZ 1201 and PSZ 3001 are available with elongated tilting jaws !

Please refer for dimensions and other details to technical specification sheets of Parallel Grippers and Tilting Grippers.

Parallel Tilting Grippers

PSZ 0200, PSZ 0600

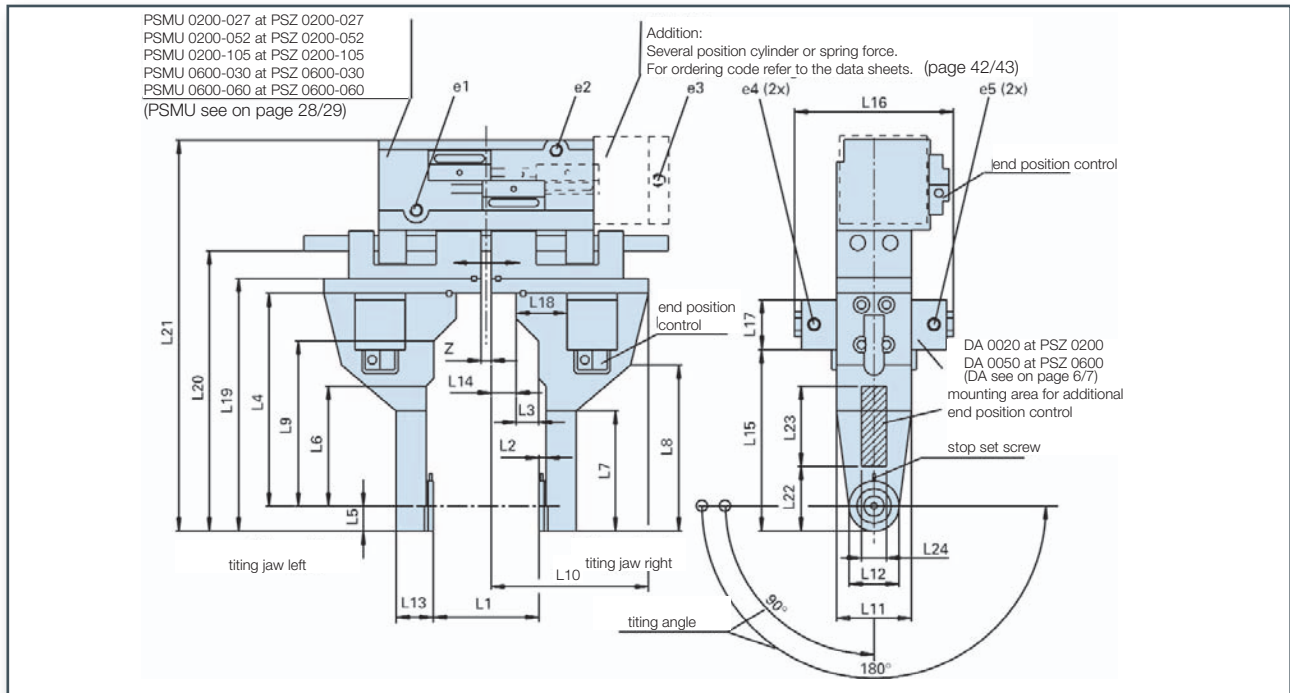

- e1 air connection „Opening“ M5x5
- e2 air connection „Closing“ M5x5
- e3 air connection „second stroke“ M5x6
- e4 air connection „tilting forward“ M5x4
- e5 air connection „tilting backward“ M5x4

PSZ	0200	0600
compressed air	6 bar	6 bar
torque	40 Ncm	100 Ncm
centric gripping force	125 N	250 N
bearing load Co/F _A	200 N/50 N	400 N/100 N

Dimensions of rotation hub for mounting of clamping elements

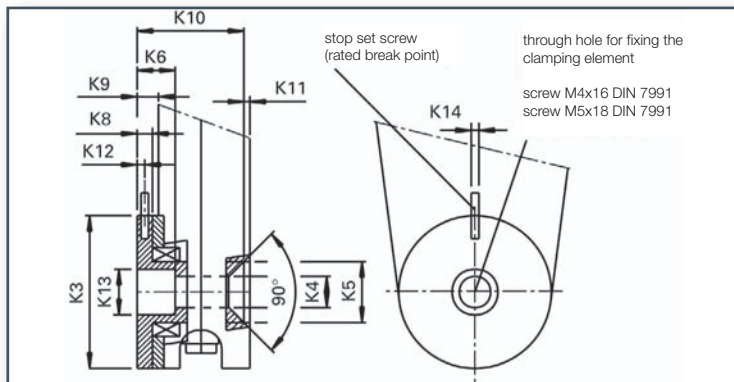

PSZ	0200	0600
ø K3	20 -0,2	26 -0,2
ø K4	4,1	5,1
ø K5	8	10
K6	5	5
K8	2	2,5
K9	2,8	3,3
K10	14	17,7
K11	0,8	0,3
K12	1	1
ø K13	6 H7	7 H7
ø K14	1	1,5

Ordering Code

PSZ XXXX-XXX-XXX-X-X

model code base jaw stroke in mm

Ordering Example you order : **PSZ 0200-027-180-1-2**

we deliver :

Parallel Tilting Gripper model PSZ 0200, with base jaw stroke 27 mm, tilting angle 180°, with end pos. control, opening size 59-86 mm

090 = tilting angle 090°
180 = tilting angle 180°

opening size, see table

0 = basic model
1 = with end position control (sheet end pos. control)

- 1) For special model please give the size L1 min. after the ordering code 2) additional ordering code at PSZ 0200 long version: 1324
 additional ordering code at PSZ 0600 long version: 1325

All dimensions in mm

model	PSZ 0200-027				PSZ 0200-052				PSZ 0200-105				long version 2)
opening size	0	1	2	3	0	1	2	3	0	1	2	3	—
L1 min.	19	39	59	special	19	64	109	special	47	131	215	special	—
L1 max.	46	66	86	model 1)	71	116	161	model 1)	152	236	320	model 1)	—
L2	2,8				2,8				2,8				—
L3	9				9				9				—
L4	85				85				85				+67,5
L5	10				10				10				—
L6	48				48				48				+67,5
L7	48				48				48				+67,5
L8	66				66				66				—
L9	66				66				66				+67,5
L10	53	63	73	53+L14	53	75,5	98	53+L14	108,5	108,5	137	53+L14+X	—
L11	30				30				30				—
L12	20				20				20				—
L13	14,8				14,8				14,8				—
L14	—	10	20	(L1-Z): 2-L3-0.25	—	22,5	45	(L1-Z): 2-L3-0.25	—	42	84	(L1-28.5): 2+0,75-10	—
L15	72,5				72,5				72,5				+67,5
L16 tilting angle 90°	63,7				63,7				63,7				—
L16 tilting angle 180°	73,2				73,2				73,2				—
L17	20x20				20x20				20x20				—
L18	20,4				20,4				20,4				—
L19	95	101	101	101	95	103	103	103	95	103	103	103	+67,5
L20	106	112	112	112	110	118	118	118	110	120,4	120,4	120,4	+67,5
L21	150,3	156,3	156,3	156,3	157	165	165	165	159,2	167,2	167,2	167,2	+67,5
L22	25				25				25				25
L23	33				33				33				100
L24	10				10				10				10
base jaw stroke	2x13,5	2x13,5	2x13,5	2x13,5	2x26	2x26	2x26	2x26	2x52,5	2x52,5	2x52,5	2x52,5	—
weight kg	0,9	1,0	1,0	1,0	1,1	1,2	1,2	1,2	1,6	1,7	1,7	1,7	—
Z	0,5 at base jaw closed								28,5 at base jaw closed				

model	PSZ 0600-030				PSZ 0600-060				long version 2)
opening size	0	1	2	3	0	1	2	3	—
L1 min.	32	52	72	special	32	82	132	special	—
L1 max.	62	82	102	model 1)	92	142	192	model 1)	—
L2	3,3				3,3				—
L3	15				15				—
L4	116				116				+90
L5	13				13				—
L6	74				74				+90
L7	74				74				+90
L8	95,5				95,5				+90
L9	91				91				+90
L10	67,5	77,5	87,5	67,5+L14	67,5	92,5	117,5	67,5+L14	—
L11	44				44				—
L12	26				26				—
L13	18				18				—
L14	—	10	20	(L1-Z): 2-L3-0.75	—	25	50	(L1-Z): 2-L3-0.75	—
L15	101,5				101,5				+90
L16 tilting angle 90°	75,6				75,6				—
L16 tilting angle 180°	87,6				87,6				—
L17	25x25				25x25				—
L18	30				30				—
L19	129	139	139	139	129	139	139	139	+90
L20	143	153	153	153	143	153	153	153	+90
L21	203,5	213,5	213,5	213,5	203,5	213,5	213,5	213,5	+90
L22	31				31				31
L23	56				56				146
L24	14				14				14
base jaw stroke	2x15	2x15	2x15	2x15	2x30	2x30	2x30	2x30	—
weight kg	1,9	2,0	2,0	2,0	2,2	2,3	2,3	2,3	—
Z	0,5 at base jaw closed								

Parallel Tilting Grippers PSZ 0201, PSZ 0601

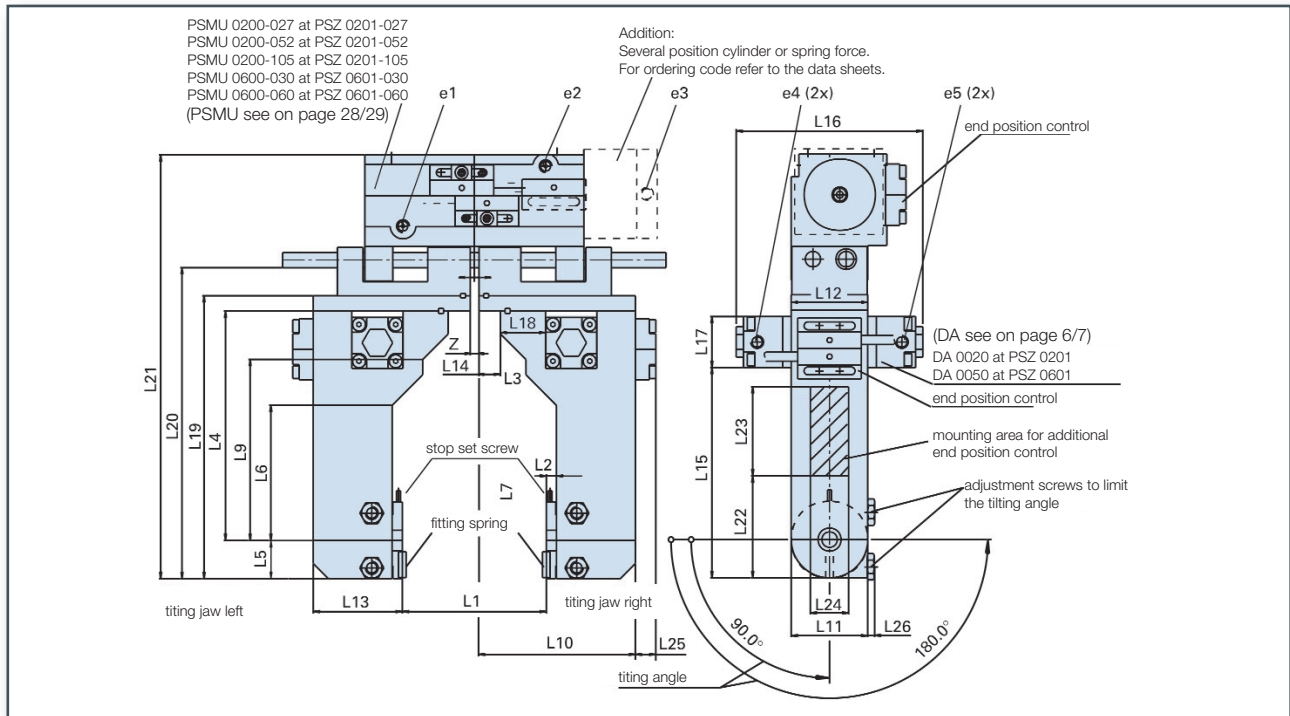

- e₁ air connection „Opening“ M5x5
- e₂ air connection „Closing“ M5x5
- e₃ air connection „second stroke“ M5x6
- e₄ air connection „tilting forward“ M5x4
- e₅ air connection „tilting backward“ M5x4

PSZ	0201	0601
compressed air	6 bar	6 bar
torque	40 Ncm	100 Ncm
centric gripping force	125 N	250 N
bearing load Co/FA	1000 N/400 N	2000 N/800 N

Dimensions of rotation hub for mounting of clamping elements

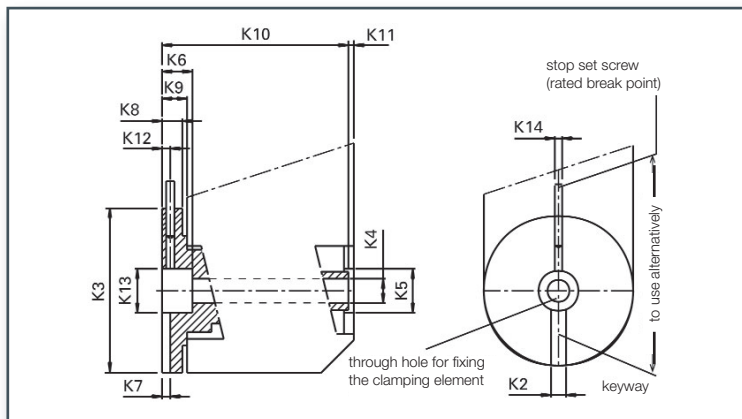

PSZ	0201	0601
K2	3 P9	4 P9
ø K3	30 h7	38 h7
ø K4	4,4	5,4
ø K5	8	10
K6	5	8
K7	1,5	2
K8	3,7	4,7
K9	4	5
K10	34	41
K11	1	3
K12	1,5	2
ø K13	8 H7	10 H7
K14	1,5	2

Ordering Code

PSZ XXXX-XXX-X-X

model code base jaw stroke in mm opening size, see table

090 = tilting angle 090°
180 = tilting angle 180°

0 = basic model
1 = with end position control (sheet end pos. control)

Ordering Example you order : PSZ 0201-027-180-1-2

we deliver : Parallel Tilting Gripper model PSZ 0201, with base jaw stroke 27 mm, tilting angle 180°, with end pos. control, opening size 76,5-103,5 mm

1) for special model please give the size L1 min. after the ordering code.

2) additional ordering code at PSZ 0201 long version: 2291
additional ordering code at PSZ 0601 long version: 2292

All dimensions in mm

model	PSZ 0201-027				PSZ 0201-052				PSZ 0201-105				long version 2)
opening size	0	1	2	3	0	1	2	3	0	1	2	3	—
L1 min.	36,5	56,5	76,5	special	36,5	81,5	126,5	special	64,5	148,5	232,5	special	—
L1 max.	63,5	83,5	103,5	model 1)	88,5	133,5	178,5	model 1)	169,5	253,5	337,5	model 1)	—
L2	4				4				4				—
L3	10				10				10				—
L4	90				90				90				+75
L5	15				15				15				—
L6	53				53				53				+75
L7	68				68				68				+75
L9	71				71				71				+75
L10	53	63	73	53+L14	53	75,5	98	53+L14	108,5	108,5	137	53+L14+X	—
L11	30				30				30				—
L13	35				35				35				—
L14	—	10	20	(L1-Z): 2-L3-8	—	22,5	45	(L1-Z): 2-L3-8	—	42	84	(L1-28,5): 2-L3-8	—
L15	82,5				82,5				82,5				+75
L16 tilting angle 90°	63,7				63,7				63,7				—
L16 tilting angle 180°	73,2				73,2				73,2				—
L17	20x20				20x20				20x20				—
L18	17,7				17,7				17,7				—
L19	105	111	111	111	105	113	113	113	105	113	113	113	+75
L20	116	122	122	122	120,2	128,2	128,2	128,2	122,7	130,7	130,7	130,7	+75
L21	160,3	166,3	166,3	166,3	167	175	175	175	169	177	177	177	+75
L25	8				8				8				—
L26	2,8				2,8				2,8				—
base jaw stroke	2x13,5	2x13,5	2x13,5	2x13,5	2x26	2x26	2x26	2x26	2x52,5	2x52,5	2x52,5	2x52,5	—
L22	40				40				40				40
L23	35				35				35				110
L24	15				15				15				15
weight kg	1,3	1,4	1,4	1,4	1,5	1,6	1,6	1,6	1,9	2,0	2,0	2,0	—
Z	0,5 at base jaws closed								28,5 at base jaws closed				—
Typ	PSZ 0601-030				PSZ 0601-060				long version 2)				
opening size	0	1	2	3	0	1	2	3	—				
L1 min.	47,5	67,5	87,5	special	47,5	97,5	147,5	special	—				
L1 max.	77,5	97,5	117,5	model 1)	107,5	157,5	207,5	model 1)	—				
L2	5				5				—				
L3	15				15				—				
L4	121				121				+108				
L5	19				19				—				
L6	78,5				78,5				+108				
L7	97,5				97,5				+108				
L9	98				98				+108				
L10	67,5	77,5	87,5	67,5+L14	67,5	92,5	117,5	67,5+L14	—				
L11	38				38				—				
L13	44				44				—				
L12	44				44				—				
L14	—	10	20	(L1-Z): 2 -L3-8,5	—	25	50	(L1-Z): 2 -L3-8,5	—				
L15	95				95				+108				
L16 tilting angle 90°	75,6				75,6				—				
L16 tilting angle 180°	87,6				87,6				—				
L17	25x25				25x25				—				
L18	24,5				24,5				—				
L19	140	150	150	150	140	150	150	150	+108				
L20	154	164	164	164	154	164	164	164	+108				
L21	214,5	224,5	224,5	224,5	214,5	224,5	224,5	224,5	+108				
L25	8				8				—				
L26	3				3				—				
base jaw stroke	2x15	2x15	2x15	2x15	2x30	2x30	2x30	2x30	—				
L22	48				48				48				
L23	50				50				158				
L24	18				18				18				
weight kg	2,9	3,0	3,0	3,0	3,5	3,6	3,6	3,6	—				
Z	0,5 at base jaws closed								—				

Parallel Tilting Grippers PSZ 1201, PSZ 3001

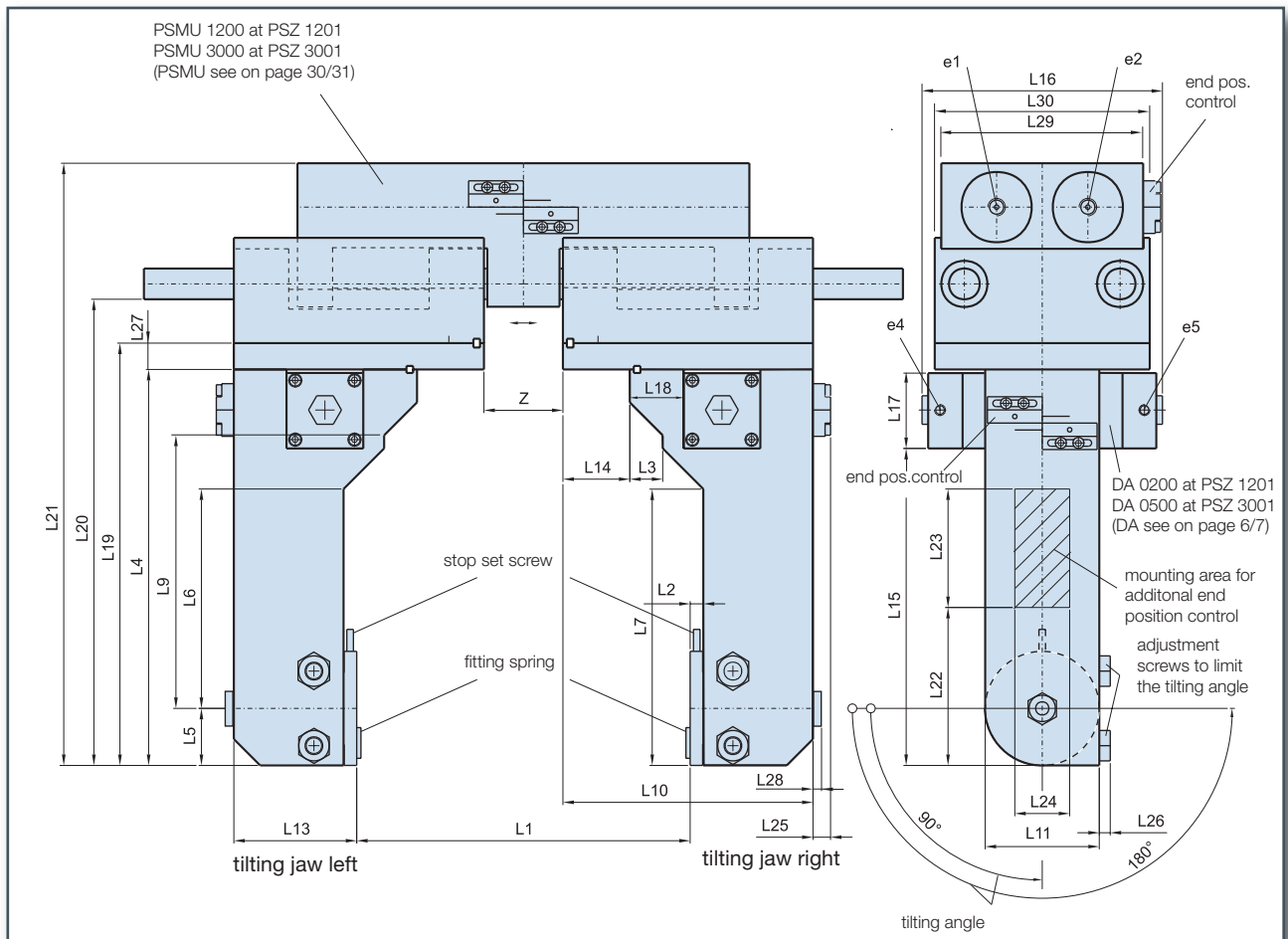

- e1 air connection "Opening" R1/8x8 / R1/4x10
- e2 air connection "Closing" R1/8x8 / R1/4x10
- e4 air connection "tilting forward" M5x5,5 / R1/8x8
- e5 air connection "tilting backward" M5x5,5 / R1/8x8

PSZ	1201	3001
compressed air	6 bar	6 bar
torque	400 Ncm	1000 Ncm
centric gripping force	600 N	1500 N
bearing load Co/FA	4000 N/1200 N	8000 N/3800 N

Dimensions of rotation hub for mounting of clamping elements

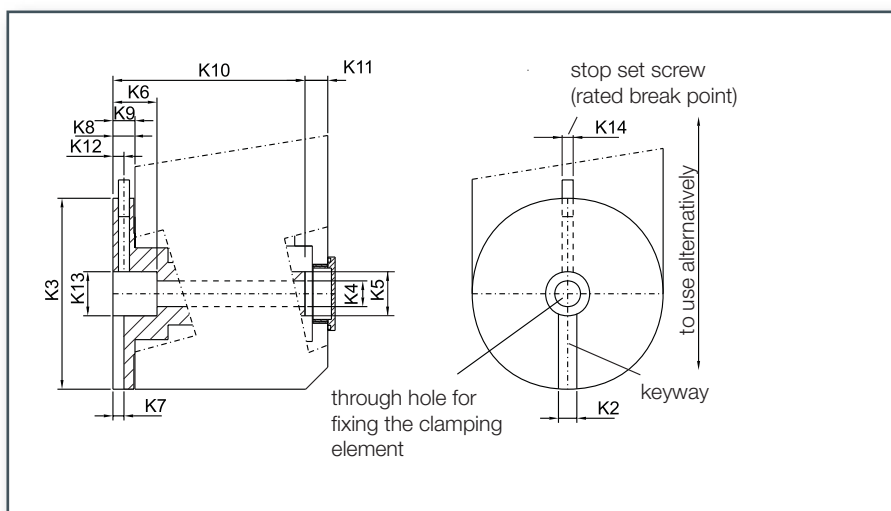

PSZ	1201	3001
K2	5,0 P9	6,0 P9
∅ K3	52,0 h7	65,0 h7
∅ K4	7,0	9,0
∅ K5	12,0	15,0
K6	10,0	15,0
K7	3,0	3,5
K8	5,7	7,7
K9	6,0	8,0
K10	52,3	67,5
K11	6,2	9,0
K12	3,0	3,5
∅ K13	12,0 H7	14,0 H7
K14	3,0	3,0

model	PSZ 1201-080		PSZ 3001-080	
	basic model	special model	basic model	special model
opening size	0	3	0	3
L1 min.	184.0	on request	227.0	on request
L1 max.	264.0	on request	307.0	on request
L2	6.0	6.0	8.0	8.0
L3	15.0	15.0	16.0	16.0
L4	180.5	180.5	226.5	226.5
L5	26.0	26.0	32.5	32.5
L6	100.0	100.0	114.5	114.5
L7	126.0	126.0	147.0	147.0
L9	124.5	124.5	156.7	156.7
L10	114.0	86.0+L14	122.0	113.0+L14
L11	52.0	52.0	65.0	65.0
L13	58.5	58.5	76.5	76.5
L14	28.0	(L1-Z) : 2-27.5	9.0	(L1-Z) : 2-36.5
L15	144.5	144.5	175.5	175.5
L16 tilting angle 90°	90.6	90.6	129.6	129.6
L16 tilting angle 180°	109.6	109.6	162.6	162.6
L17	35x35	35x35	50x50	50x50
L18	26.5	26.5	31.5	31.5
L19	180.5	180.5+L27	226.5	226.5+L27
L20	200.5	200.5+L27	252.5	252.5+L27
L21	262.5	262.5+L27	351.5	351.5+L27
L22	72.0	72.0	75.0	75.0
L23	54.0	54.0	65.0	65.0
L24	25.0	25.0	35.0	35.0
L25	8.0	8.0	8.0	8.0
L26	5.0	5.0	5.0	5.0
L27	—	min. 20.0	—	min. 20.0
L28	2.0	2.0	2.0	2.0
L29	92.0	92.0	134.0	134.0
L30	98.0	98.0	141.0	141.0
base jaw stroke in mm	2x40	2x40	2x40	2x40
weight kg	8.8	min. 8.8	13.3	min. 13.3
Z	73.0 at „base jaws closed”		136.0 at „base jaws closed”	

All dimensions in mm

Ordering Code

PSZ XXXX-XXX-XXX-X-X

| model code
 | base jaw stroke in mm
 | opening size

| 090 = tilting angle 090°
| 180 = tilting angle 180°

| 0 = basic model
| 1 = with end position control (sheet end pos. control)

Ordering Example you order : PSZ 1201-080-180-1-0

we deliver : Parallel Tilting Gripper model PSZ 1201, with base jaw stroke 80 mm, tilting angle 180°, with end pos. control, opening size 184-264 mm

For special model please give size L1 min. after the ordering code!

Several Position Cylinder for PSM, PSMU, PSZ

Addition : Several Position Cylinder for second stroke ZMZ

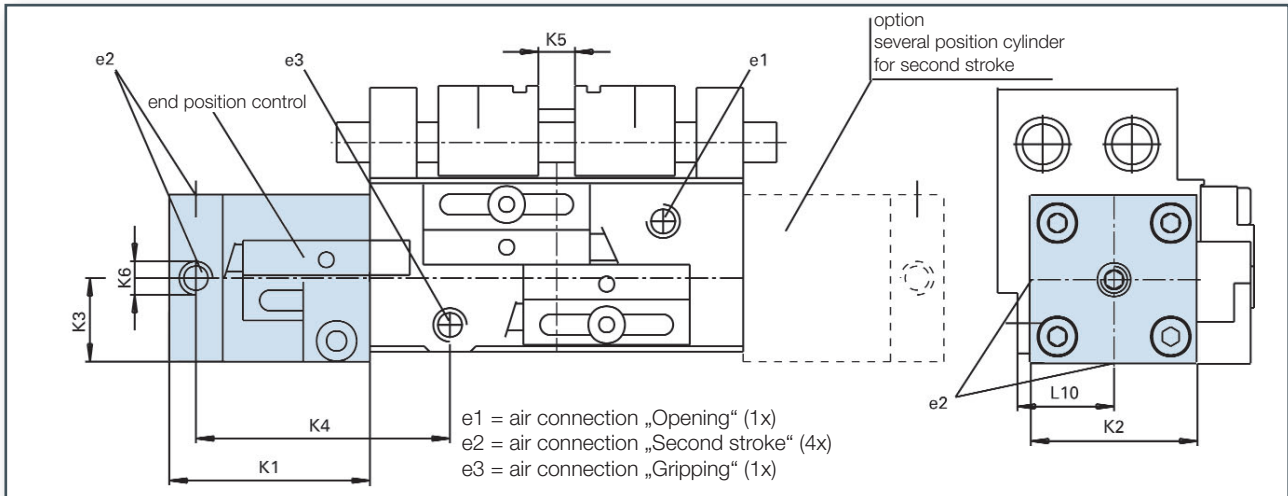

ZMZ	0050-011	0050-029	0050-052	0200-013	0200-27	0200-52	0200-105	0600-016	0600-030	0600-060
for model	PSM/PSMU 0050-011	PSM/PSMU 0050-029	PSM/PSMU 0050-052	PSM/PSMU/ 0200-013	PSM/PSMU/ PSZ 0200-027	PSM/PSMU/ PSZ 0200-052	PSM/PSMU/ PSZ 0600-105	PSM/PSMU/ PSZ 0600-016	PSM/PSMU/ PSZ 0600-030	PSM/PSMU/ PSZ 0600-060
K1	30,1	30,1	41,5	31,3	31,3	43,8	70,3	57,3	57,3	57,3
K2	25x25	25x25	25x25	35x35	35x35	35x35	35x35	50x50	50x50	50x50
K3	12,5	12,5	12,5	17,5	17,5	17,5	17,5	25	25	25
K4	32,1	38,1	66,5	37,3	42,3	67,8	108,8	58,8	61,8	61,8
K5 min.	5	5	5	5	5	5	5	5	5	5
K6	M5x5,5	M5x5,5	M5x5,5	M5x6	M5x6	M5x6	M5x6	R1/8x9	R1/8x9	R1/8x9
L10	17,5	17,5	17,5	19	19	19	19	35	35	35

Refer to technical specification sheets for dimensions and other details!

All dimensions in mm

Ordering Code

ZMZ XXXX-XXX-X/XX

second stroke K5 in mm

model code

0 = basic model
1 = with end position control (sheet end pos. control)

Ordering Example

you order : ZMZ 0200-013-0/08

we deliver : Addition : Several Position Cylinder for model PSM/PSMU 0200-013, basic model, second stroke 8 mm

Mounting Hole for Ejector

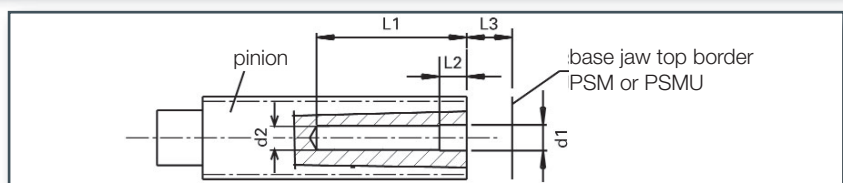

model	PSM	PSMU	PSM	PSMU	PSM	PSMU	PSM	PSMU	PSM	PSMU	PSM	PSMU
	0030-007 0030-030 0030-052		0050-011 0050-029 0050-052		0200-013 0200-027		0200-052		0200-105		0600-016 0600-030 0600-060	
ø d1	2,8 H6	2,8 H6	2,8 H6	2,8 H6	2,8 H6	2,8 H6	2,8 H6	2,8 H6	2,8 H6	2,8 H6	10 H6	10 H6
ø d2	2,6	2,6	2,6	2,6	2,6	2,6	2,6	2,6	2,6	2,6	8 H11	8 H11
L1	16,5	16,5	16,5	16,5	16,5	16,5	16,5	16,5	16,5	16,5	35	35
L2	3	3	3	3	3	3	3	3	3	3	5	5
L3	5,3	9,8	5	10,5	4,5	10,2	8,7	16,9	8,7	18,9	4,5	12,5

Addition : Spring Force ZFS, with a mechanical spring for internal or external gripping force

Internal or external gripping force can also be used as safety in case of failure of air pressure!

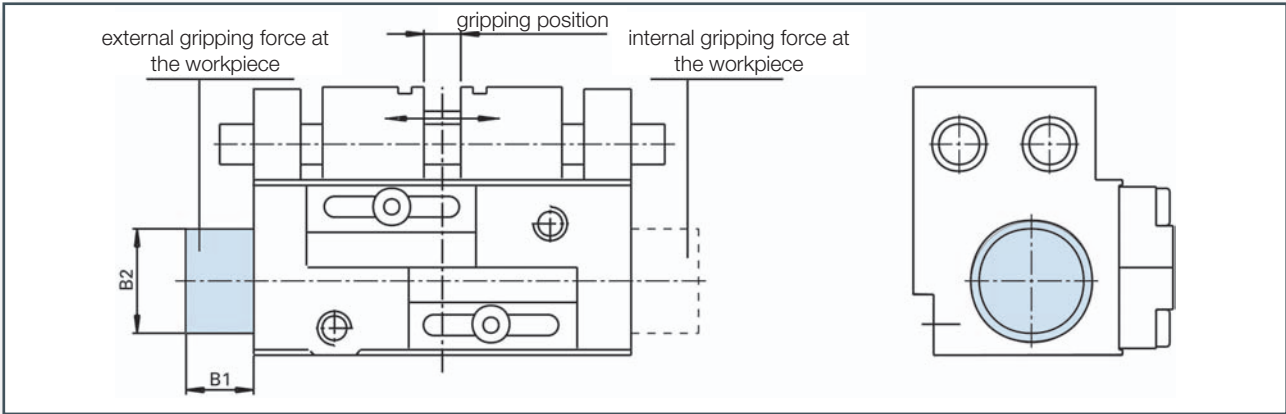

ZFS	0030-007	0030-011	0030-052	0050-011	0050-029	0050-052	0200-013	0200-27	0200-52	0200-105	0600-016	0600-030	0600-060
for model	PSM/PSMU 0030-007	PSM/PSMU 0030-011	PSM/PSMU 0030-052	PSM/PSMU 0050-011	PSM/PSMU 0050-029	PSM/PSMU 0050-052	PSM/PSMU/ 0200-013	PSM/PSMU/ PSZ 0200-27	PSM/PSMU/ PSZ 0200-52	PSM/PSMU/ PSZ 0600-105	PSM/PSMU/ PSZ 0600-016	PSM/PSMU/ PSZ 0600-030	PSM/PSMU/ PSZ 0600-060
B1	7,2	on	on	9,5	on	on	9,8	29,3	51,3	51,3	10	on	on
ø B2	11	request	request	15,5	request	request	24,5	28	28	28	33,5	request	request

Refer to technical specification sheets for dimensions and other details!

All dimensions in mm

Ordering Code

ZFS XXXX - XXX - X / XXX / XXX

model code centric gripping force in N gripping position

Ordering Example you order : ZFS 0050 - 011 - A / 035 - XXX

we deliver : Addition : Spring force for model PSM 0050-011- with external gripping force at the workpiece

A = for external gripping force at the workpiece
B = for internal gripping force at the workpiece

Attachment for centering for PSM, PSMU, PSZ, all Parallel Grippers are deliverable with attachment for centering

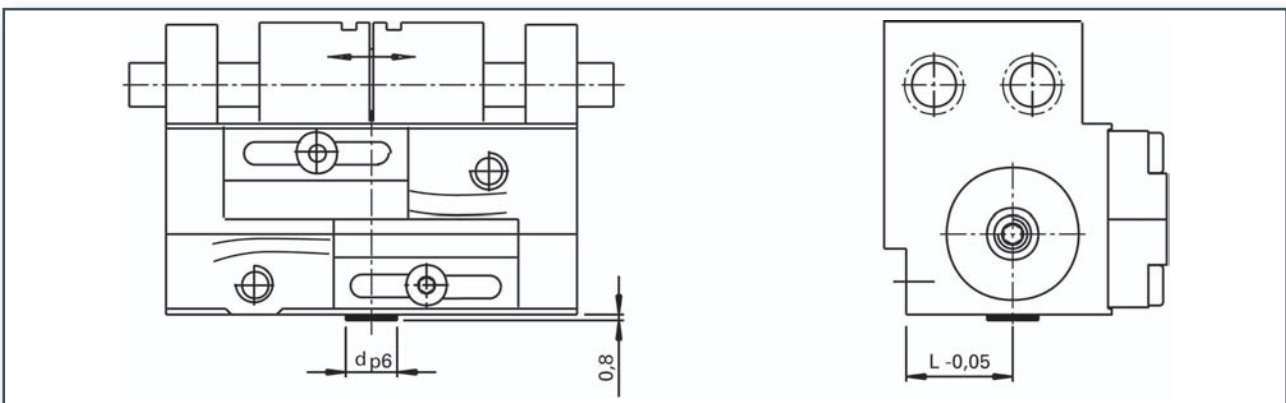

PSM/PSMU PSZ	0030	0050	0200	0600
d p6	7	10	12	26
L -0,05	8,5	10,5	12	17,1

Ordering Code

Like PSM, PSMU or PSZ only with addition of „Attachment for centering“

Ordering Example

PSMU 0050-011-100-0 with attachment for centering

End Position Control with LED

Technical data for End Position Control, electronic version

- end position control with LED
- contact-free adjustable
- switch elements: permanent magnet, PERMALLOY-SENSOR
- connection cable: length about 2 m (6.5 ft), 3 cores, highly flexible
- adjustment of connections
- protected against short circuit and wrong polarity
- temperature range: -20°C to +80°C (4° to 176°F)
- voltage: 6-35 V
- current: 250 mA
- using current: smaller than 4 mA
- switching frequency: max. 500 Hz
- repeatable switching accuracy: +/- 0,1 mm
- switching time: 1ms
- protection: JP 66
- no contact bouncing
- high life expectancy, no moving parts
- standard version PNP

End position control, electronic version			
additional Ordering Code			
for model	pluggable **	connection cable 5 m highly flexible	NPN
DA...	0879	0887	0587
PSM...	0879	0887	0587
PSMU...	0879	0887	0587
PSM+ZMZ...	--	1281	1285
PSMU+ZMZ...	--	1281	1285
LM...	0879	0887	0587
DM...	0879	0887	0587
DSK...	0880	1282	0588
SM...	0879	0887	0587
PSZ...	--	1283	892
PSZ+ZMZ	--	1284	1286
HPA...	0879	0887	0587

Ordering Example

Actuator DA 0200-185-1-0 with end position control, electronic version, pluggable :

DA 0200-185-1-0 +0879

Endschalter als Ersatzteile				
		ordering code	additional ordering code	
for model		electronic version	connection cable 5 m highly flexible	NPN
DA 0050-DA 6000 PSM 0050-PSM 0600 PSMU 0050-PSMU 0600 DSK 0050+DSK 0200 DM 0050-DM 0500 SM 0020-SM 0200 LM 0050-LM 0500 DSK 0020* PSZ* HPA		7399	0886	0362
DA 0020+PSM 0030 DM 0020+PSMU 0030 DSK 0020*		7875	0886	0362
ZMZ 0050-ZMZ 0600*		7878	0886	0362
ZMZ 0030		7877	0886	0362
PSZ 0200+PSZ 0600		7876	0886	0362
DA 0050-DA 6000 PSM+PSMU 0050-52 PSM 0200-PSM 0600 PSMU 0200-PSMU 0600 DSK 0200+DM 0050-180 DM 0200-DM 0500 SM 0020-SM 0200 LM 0050-LM 0500 PSZ* HPA	end position switch without connection cable, pluggable 	7885	--	0362
DA 0020+PSM 0030 DM 0020-180+PSMU 0030		7888	--	0362
connection cable, pluggable Attention: not pluggable for model **		7889	0886	-

* Different end position switches are possible, please consult factory or catalog.

** Attention:

not pluggable for model:
PSM 0050-011/
PSM 0050-029
DM 0020-090/
DM 0050-090
DSK 0020-090/
DSK 0020-180
DSK 0050-090/
DSK 0050-180

Ordering Example

End Position Switch, electronic version, with connection cable highly flexible, 5 m long, as replacement part:

7399+0886

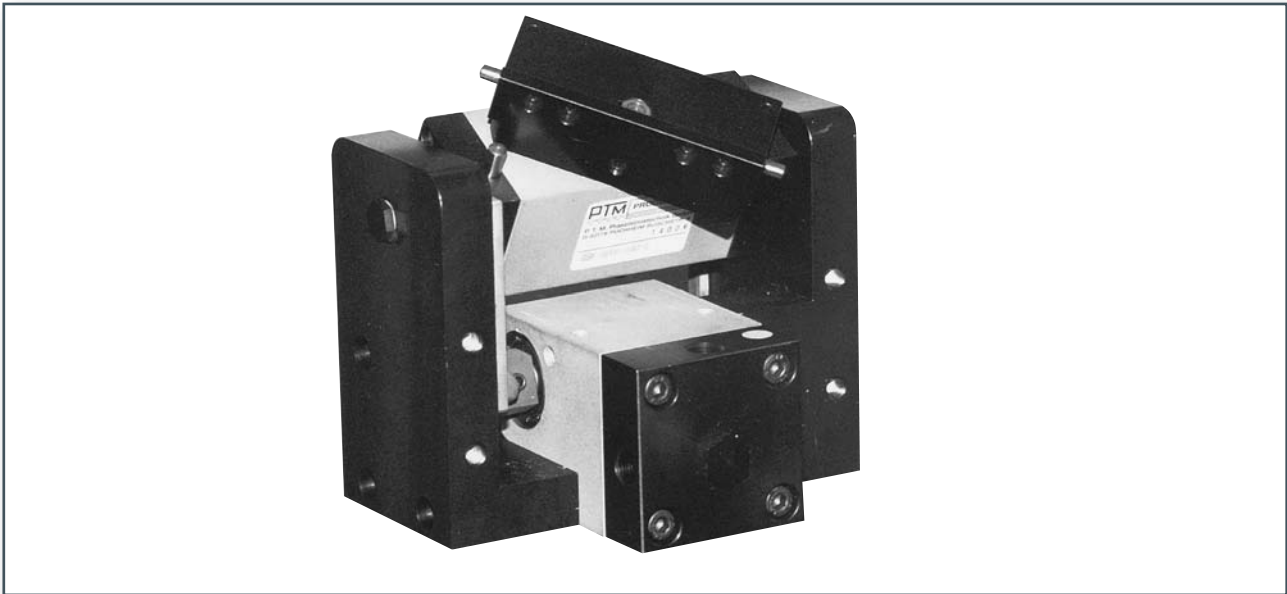

The PTM-Linear Modules – LM – work with our PTM-Actuators. In contrast to the normal linear units, the PTM-Linear Modules use a crank. Therefore there are many advantages. This causes a sinucidal move of the slide with high positioning accuracy and smooth end positioning. The reduced end speed is supported by the end position damping of the PTM-Actuators – DA –. The movements of the slide will be shock-free.

The slide strokes are continuous adjustable between 0 and 25, 30, 52 or 90 mm.

The PTM-Tilting Module – SM – in connection with a fix mounted Parallel Gripper – PSM – is able to tilt a workpiece by 90° from a horizontal position to a vertical position and back. The position of the workpiece will not be changed.

The PTM-Double Tilting Head – DSK – gives the additional possibility to tilt a workpiece with a defined tilting angle of 90° or 180°. Other tilting angles on request.

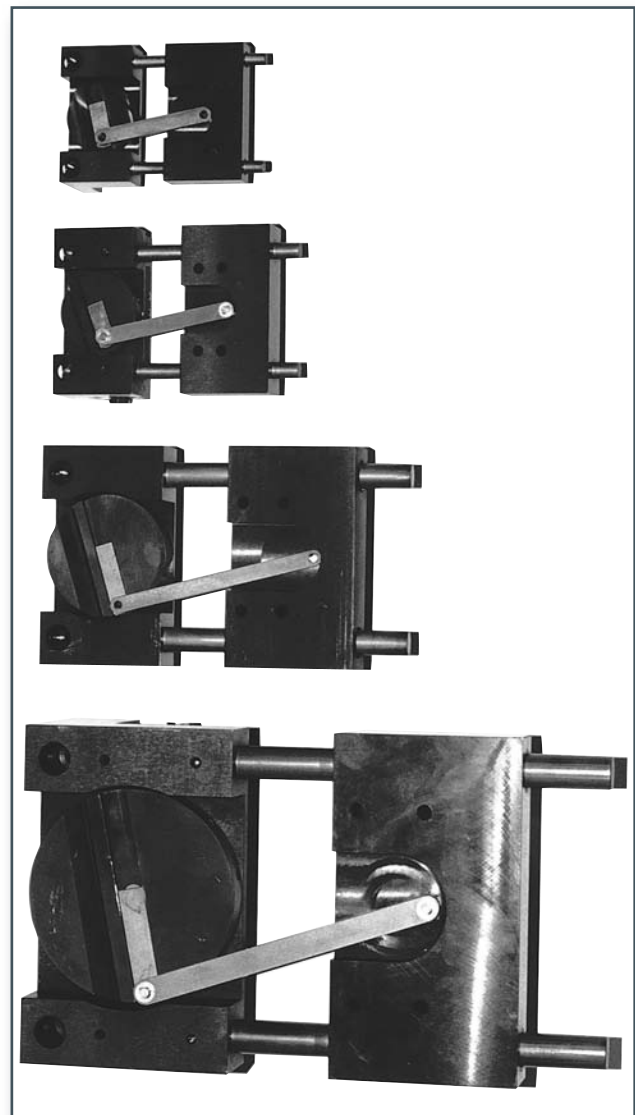

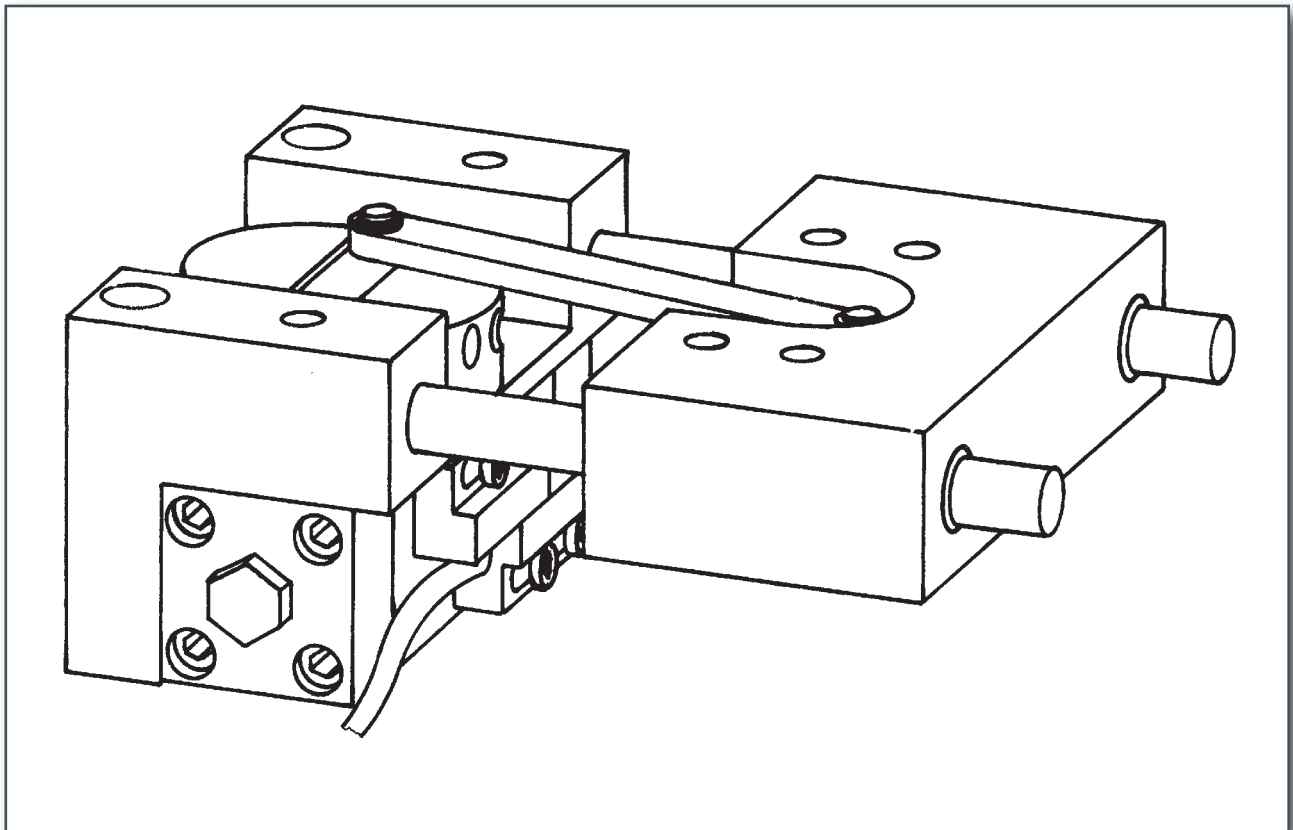

Material:	<ul style="list-style-type: none">- aluminum hard or black anodized- steel parts of stainless material or corrosion resistant- shorttime gas nitration
Operating or mounting position:	<ul style="list-style-type: none">- any position desired
Operating temperature:	<ul style="list-style-type: none">- -10° to +80°C (4° to 176°F)
Operating media:	<ul style="list-style-type: none">- filtered oiled or filtered oil-free air- Attention: only oil-free air should be used at low rotation speed as interruptions could harm the smooth process
Operation pressure:	<ul style="list-style-type: none">- maximum 6 bar (specs are based on 6 bar = 88 psi)
Jaw stroke:	<ul style="list-style-type: none">- sinucidal movement- stroke range adjustable via dovetail guides with clamping screw
Guide:	<ul style="list-style-type: none">- precision grinded guides- stainless steel shafts and ball-type bushings
Actuation:	<ul style="list-style-type: none">- Pneumatic Mini Actuator with end position damping
End position control with LED:	<ul style="list-style-type: none">- please consult our sheet „End position control“ (Page 44).
Installation recommendation:	<ul style="list-style-type: none">- to ensure long life of our devices the use of throttle valves is highly recommended.

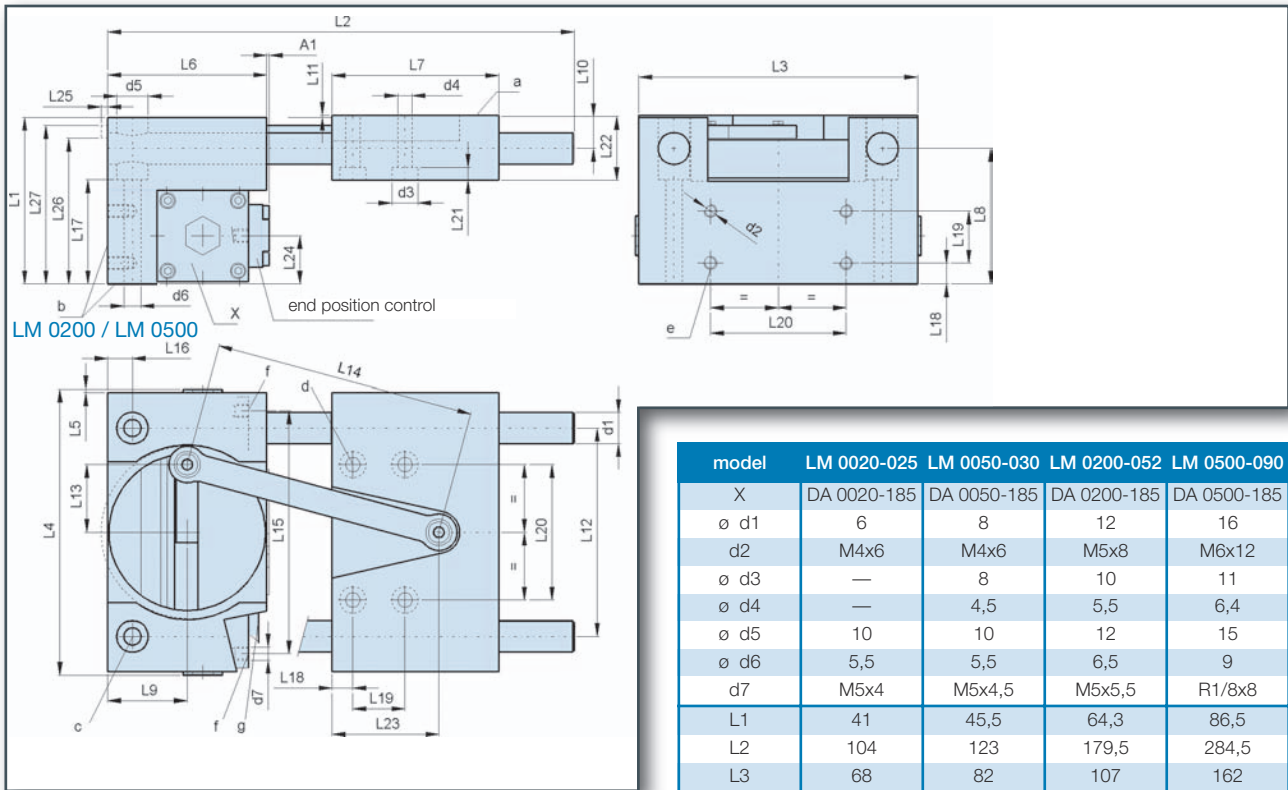

LM 0200 / LM 0500

LM 0020 / LM 0050

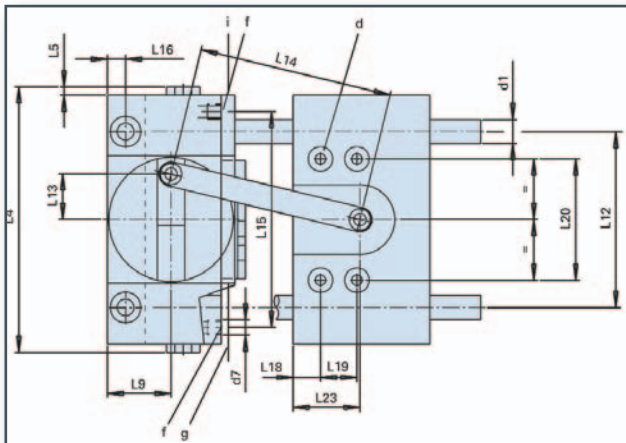

- a, b mounting surface
- c, d, e mounting alternatives
- f 2 threaded holes for air connection
- g connection cable for end position control

- A model with end position control
- X model of actuator DA

model	LM 0020-025	LM 0050-030	LM 0200-052	LM 0500-090
X	DA 0020-185	DA 0050-185	DA 0200-185	DA 0500-185
∅ d1	6	8	12	16
d2	M4x6	M4x6	M5x8	M6x12
∅ d3	—	8	10	11
∅ d4	—	4,5	5,5	6,4
∅ d5	10	10	12	15
∅ d6	5,5	5,5	6,5	9
d7	M5x4	M5x4,5	M5x5,5	R1/8x8
L1	41	45,5	64,3	86,5
L2	104	123	179,5	284,5
L3	68	82	107	162
L4	73,6 +0,6 -0,8	87,6 +0,6 -0,8	109,6 +0,6 -0,8	162,6 +0,6 -0,8
L5	2,8	2,8	1,3	0,3
L6	37	42	61	103
L7	40	45	64	90
L8	33,5	34,5	52	71
L9	18,5	21	30,5	51,5
L10	7,5	11	12,3	15,5
L11	0,3	0,5	0,3	0,5
L12	53	58	80	130
L13 max.	12,5	15	26	45
L14	53	64	100	143
L15	56,8 ±0,4	71,2 ±0,4	93,2 ±0,4	141,2 ±0,4
L16	6	6	9,5	15
L17	27	27	40	53
L18	6	9	8	12
L19	12	12	20	32
L20	35	40	52	90
L21	—	4	5	8
L22	15	22	24,5	31
L23	20	22	41	45
L24	10	13	18,5	26
L25	—	—	2,5	1,9
L26	—	—	55,9	76,4
L27	—	—	60,8	81,4
A1	2	3,5	1	—
stroke in mm	25	30	52	90
weight in kg	0,3	0,6	1,5	4,7

Ordering Code



model code max. stroke

- 0 = basic model
- 1 = with end position control (sheet "end position control")

Ordering Example

you order :

LM 0050-030-1

we deliver :

Linear Module model LM 0050,
max. stroke 30 mm,
with end position control

Tilting Module

SM 0020, SM 0050, SM 0200

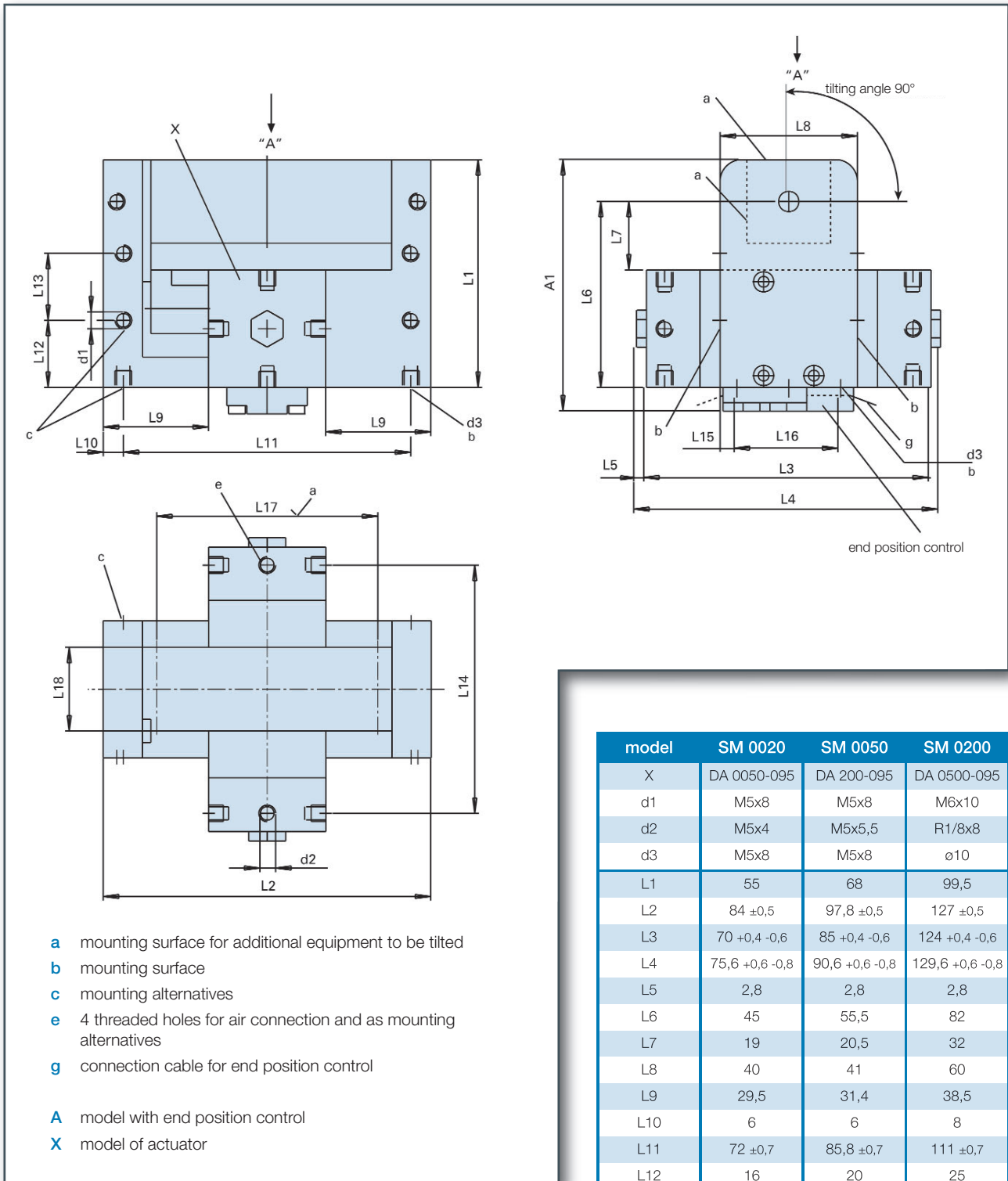

model	SM 0020	SM 0050	SM 0200
X	DA 0050-095	DA 200-095	DA 0500-095
d1	M5x8	M5x8	M6x10
d2	M5x4	M5x5,5	R1/8x8
d3	M5x8	M5x8	ø10
L1	55	68	99,5
L2	84 ±0,5	97,8 ±0,5	127 ±0,5
L3	70 +0,4 -0,6	85 +0,4 -0,6	124 +0,4 -0,6
L4	75,6 +0,6 -0,8	90,6 +0,6 -0,8	129,6 +0,6 -0,8
L5	2,8	2,8	2,8
L6	45	55,5	82
L7	19	20,5	32
L8	40	41	60
L9	29,5	31,4	38,5
L10	6	6	8
L11	72 ±0,7	85,8 ±0,7	111 ±0,7
L12	16	20	25
L13	16	20	30
L14	59,2 ±0,4	74,2 ±0,4	108,2 ±0,4
L15	5	5	5
L16	30	31	50
L17	50	65	88
L18	20x20	25x25	35x35
A1	63	76	107,5
"A" kg	4,0	6,0	10,0
weight in kg	0,3	0,6	1,7

Ordering Code

SM XXXX - X

0 = basic model
 1 = with end position control (sheet "end position control")

model code

Ordering Example

you order : **SM 0050 - 1**

we deliver :
 Tilting Module model SM 0050.
 with end position control

Double Tilting Head DSK 0020, DSK 0050, DSK 0200

Brief technical data

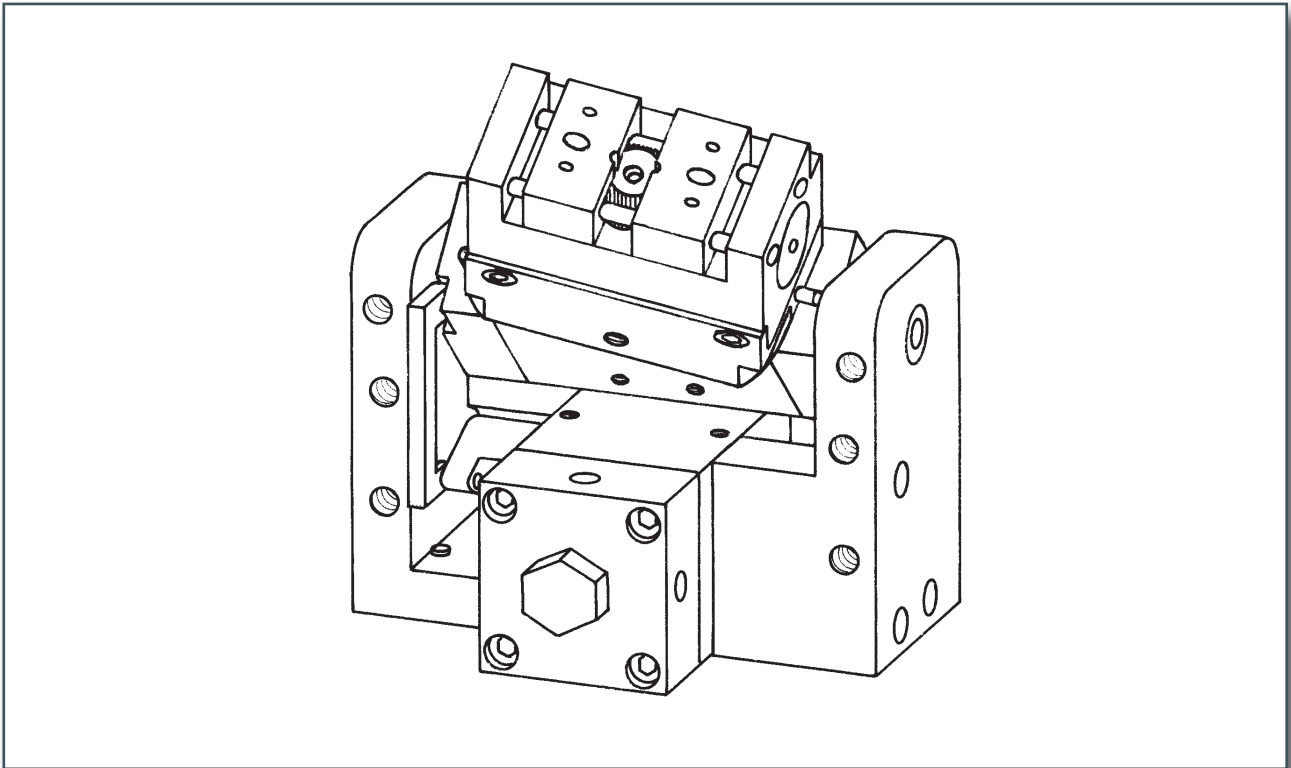

Material:	<ul style="list-style-type: none">- aluminum hard or black anodized- steel parts of stainless material or corrosion resistant- shorttime gas nitration
Operating or mounting position:	<ul style="list-style-type: none">- any position
Operating temperature:	<ul style="list-style-type: none">- -10° to +80°C (14° to 176°F)
Operating media:	<ul style="list-style-type: none">- filtered oiled or filtered oil-free air- Attention : only oil-free air should be used at low rotation speed as interruptions could harm the smooth process
Operating pressure:	<ul style="list-style-type: none">- maximum 6 bar (specs are based on 6 bar = 88psi)
Movement:	<ul style="list-style-type: none">- tilting 90°- rotation 180°
Actuation:	<ul style="list-style-type: none">- Pneumatic Mini Actuator with end position damping
End position control with LED:	<ul style="list-style-type: none">- please consult our sheet „End position control“
Model and installation accessories:	<ul style="list-style-type: none">- the adapter or mounting surface, which is delivered with the basic unit, is prepared for the mounting of our Parallel Gripper PSM. However any other equipment of the customers choice (for example suction grippers) can be mounted.
Installation recommendation:	<ul style="list-style-type: none">- to ensure long life of our devices the use of throttle valves is highly recommended.

Double Tilting Head

DSK 0020, DSK 0050, DSK 0200

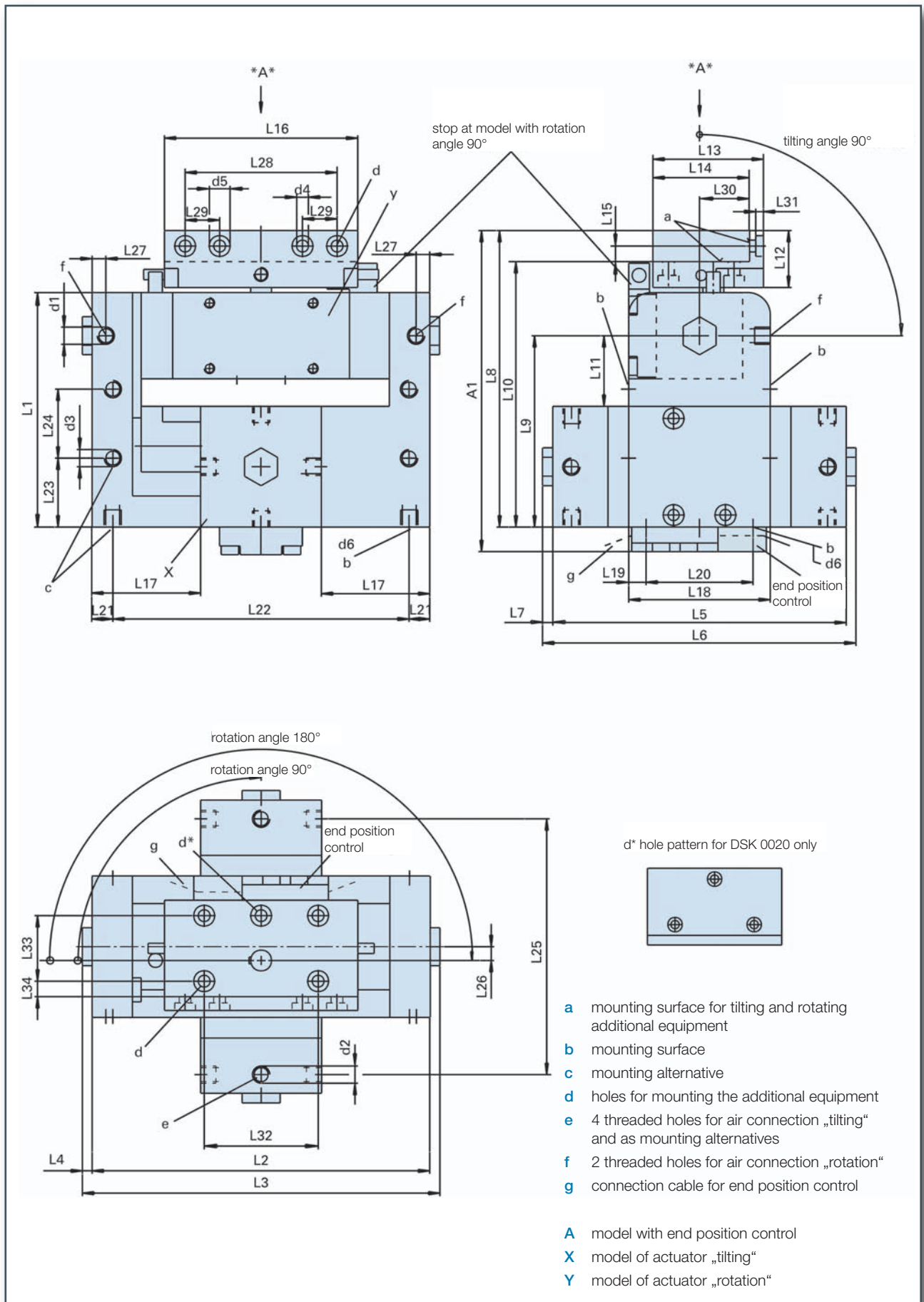

model	DSK 0020	DSK 0050	DSK 0200	DSK 0200
suitable for	PSM 0030-007	PSM 0050-011	PSM 0200-013	PSM 0600-016
X	DA 0050-095	DA 0200-095	DA 0500-095	DA 0500-095
Y	DA 0020-185	DA 0050-185	DA 0200-185	DA 0200-185
d1	M5x8	M5x8	M5x8	M5x8
d2	M5x4	M5x5,5	R1/8x8	R1/8x8
d3	M5x8	M5x8	M6x10	M6x10
d4	6	6	6	8
d5	3,4	3,4	3,4	4,4
d6	M5x8	M5x8	M6x10	M6x10
L1	55	68	99,5	99,5
L2	84 ±0,5	97,8 ±0,5	127 ±0,5	127 ±0,5
L3	--	--	132,6 ±0,7	132,6 ±0,7
L4	--	--	2,8	2,8
L5	70 +0,4-0,6	85 +0,4-0,6	124 +0,4-0,6	124 +0,4-0,6
L6	75,6 +0,6-0,8	90,6 +0,6-0,8	129,6 +0,6-0,8	129,6 +0,6-0,8
L7	2,8	2,8	2,8	2,8
L8	67	86	123,5	129,3
L9	45	55,5	82	82
L10	65	77	114,5	114,5
L11	19	20,5	32	32
L12	10	16,5	22	28
L13	24	32	40	59
L14	22	28	35	54
L15	--	4,5	4,5	7,5
L16	40	56	72	92
L17	29,5	31,4	38,5	38,5
L18	40	41	60	60
L19	5	5	5	5
L20	30	31	50	50
L21	6	6	8	8
L22	72 ±0,7	85,8 ±0,7	111 ±0,8	111 ±0,8
L23	16	20	25	25
L24	16	20	30	30
L25	59,2 ±0,4	74,2 ±0,4	108,2 ±0,4	108,2 ±0,4
L26	2,5	4	6	6
L27	4	4	4,5	4,5
L28	--	44	52	72
L29	--	--	10	15
L30	11	14,5	18	23
L31	4	2,2	3,2	3,2
L32	30	33	65	57
L33	15	19	26	43
L34	3	4,5	4	5,5
A1	75	94	131,5	137,3
"A" kg	4,0	6,0	10,0	10,0
weight in kg	0,4	0,74	1,9	2,0

Ordering Code

DSK XXXX - XXX - X

model code **090** rotation angle max. 90°
180 rotation angle max. 180°

0 = basic model
1 = with end position control (sheet "end position control")
7 = with adapter plate for PSM 0600 instead of PSM 0200
8 = with 1 and 7

we deliver :
Double Tilting Head model DSK 0050
rotation angle max. 90°
with end position control

Ordering Example **you order :**
DSK 0050 - 090 - 1

Swivel Distributor

SLE 1014

Brief technical data

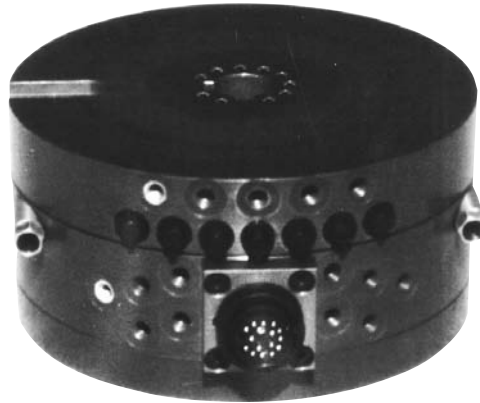

Material:	<ul style="list-style-type: none">- aluminum hard or black anodized- steel parts of stainless material or corrosion resistant- shorttime gas nitration
Operating or mounting position:	<ul style="list-style-type: none">- any position
Operating temperature:	<ul style="list-style-type: none">- -10° to +80° C (14° to 176° F)
Operating pressure:	<ul style="list-style-type: none">- maximum 7 bar
Tilting angle:	<ul style="list-style-type: none">- 90° or 180°- adjustable $\pm 5^\circ$
Swivel distributor:	<ul style="list-style-type: none">- double bearing- friction loss of maximum 40 Ncm- maximum radial load 5000 N- maximum axial load by pushing pressure 2000 N- maximum axial load by pulling pressure 500 N
Pneumatic connections:	<ul style="list-style-type: none">- 10 connections with threaded holes M5 (in)- 10 connections with threaded holes M5 (out)- smallest diameter of air holes is 1,5 mm (0,006 in)
Electronic connections:	<ul style="list-style-type: none">- 14 connections pluggable, 3 lane (out)- 1 connection pluggable, 16 lane (in)- with straight or L-plug- wire cross section 0,14 mm²
Weight:	<ul style="list-style-type: none">- 1,5 kg

[Refer to technical specification sheet on page 53 for dimensions and other details.](#)

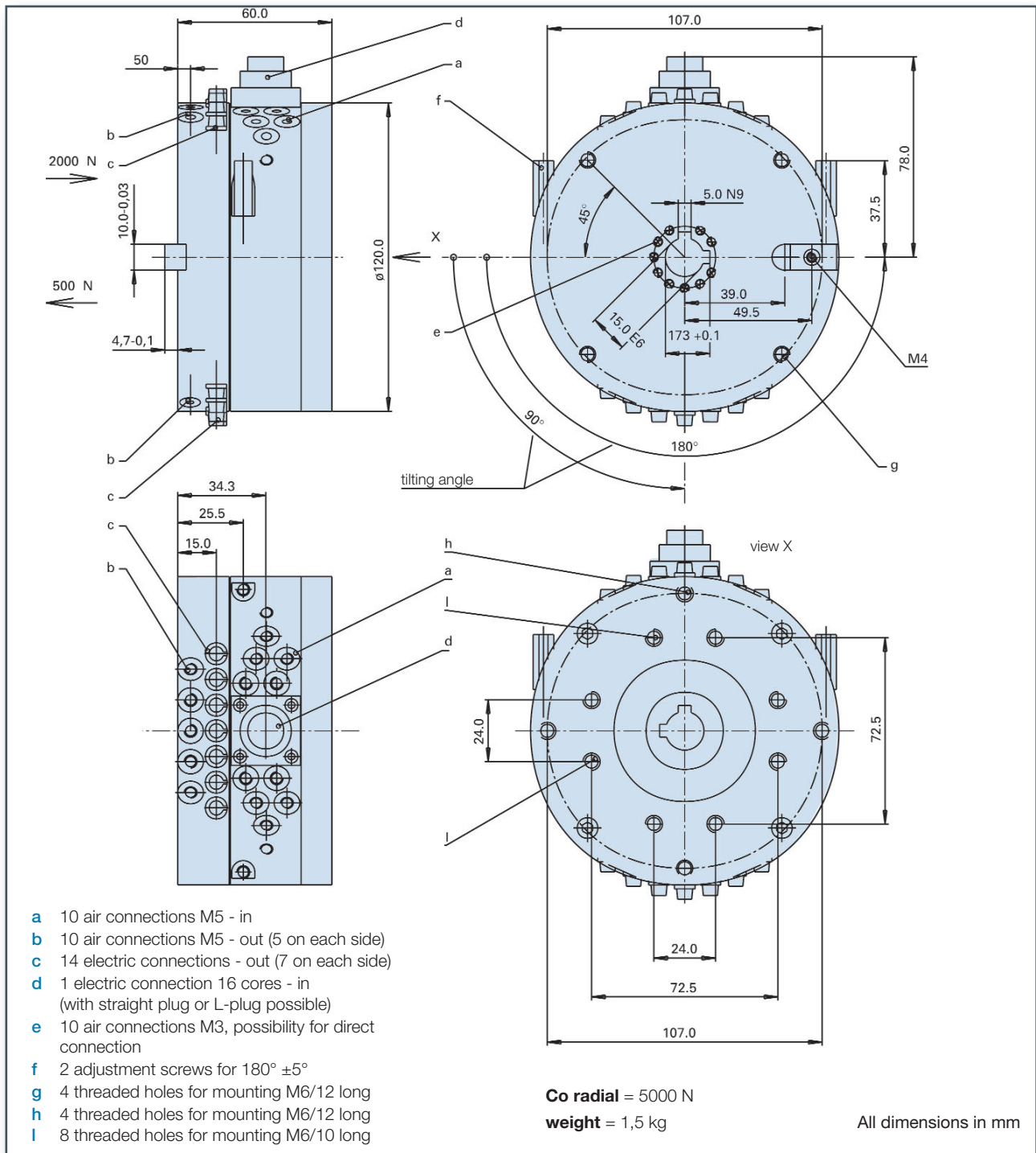

Attachment options with actuators of model DA 0200 – DA 3000 and HPA, information and data sheets on request.

Ordering Code SLE 1014 - XXX - X - X

model code 095 rotation angle max. 95°
 185 rotation angle max. 185°

Ordering Example you order : SLE 1014 - 095 - 0 - 4

0 = basic model
 3 = straight plug
 4 = L-plug

we deliver :
 Swivel Distributor 1014,
 tilting angle max. 95°, basic model,
 with L-plug

Formulas

For selection of the proper PTM-Actuator the following formulas of moment of inertia and gravity may be used:

If you want to calculate the size of the PTM-Actuators theoretically, either the moment of inertia or the rotating time of the moved masses must be known.

In the examples below it is assumed, that the axis of the actuator is vertical. There is no influence of gravity in this position. For other positions the influence of gravity must be considered and will be calculated according to the general formulas.

The moment of inertia of the moved masses can be calculated using the following formulas:

$m = m_1 + m_2 + \dots + m_n$ $J = m_1 \cdot r_1^2 + m_2 \cdot r_2^2 + \dots + m_n \cdot r_n^2$ $J = E (m \cdot r^2)$	$J = \frac{1}{8} m \cdot (d_a^2 + d_i^2)$
$J = \frac{1}{16} m \cdot (d^2 + \frac{4}{3} h^2)$	$J = \frac{1}{12} m \cdot (d^2 + 4b^2)$
$J = \frac{1}{8} m \cdot d^2$	$J = \frac{1}{12} m \cdot (d^2 + b^2)$
$J = \frac{1}{16} m \cdot (d_a^2 + d_i^2 + \frac{4}{3} h^2)$	$J = \frac{1}{10} m \cdot d^2$

General Terms and Conditions of Business

Sales, Delivery and Payment Conditions

of P.T.M. PRODUKTION – Puchheim



1. Scope

These Terms & Conditions of Business shall apply to all contracts, unless they are amended or excluded by our express written permission.

2. Offer and conclusion of contract

An order shall only be deemed accepted when it is confirmed by ourselves in writing. Until that time the offer shall not be binding. Orders, supplementary instructions, amendments etc. given by telephone or telegraph, or verbally, shall not be valid unless they are confirmed in writing by ourselves. The documents contained in our printed material, such as specifications of weights and measures, illustrations and descriptions, shall only be approximate, nor shall there be any obligation to report amendments thereto. Weights, measures, illustrations, designations and drawings shall only be binding in execution if they have been explicitly confirmed in writing. We hereby reserve our objective and intellectual property rights to all illustrations, drawings, sketches and other documents. These must not be duplicated or made accessible to others without our permission and must be returned on demand. The Customer must ensure that the production drawings he provides do not infringe the copyrights of Third Parties. We shall have no duty vis-à-vis the Customer to check whether any copyrights of Third Parties are infringed by the issue of offers based on production drawings which he has sent. Should liability nevertheless transpire on our part, the Customer must indemnify us for any claims of regression. Designs will only be supplied for payment.

3. Prices

Prices will be in EURO, either ex works or ex salesroom, as we deem fit. Packaging, freight, postal charges and insurance are not included in our prices. The same shall apply to part deliveries and express deliveries. Packaging and dispatch will be arranged as we think best, a charge being made for our costs actually incurred, but without obligation on our part. Packaging cannot be taken back. Non-list goods will be subject to a supplement dependent on the special manufacture concerned, and this must be agreed prior to issue of order. Should agreement not be reached, or should it not be possible to set a precise price, a supplement shall be calculated for this based on the actual costs incurred. Our prices are governed by current business conditions and currency arrangements. Should significant amendments in cost accounting prove necessary due to charges for raw and auxiliary materials, to increases in wages or freight charges, or due to amendments thereto, we shall be entitled to adjust said prices. Should a price be raised, the increased price shall be deemed agreed by way of a firm obligation on the part of the Customer.

4. Terms and conditions of payment

Unless agreed otherwise in the written confirmation, payment must be made no later than 30 days following date of invoice, either in cash or by bank transfer, strictly net and excluding any offset or retention. This shall also apply to part deliveries. The commencement of the period of grace for payment shall be governed by the date of invoice. In the case of items specially constructed and manufactured for an order, payment must be in cash, strictly net, all charges paid, one-third payment being made on order, one-third on delivery, and the remainder 30 days following invoice. All receivables due from the Customer shall be payable immediately should he fall into arrears of payment or should he infringe any contractual agreements, including these provisions. This shall also apply to suspension of payments or initiation of a creditors' composition or of bankruptcy proceedings on the part of the Customer. We shall be entitled to require security against our receivables at any time. We shall have no obligation to accept cheques or bills of exchange. Should we accept them, the debt concerned shall be repaid only when they are cashed. The Customer must pay the discount fee, the charges and all costs, whether in or out of court, associated with collection of cheques or bills of exchange. Should payments be deferred or be made later than agreed, we shall be entitled to charge interest amounting to 6% above the discount rate of the Deutsche Bundesbank, without any particular arrears procedure, while reserving the right to claim further damages. Deliveries to firms unknown to us will be made only in return for prior payment or cash on delivery as a condition with declared value. Specially produced items will only be supplied to such firms in return for a payment on account, such payment on account being subtracted from the residual payment.

5. Delivery

All delivery times will be set after careful consultation and agreement. However, they shall not be legally binding. If delivery times are to be met, the Customer must fulfil his contractual duty. Delivery time shall have been met if, prior to its expiry, the item for delivery has left the works, or we have declared ourselves ready and willing to dispatch it. Delivery time shall be extended appropriately should unforeseen circumstances transpire which are beyond our control (e.g. disruption of business, lockouts, delays to supply of raw materials etc.). We shall inform the Customer of the beginning and end of such disturbances as far as we are able. The Customer cannot reject part deliveries. We shall be entitled to make part deliveries at the Customer's expense. Should we discover after conclusion of contract that the Customer is in financial difficulties, we may require security for counter-performance or declare that we shall not undertake performance. In the latter case, the Customer must pay all expenses incurred to date and pay damages for non-execution of delivery. Should we fall into arrears through gross negligence, the Customer may claim damages in compensation amounting to a maximum of 0.5 percent of the price of the delayed delivery for each full week of arrears. All other claims for damages are hereby excluded.

6. Transfer of risk

Once material has been handed over to an agent outside our business or freight carrier, or as soon as it has been dispatched from our works, risk shall be transferred to the Customer, even if carriage-paid delivery has been agreed. We shall only replace goods lost or damaged in transit on the basis of a new order, whereby we shall charge our prices as valid from time to time.

Any discrepancies in the dispatch note or invoice must be reported in writing immediately after reception of goods. We shall only take out transport insurance if the Customer so instructs us, and at his expense. Should dispatch be delayed through fault of the Customer, risk shall be transferred to the Customer from the day when we were ready and willing to make dispatch. In such cases we shall be entitled to effect insurance against all likely risks at the Customer's expense.

7. Liability for defects

Defective deliveries shall be replaced free of charge within the statutory period of limitation. We give a guarantee for a period of one year, beginning on the day of delivery. The Customer must give us an opportunity to confirm that complaints are justified, by inspecting the items concerned. We shall accept no liability for parts which have suffered premature obsolescence because of the nature of their materials or because of the way they have been used; nor damage due to natural wear and tear, inappropriate or careless handling, excessive stress and strain, unsuitable operating resources, chemical or electrical effects, meteorological or other natural influences. In the case of products sent in for finishing, refurbishment or alteration – even those of our own manufacture – we accept no liability for their behaviour under hardening or processing. Should the material become damaged under processing, we shall be paid a corresponding part of the agreed price. In the case of specially produced goods, we shall be liable for culpable defective construction or imperfect execution and for defective materials only if we have provided them and only insofar as we ought to have identified the defect when applying professional care. In the case of manufacture in accordance with a Customer's drawing, we shall be liable only for execution in accordance with drawing. Should we be commissioned with the solution of structural tasks, liability for defects can only be claimed if the Customer can prove that the product culpably fails to correspond to the current state of technology. The Customer can only require, on grounds of liability for defect, that unusable parts be repaired, or that a new delivery be made thereof, as we think fit. In all the aforesaid cases, any other claims by the Customer, of whatever kind, particularly by way of rescission, diminution or compensation, including payment of consequential damages, is hereby excluded. However, the Customer may require rescission or diminution, as he thinks fit, if a replacement delivery or repair is impossible or defective, has been culpably delayed by ourselves, or unjustly refused. The Customer shall pay all costs arising from unjustified complaints. Liability for defect shall cease if the Customer or a Third Party have undertaken repairs without our permission.

8. Proviso of ownership

The item under delivery shall remain our property until all receivables, including future receivables, arising from business relations with the Customer have been paid. This shall apply even if individual receivables, or all receivables, are included in a current account and the balance is struck and recognised. Assertion of such proviso of ownership shall not signify withdrawal from contract. If an item of our goods is combined by the Customer with other products to create a uniform article, it is hereby agreed that the Customer transfer to us joint proportional ownership thereof as set out in Section 947, Paragraph 1 of the Civil Code and jointly maintain the article for us. The Customer shall be entitled to resell the article in the course of normal business. However, he must assert our proviso of ownership vis-à-vis the buyer. He cedes to us here and now all claims which may accrue to him from the buyer from such resale. The Customer shall remain entitled to collect these receivables even after cession. Our right to collect such receivables ourselves shall not be affected thereby; however, we hereby agree not to collect such receivables as long as the Customer fulfils his duties of payment in a due and proper way. All proceeds due to the seller from such cession must be transferred to us immediately after receipt in each case. We may require the Customer, if necessary, to name to us the debtors owing such ceded receivables and to inform said debtors of this cession. Should the article delivered be resold together with other goods not belonging to us, the Customer's receivable due from the buyer shall be deemed to be ceded to the amount of the delivery price agreed between ourselves and the Customer. The Customer must inform us immediately of any attachments by Third Parties upon goods supplied under proviso of ownership or upon ceded receivables. This right of ownership shall also apply vis-à-vis the carrier to whom the goods are entrusted by application of the Customer or at our instance. This proviso of ownership shall be limited inasmuch as ownership of goods supplied shall be immediately transferred to the buyer, and the buyer be entitled to all ceded receivables, as soon as he has paid the receivables for which he is liable to ourselves. Should the value of the securities accruing to the seller exceed total receivables due from the buyer by more than 30 percent, the seller shall have a duty, should the buyer so require, insofar to release such securities as he sees fit. The Buyer's right to ownership of goods under proviso shall cease should he fail to fulfil his duties under this or any other contract. The seller shall then be entitled to take possession of such goods under proviso himself and, irrespective of the buyer's duties of payment, or other duties, towards the seller, to realise their value as best he can by a sale at market rates or by way of auction. The proceeds of such realisation will be offset against the buyer's liabilities, following deduction of costs. Any surplus shall be paid to him.

9. Place of fulfilment and jurisdiction

The works shall be the place of fulfilment for all obligations due by both Parties under this contract. The place of fulfilment for payment shall be Munich. Munich shall be the sole place of jurisdiction for all legal disputes, including any disputes involving procedures for bills of exchange or cheques. However, we may also sue the Customer before the courts of his general place of jurisdiction. Only German law shall apply between the contracting parties. Should one or more of these contractual conditions be ineffective or invalid, the validity of the others shall not be affected thereby.

10. Customer's conditions of purchase

Should the Customer's conditions of purchase conflict with these Terms and Conditions, they shall not be binding on us, even if the Customer has made them basic conditions and we have not explicitly protested.

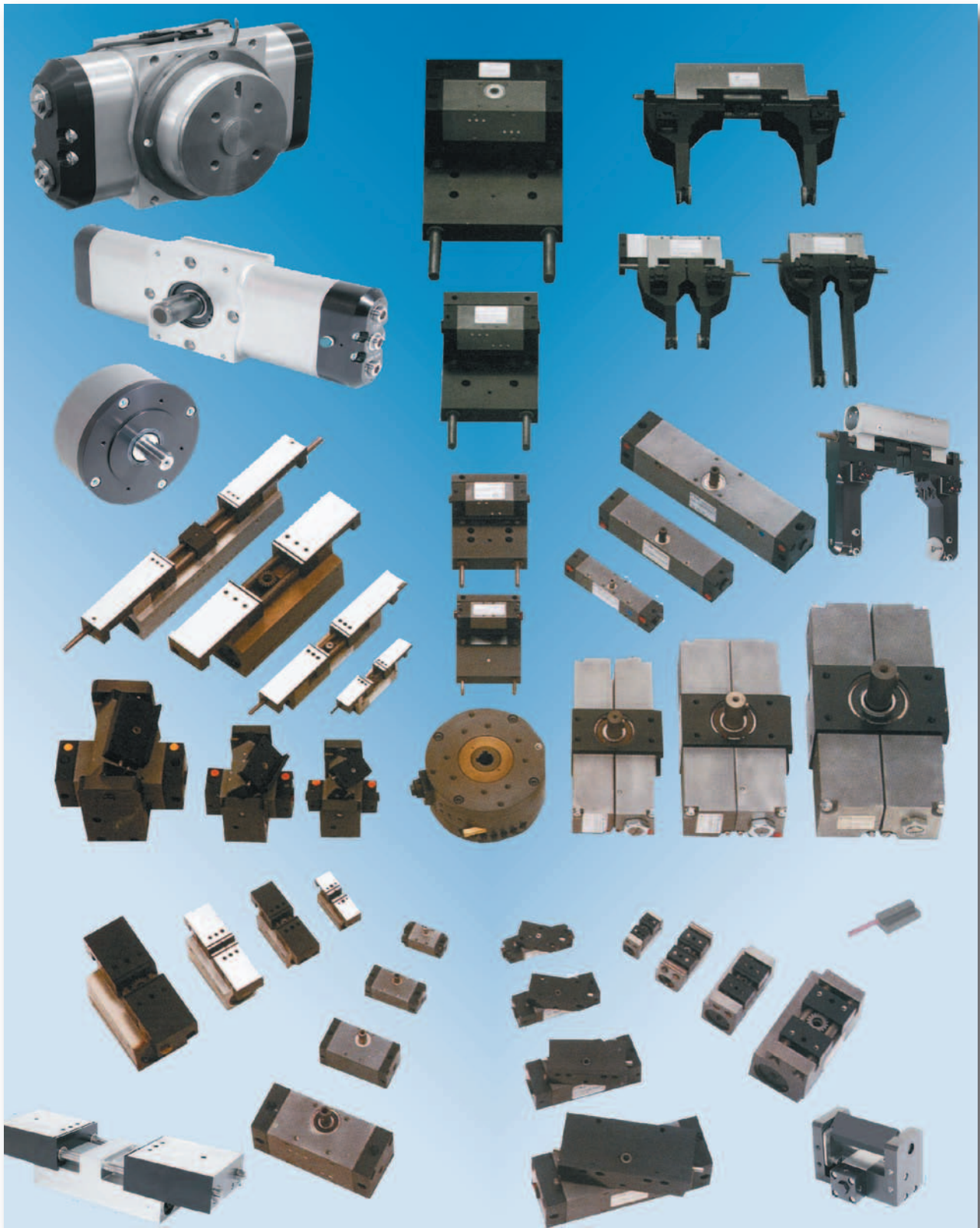

P.T.M. – PRODUKTION tech. -mech. Geräte GmbH
Boschstraße 4 · 82178 PUCHHEIM
Fon +49-(0)89-8002151 · Fax +49-(0)89-8002952
E-Mail: ptm@ptm-produktion.de
Internet: www.ptmgmbh.com