

KRACHT

*A successful future
through experience,
knowledge and technology*

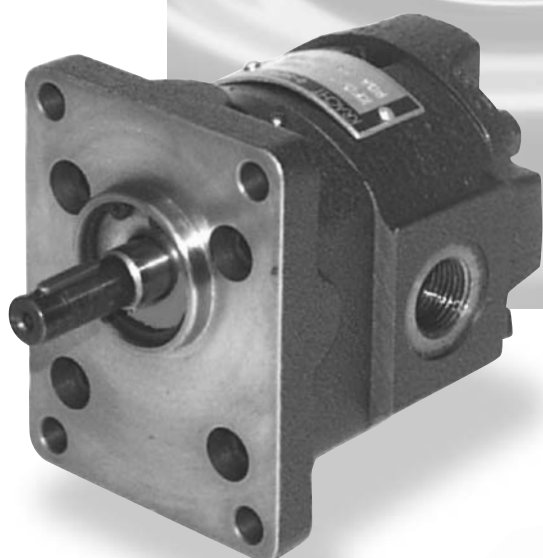

Gear Pumps KF 0

**Gear Pumps KF 0
with magnetic coupling**

Contents

Contents	2
Function KF 0	3
General characteristics	3
Operating characteristics	3
Materials	3
Characteristics	4
Flange pump	5
Type code KF 0	6 – 8
Function KF 0 with magnetic coupling	9
General characteristics	9
Operating characteristics	9
Pump materials	9
Magnetic coupling materials	9
Magnetic coupling torques	9
Selection help	10
Type code KF 0 with magnetic coupling	11

Gear Pumps KF 0

Function

KF 0 – A pump for process engineering.

In numerous technical processes dosing liquids is the focus of the task. PUR components, softeners, resins, lacquers, paints are just some of the most important liquids with a broad application range.

The accuracy, evenness and reproducibility with which these products can be processed are also decisive for the quality of the final product.

The KRACHT gear pump size KF 0 is especially suitable for these applications.

The KF 0 is an external gear pump with flow rates of 0.5 cm³/r to 4 cm³/r.

The grading of the total of 8 nominal sizes makes it easier to set the desired dosing ratios. The fine gearing with a high number of teeth guarantees a low-pulsation volume flow.

All gear parts and the bearing bushes are protected even in the standard design by a special coating against wear and corrosion, so that even filled media up to a specific grain size and hardness of the filled material can be conveyed. Because of the backlash dimensioning in combination with precise production the KF 0 has very good volumetric efficiency over a wide pressure range.

Various types of seals, such as rotary shaft seals and double rotary shaft seals can be selected depending on the task, whereby the latter version enables operations with a water seal (quench) to prevent the pumping medium from hardening or crystallising.

In combination with a KRACHT gear volume meter and the KRACHT evaluation electronics the KF 0 can be extended to a highly precise dosing unit.

General characteristics

Fixing type	Flange fixing
Pipe connection	Threaded connection
Direction of rotation	Clockwise or anticlockwise
Installation location	Any, see dimensional drawings
Weight	2.2 kg

Operating characteristics

Capacity	$V_g = 0.5/0.8/1/1.6/2/2.5/3/4 \text{ cm}^3/\text{r}$
Operating pressure	Suction side $p_{e \text{ min}} = -0.4 \text{ bar}$ (-0.6 bar briefly for starting status) $p_{e \text{ max}} = 2 \text{ bar}$ Pressure side $p_{n \text{ max}} = 120 \text{ bar}$ (depending on the pumping medium, viscosity and pumping volume)
Speed	$n = \dots 3000 \text{ min}^{-1}$ (depending on viscosity)
Viscosity	$v_{\text{min}} = 10 \text{ mm}^2/\text{s}$ $v_{\text{max}} = 20\,000 \text{ mm}^2/\text{s}$
Media temperature	$\vartheta_{m \text{ max}} = 90^\circ\text{C NBR}$ 150°C FKM 200°C PTFE (rotary shaft seal)
Ambient temperature	$\vartheta_{u \text{ min}} = -20^\circ\text{C}$ $\vartheta_{u \text{ max}} = +60^\circ\text{C}$

Materials

Pump housing	GG 30, DIN 1691
Gearing	Steel 1.7139 chemically nickel plated with SiC inclusions
Bearing bushes	Steel ETG 100 chemically nickel plated with SiC inclusions
Seals	NBR, FKM, PTFE

Gear Pumps KF 0

Characteristics max. permissible operating pressure in dependence on viscosity

Nominal size	Permissible operating pressure in bar for viscosity			
	10 mm ² /s	30 mm ² /s	100 mm ² /s	> 500 mm ² /s
0.5	10	30	50	60
0.8	15	40	60	70
1	15	40	60	70
1.6	20	60	80	100
2	20	60	80	100
2.5	30	60	100	120
3	30	60	100	120
4	40	80	120	120

The values are valid for the speed range $n = 1000 \dots 3000 \text{ min}^{-1}$.

Then max. operating pressures must be reduced for speeds $< 1000 \text{ min}^{-1}$

Drive capacity and rate of flow

With speed $n = 1450 \text{ min}^{-1}$ and viscosity $34 \text{ mm}^2/\text{s}$

	Pressure in bar								Nominal size	Pressure in bar								Drive capacity P in kW
	5	10	20	40	60	80	100	120		5	10	20	40	60	80	100	120	
	Rate of flow Q in l/min	0.7	0.6	0.5	-	-	-	-		-	0.5	0.06	0.07	0.09	-	-	-	
	1.1	1.1	1.0	0.8	-	-	-	-	0.8	0.06	0.08	0.11	0.17	-	-	-	-	
	1.4	1.3	1.3	1.1	-	-	-	-	1	0.07	0.08	0.12	0.19	-	-	-	-	
	2.2	2.2	2.0	1.8	1.5	-	-	-	1.6	0.08	0.12	0.18	0.31	0.45	-	-	-	
	2.8	2.7	2.6	2.3	2.0	-	-	-	2	0.09	0.13	0.20	0.35	0.50	-	-	-	
	3.5	3.4	3.3	3.0	2.7	-	-	-	2.5	0.09	0.14	0.22	0.39	0.55	-	-	-	
	4.2	4.2	4.0	3.7	3.5	-	-	-	3	0.10	0.15	0.24	0.42	0.60	-	-	-	
	5.6	5.5	5.4	5.0	4.7	4.3	-	-	4	0.12	0.17	0.29	0.53	0.76	0.99	-	-	

With speed $n = 1450 \text{ min}^{-1}$ and viscosity $120 \text{ mm}^2/\text{s}$

	Pressure in bar								Nominal size	Pressure in bar								Drive capacity P in kW
	5	10	20	40	60	80	100	120		5	10	20	40	60	80	100	120	
	Rate of flow Q in l/min	0.7	0.7	0.6	0.5	-	-	-		-	0.5	0.06	0.07	0.09	0.12	-	-	
	1.1	1.1	1.1	1.0	0.9	-	-	-	0.8	0.06	0.08	0.10	0.16	0.21	-	-	-	
	1.4	1.4	1.4	1.3	1.2	-	-	-	1	0.08	0.09	0.12	0.17	0.23	-	-	-	
	2.3	2.2	2.2	2.1	2.0	1.8	-	-	1.6	0.08	0.11	0.16	0.27	0.38	0.50	-	-	
	2.8	2.8	2.8	2.7	2.6	2.5	-	-	2	0.09	0.12	0.20	0.34	0.49	0.64	-	-	
	3.5	3.5	3.4	3.3	3.2	3.0	2.9	-	2.5	0.09	0.14	0.22	0.38	0.55	0.71	0.88	-	
	4.2	4.2	4.2	4.1	3.9	3.8	3.7	-	3	0.10	0.15	0.24	0.43	0.61	0.80	0.98	-	
	5.7	5.6	5.6	5.5	5.3	5.2	5.0	4.9	4	0.12	0.17	0.29	0.53	0.76	0.99	1.23	1.46	

Gear Pumps KF 0

Flange pump with rotary shaft seal

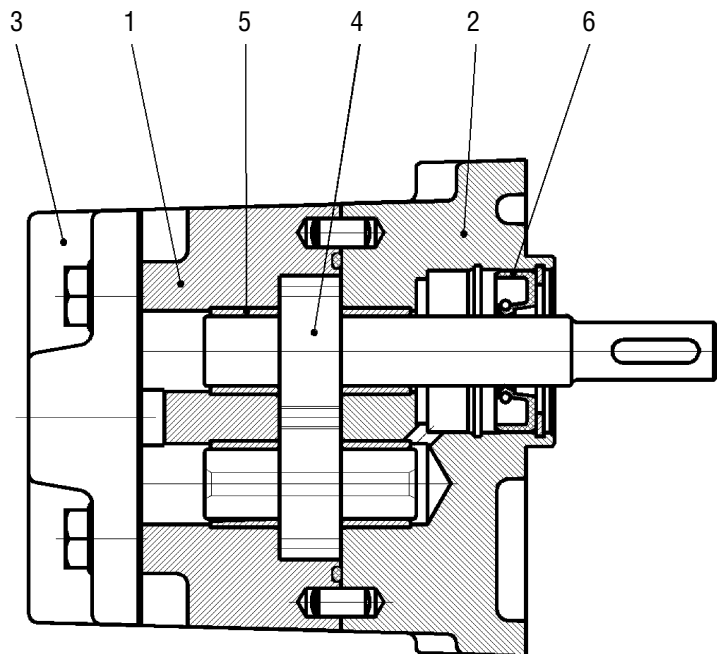

- 1 Housing
- 2 Flange cover
- 3 Cover plate
- 4 Gearing
- 5 Bearing bush
- 6 Rotary shaft seal

Flange pump with double rotary shaft seal and threaded connection for water seal

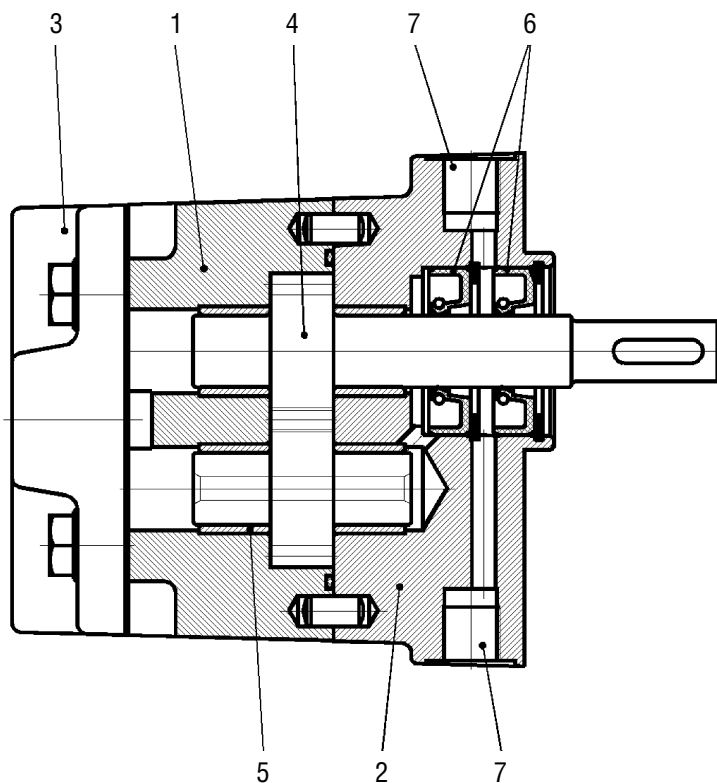

- 1 Housing
- 2 Flange cover
- 3 Cover plate
- 4 Gearing
- 5 Bearing bush
- 6 Rotary shaft seal
- 7 Connection for sealing liquid

Gear Pumps KF 0

Type code

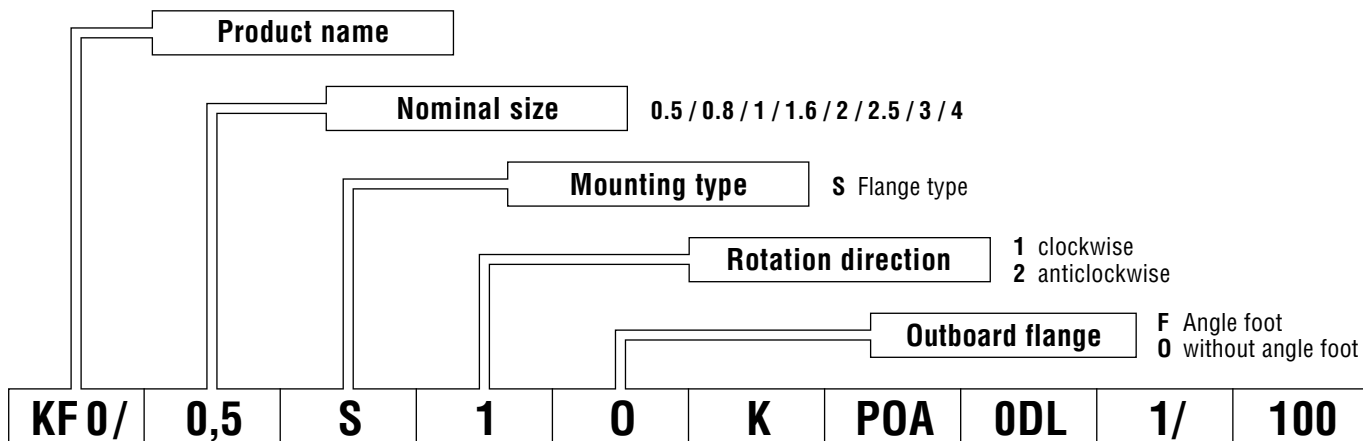

Ordering code:

Type of connection
K Pipe thread
P Cylindrical shaft end
O without 2nd shaft end
A Cover plate

Seal
1 NBR
2 FKM
32 PTFE

Special number
100 Standard
107 With double rotary shaft seal
 Quench connection top and bottom
133 With double rotary shaft seal
 Quench connection at side

0 Design code number
D Housing material GG
L Gearing design: spur toothed

KF 0 / . S . OK POA ODL . / 100

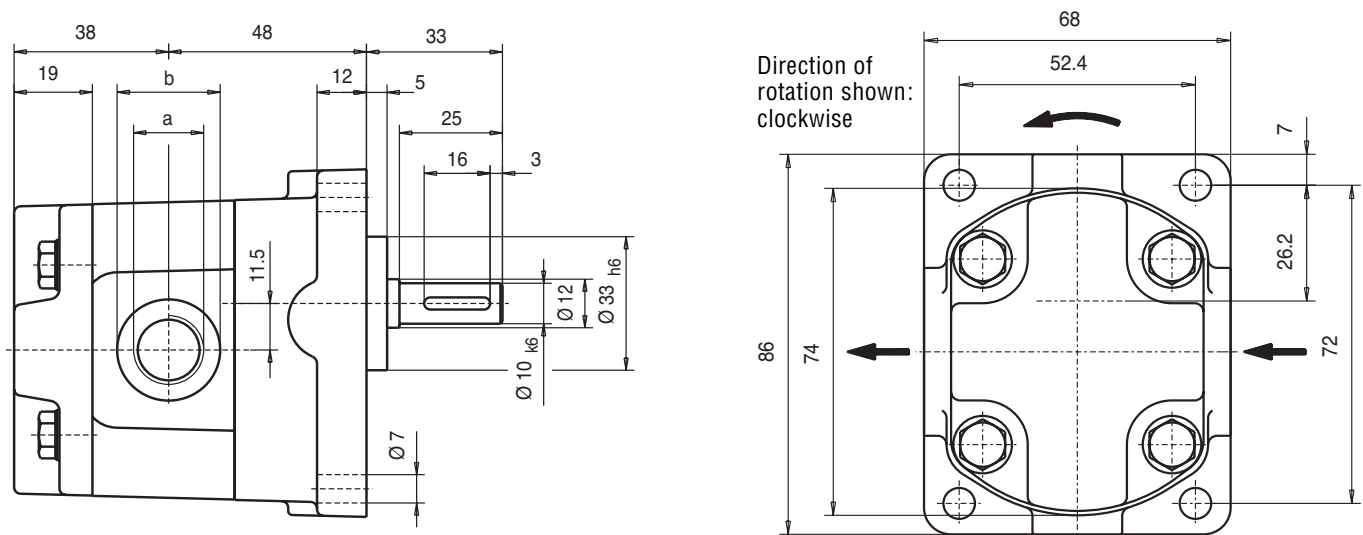

Suction and pressure connection are the same size

Feather key
 A 3 x 3 x 16
 DIN 6885

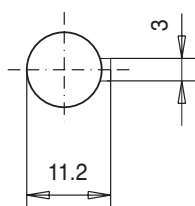

Vg cm ³ /r	Flow volume / nominal size							
	0.5	0,8	1	1.6	2	2.5	3	4
a	G 3/8 - 13 deep			G 1/2 - 15 deep				
b	25			29				

KF0/.S.OK POA ODL./107

Direction of rotation shown: clockwise

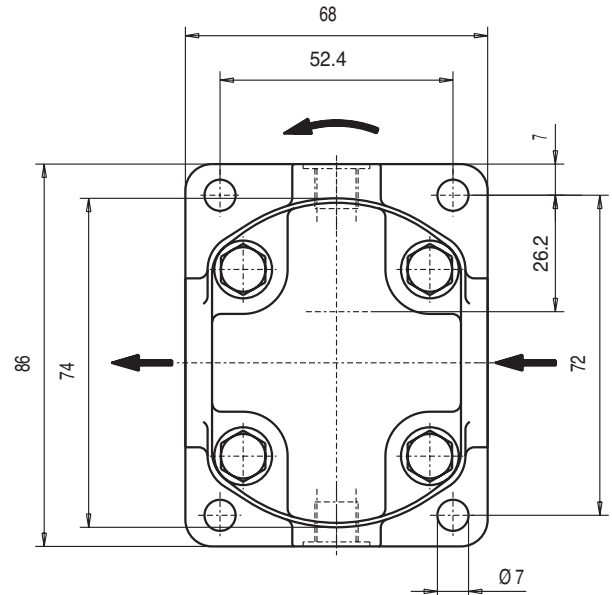
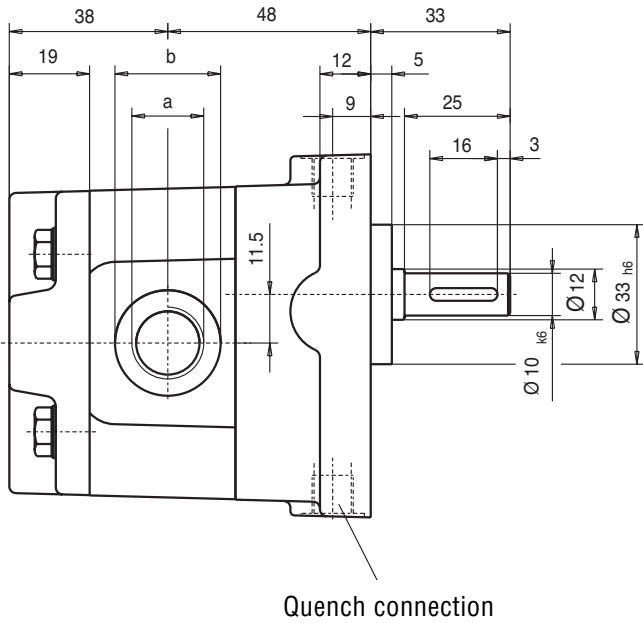

Installation location: quench connection

Suction and pressure connection are the same size

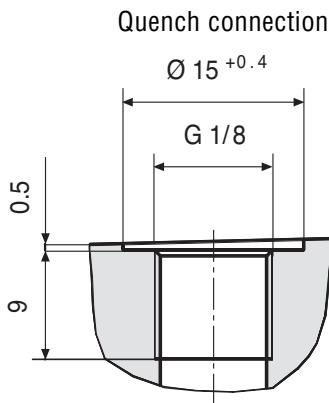

Feather key
A 3 x 3 x 16
DIN 6885

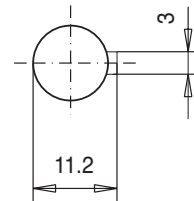

Vg cm ³ /r	Flow volume / nominal size							
	0.5	0.8	1	1.6	2	2.5	3	4
a	G 3/8 - 13 deep			G 1/2 - 15 deep				
b	25			29				

KF0/.S.OK POA ODL./133

Direction of rotation shown: clockwise

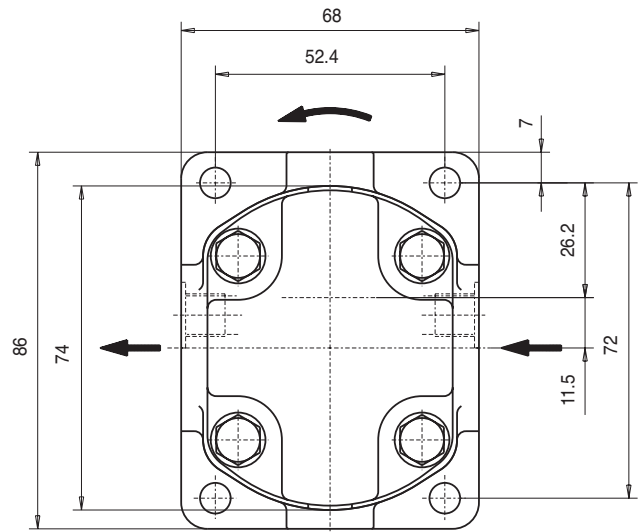
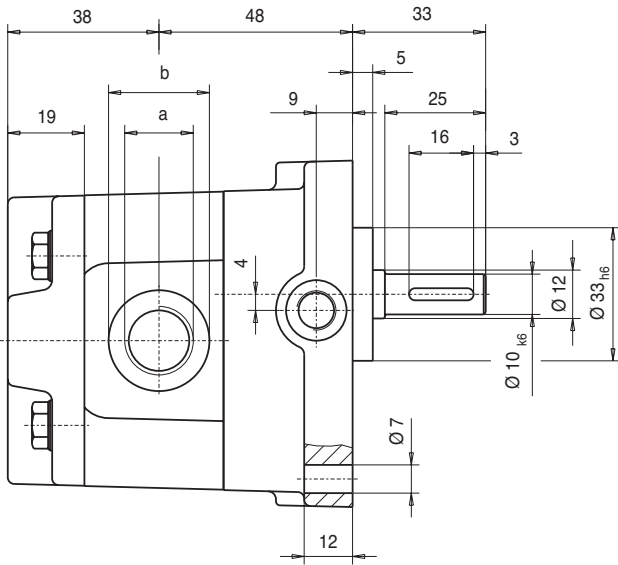

Suction and pressure connection are the same size

Quench connection

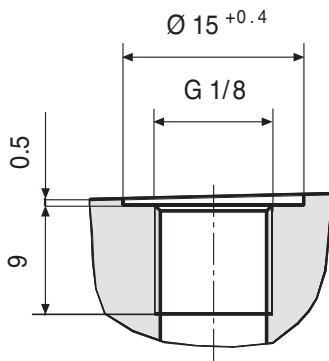

Feather key
A 3 x 3 x 16
DIN 6885

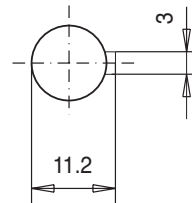

Vg cm ³ /r	Flow volume / nominal size							
	0.5	0.8	1	1.6	2	2.5	3	4
a	G 3/8 - 13 deep			G 1/2 - 15 deep				
b	25			29				

Gear Pumps KF 0 with magnetic coupling

Function

With various applications conventional seals come up against their limits. Typical applications can be found in PUR plants, refrigerating installations and vacuum plant. It is possible to fit the KF 0 with a magnetic coupling for these applications.

The magnetic coupling serves as a shaft seal and to transmit the torque. The outer rotor of the magnetic coupling is placed on the motor shaft and the inner rotor directly on the pump shaft. The torque is transmitted between the outer and inner rotors through the magnetic forces. The split case, which seals the pump hermetically, is located between the two rotors.

The magnetic coupling is used if an absolutely tight seal is required between the pump chamber and the atmosphere, e.g. for dosing isocyanate, where contact with the air would lead to an undesired hardening of the medium. It can be used in vacuum operations, e.g. filling brake liquid, and reliably prevents air penetrating into the system. Non-leak operations are also guaranteed when used in sealed systems with a high admission pressure on the pump suction side. The magnetic coupling is predestined for dosing hazardous and harmful media.

General characteristics

Fixing type	Flange fixing
Pipe connection	Threaded connection
Direction of rotation	Clockwise or anticlockwise
Installation location	Any, see dimensional drawings

Operating characteristics

Capacity	$V_g = 0.5/0.8/1/1.6/2/2.5/3/4 \text{ cm}^3/\text{r}$
Operating pressure	Suction side Operating $p_{e \text{ min}} = -0.4 \text{ bar}$, Vacuum plant -0.92 $p_{e \text{ max}} = 16 \text{ bar (SS1)}$ Standstill $p_{e \text{ min}} = -1 \text{ bar}$ $p_{e \text{ max}} = 16 \text{ bar (SS1)}$ Pressure side $p_{n \text{ max}} = 25 \text{ bar (SS1)}$
Speed	$n = \dots 3000 \text{ min}^{-1}$ (depending on viscosity)
Viscosity	$v_{\text{min}} = 10 \text{ mm}^2/\text{s}$ $v_{\text{max}} = 20\,000 \text{ mm}^2/\text{s}$
Media temperature	$\vartheta_{\text{min}} = -10 \text{ }^\circ\text{C}$ $\vartheta_{\text{max}} = 150 \text{ }^\circ\text{C (FKM)}$, Magnetic material SmCo
Ambient temperature	$\vartheta_{u \text{ min}} = -20 \text{ }^\circ\text{C}$ $\vartheta_{u \text{ max}} = 60 \text{ }^\circ\text{C}$

Pump materials

Pump housing	GG 30, DIN 1691
Gearing	Steel 1.7139 chemically nickel plated with SiC inclusions
Lagerbuchsen	Stahl ETG 100 chemically nickel plated with SiC inclusions
Dichtungen	FKM

Magnetic coupling materials

Inner rotor	Stainless steel 1.4571
Split case	Stainless steel 1.4571
Outer rotor	355J2G3 (St 52)
Magnets	Sm2Co17

Magnetic coupling torques

MSA 46/6	3 Nm
MSA 60/8	7 Nm
MSB 60/8	14 Nm

Gear Pumps KF 0 with magnetic coupling

Selection help

Pump	Coupling size	Perm. torque [Nm]	Perm. output [kW] at n = 750 1/min	Motor size	Perm. output [kW] at n = 950 1/min	Motor size	Perm. output [kW] at n = 1450 1/min	Motor size
KF 0	MSA 46	3	0.18	80	0.25	71	0.37	71
	MSA 60	7	0.25	80	0.37	80	0.55	80
			0.37	90	0.55		0.75	
	MSB 60	14	0.55	90	0.75	90	1.1	90
			0.75	100	1.1		1.5	

Gear Pumps KF 0 with magnetic coupling

Type code

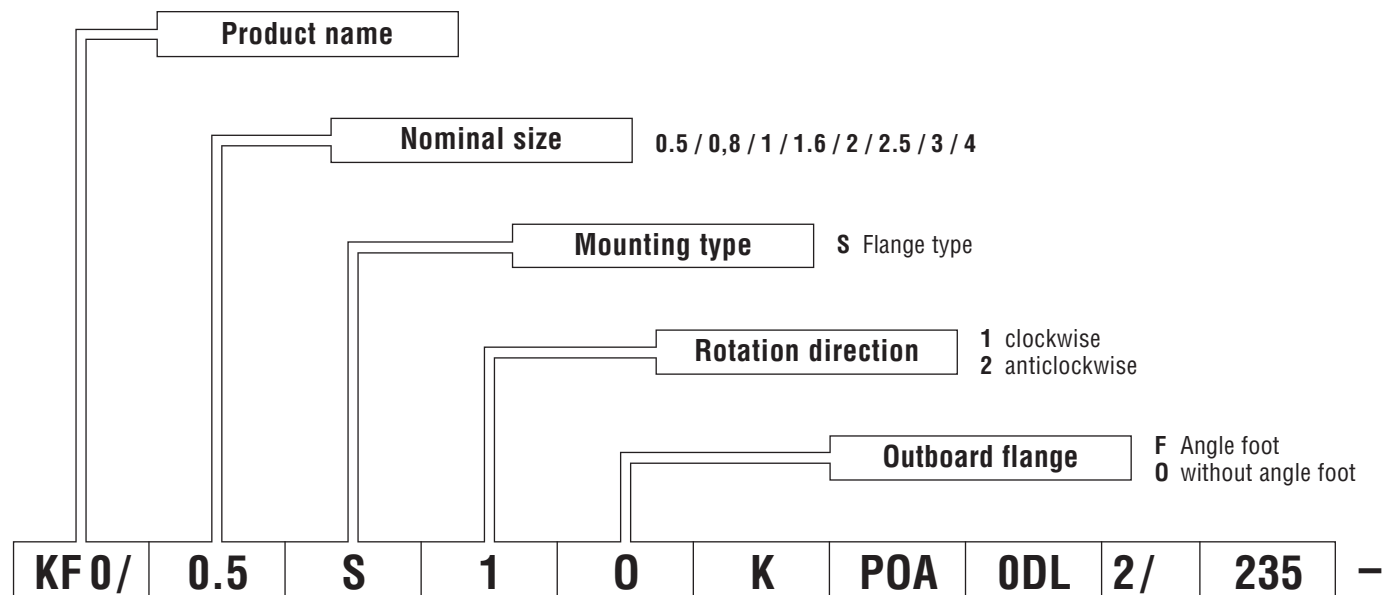

Ordering code:

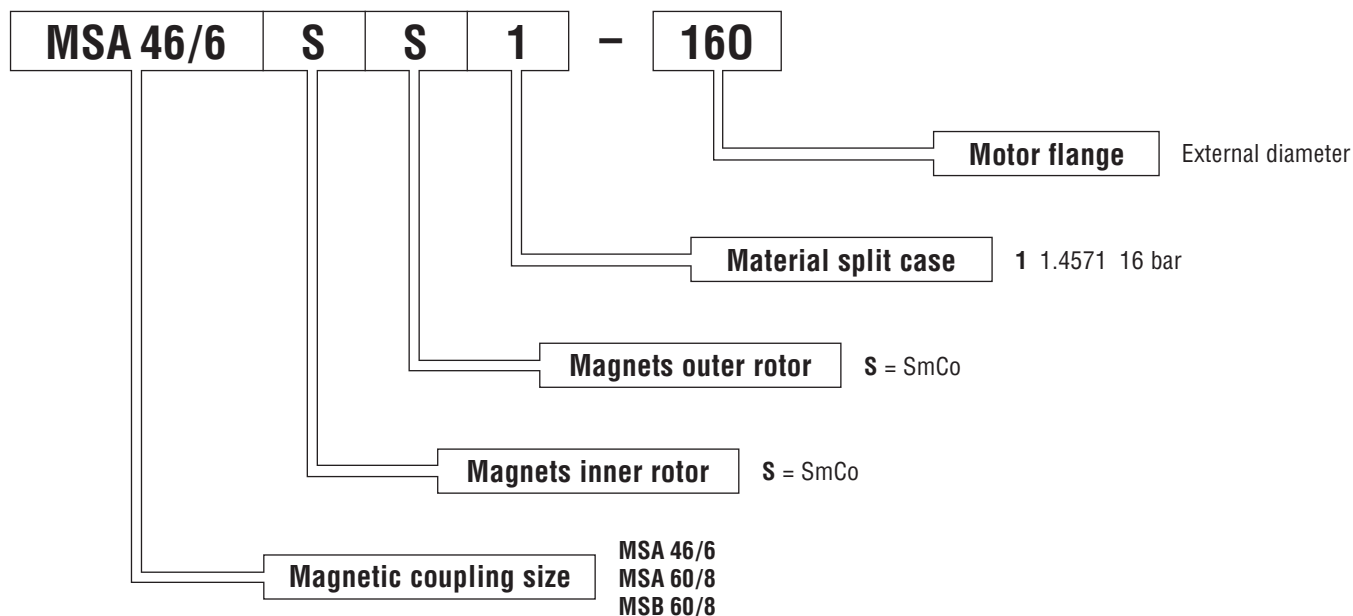
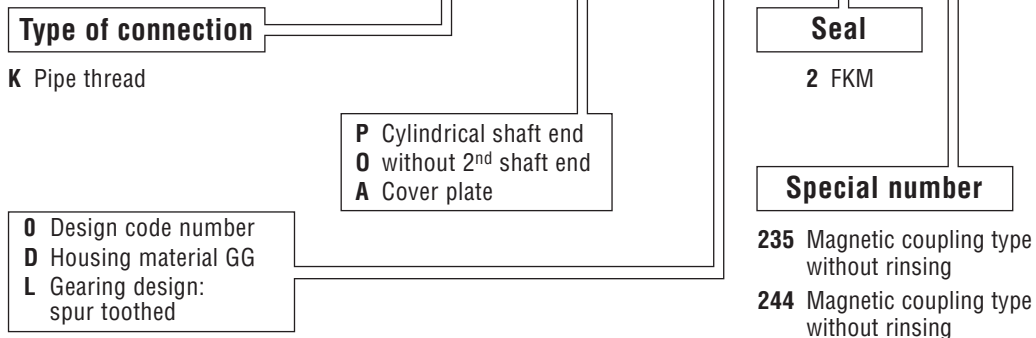

Overview of our complete program

Transfer pumps

Transfer pumps for lubricating oil supply equipment, low pressure filling and feed systems, dosing and mixing systems.

Flow Measurement

Gear and turbine flow meters and electronics for volume and flow metering technology in hydraulics, processing and laquering technology.

Mobile hydraulics

Single and multistage high pressure gear pumps, hydraulic motors and valves for construction machinery, vehicle-mounted machines.

Industrial hydraulics

Cetop directional control and proportional valves, hydraulic cylinders, pressure, quantity and stop valves for pipe and slab construction, hydraulic accessories for industrial hydraulics (mobile and stationary use).

With our decades of experience, we are at your side, world-wide, for the professional mastery of specific applications and complete solutions in hydraulics and process technology.



KF0 - KF0 with magn. coupl./e/07.06