



Air Motors/Gearmotors

Known industry wide for their rugged construction and reliability, Gast Air Motors and air powered Gearmotors are used in a variety of applications.

Lubricated Air Motors come in seven basic models up to 9.5 HP (7.1 kW); motor speeds are variable from 300 to 10,000 RPM. Oilless versions, which require absolutely no lubrication, come in three basic models ranging from .18 to 2.5 HP (0.13 to 1.86 kW) and with motor speeds up to 4,000 RPM. Choose from hub, foot, face, NEMA C-Flange or Metric D Series interface mountings and clockwise, counterclockwise or reversible rotations. Four and eight vane models are also available.

Air powered Gearmotors are available in rightangle and in-line models offering a maximum torque range of 73 to 5,200 lb. in. (8 to 587 Nm) and gear ratios from 10:1 to 60:1 single reduction gear reducers. A full line of recommended accessories is also available.

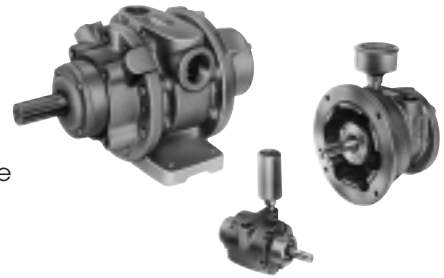

Why you should look into a Gast Air Motor

- **Variable speed.**
You can vary air motor speed between 300 and 10,000 rpm (depending on model selection) with a simple valve put in between the air source and air motor.
- **Nonelectrical sparking.**
As a nonelectrical device, the possibility of explosion from igniting flammable gases is greatly reduced.
- **Instantly reversible.**
A four-way valve in the air line enables a Gast Air Motor to be instantly reversed. A turn of the valve causes a complete reversal of rotation, even when the motor is running at full speed.
- **Cool running.**
As the air motor turns, expanded air cools the motor. Units can be used in ambient temperatures up to 250°F (120°C) in a nonhazardous atmosphere.
- **Compact and portable.**
Get maximum horsepower with minimum size and weight.
- **Minimum maintenance.**
You can put a Gast Air Motor in places where they will not get much service, because there's virtually nothing to service on a Gast Air Motor, providing it is operated on a clean, dry, and lubricated air supply*.
- **Will not burn out.**
Gast Air Motors can be stalled or overloaded for long periods without damage.
- **Low price.**
Cost is less than other motors of equal horsepower and capabilities.
- **Operate in all positions.**
Mount them sideways, upside-down, or in any position so long as adequate lubrication* is provided and end thrust is kept to design limits. Gearmotors will operate in almost any position, see model data.
- **Low-shock starts.**
Because Gast Air Motors go to work with air-cushioned smoothness, they cut stress on your equipment.
- **Self-sealing vanes.**
Vanes are self-sealing and automatically take up their own wear, thus ensuring constant output for thousands of hours of use.
- **Mounting flexibility.**
Foot, hub, face, NEMA-C or metric flange motor mountings are standard equipment for most air motor sizes.
- **Four-vane or eight-vane.**
Four-vane units meet most requirements, but for more precise inching control and minimum blowby in applications where motor is operating in a stalled condition, specify eight-vane models.
- **Long-life accessories.**
To ensure long life, Gast offers accessories designed to extend unit life including air filters that remove water and particles down to 5 microns, and air line lubricators that supply a constant flow of lubrication automatically*. We can supply a pressure regulator that provides precise control of power and operating speed. Options like these help you get smooth performance with minimum maintenance.

*Non-lubricated series does not require a lubricator

Pictorial and dimensional data is subject to change without notice.

The information presented in this catalog is based on technical data and test results of nominal units. It is believed to be accurate and is offered as an aid in the selection of Gast products. It is the user's responsibility to determine suitability of the product for intended use and the user assumes all risk and liability whatsoever in connection therewith.



Typical Applications

- Mixing Equipment
- Conveyor Drives
- Pump Drives
- Food Packaging
- Pharmaceutical Packaging
- Hoists and Winches
- Hose Reels
- Fiberglass Choppers
- Tension Devices
- Turntables

The chart below shows general performance ranges of our lubricated Air Motors. See if we have the right offering for your application.

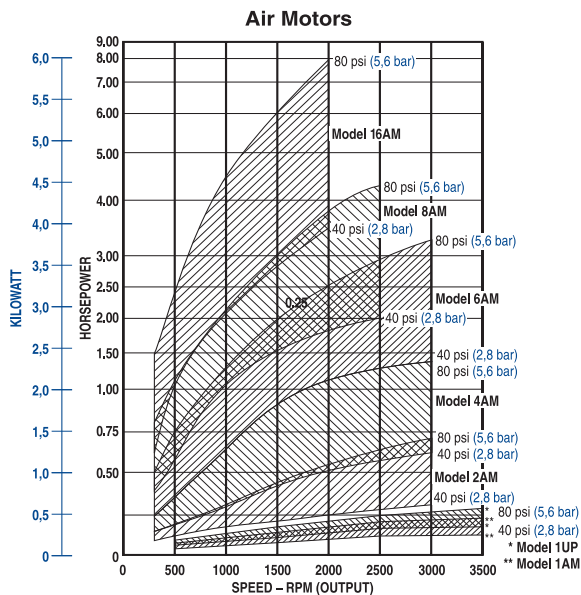

Use of Air Motors in Hazardous Atmospheres

Most of the Gast air motors and some of the gearmotors in this catalog meet the requirements of the EC directive 94/9EC (ATEX 100a). They may be used in zones 1 and 2 where explosive atmospheres of gas or dust are likely to occur. These are marked with II 2 G D c T4 in the catalogue and on the product. This indicates the air motor is Group II, Category 2, Gas and Dust Atmospheres, and a maximum surface temperature of 275°F/ 135°C. Check that the product driven by the air motor meets ATEX directive.

There are several points regarding the safety of air motors. Our air motors are not a source of electric sparks. However, it is possible that an article which is not part of the air motor (e.g., wrenches, hammers, etc.) could create a spark by sharply impacting a cast iron or aluminum case or the steel shaft of the air motor. [Note that electric motor enclosures for both class 1 and II hazardous locations can be made of "...iron, steel, copper, bronze, or aluminum..." (UL 674, Electric Motors and Generators - Hazardous Locations, June 23, 1989; paragraph 4.2, page 6)].

How to select an air motor.

Air motors differ in many ways from other power sources. These unique operating characteristics must be considered when selecting an air motor for a particular job. It is easy to change horsepower and speed of an air motor by throttling the air inlet. Therefore, the best rule of thumb for selecting an air motor is to choose one that will provide the horsepower and torque needed using only two-thirds ($\frac{2}{3}$) of the line pressure available. The full air line pressure will then be available for overloads and starting.



• Output Power vs Speed.

The output power of an air motor is relative to speed and to air line pressure.

• Torque vs Speed.

1. An air motor slows down when load increases... at the same time its torque increases to a point where it matches the load. It will continue to provide increased torque all the way to the stalled condition, and it can maintain the stalled condition without any harm to the motor.
2. As the load is reduced, an air motor will increase speed and the torque will decrease to match the reduced load.
3. When the load on an air motor is either increased or decreased, speed can be controlled by increasing or decreasing air pressure.
4. Starting torque of an air motor is lower than running torque. While this provides smooth, low-shock starting, it is necessary to have additional air line pressure for starting under heavy loads.

• Air Consumption vs Speed.

Air consumption increases as speed and air pressure is increased.

Gast air motors are designed to be operated by compressed air, the expansion of which creates a cooling effect. As a result, the outside surface temperature of the air motor will not reach ignition temperature. A maximum surface temperature of 275°F/135°C. Operation of the air motor with compressed air purges a flammable mixture from the inside of the air motor. **To prevent static electricity from being an ignition source electrically ground the metal air motor.**

We do not guarantee the safety of any application, but to ensure the safe operation of an air motor in your application, always follow the product operation manual, follow ATEX 100a when operating in a hazardous atmosphere and consult with a qualified engineer.



Whatever your rotary air motor power requirements, chances are we have what you're looking for.

Performance Overview

AIR MOTORS

MODEL	OPERATING DATA										Page No.
	MAX. SPEED	MAX OUTPUT POWER		TORQUE AT MAX OUTPUT		MAX. AIR CONSUMPTION		MAX. SPEED	MAX TORQUE		
	rpm	hp	kW	lb. in.	Nm	cfm	m ³ /h	rpm	lb. in.	Nm	
1AM (A)	10,000	0.45	0,33	2.75	0,31	20.5	35,1	650	5.60	0,65	5
1UP (B)	6,000	0.45	0,33	5.25	0,58	27	47	500	6.00	0,68	5
2AM (A)	3,000	0.93	0,68	19.50	2,20	30	49,5	350	26.10	3,05	6-7
4AM (A)	3,000	1.70	1,30	36.00	4,1	78	132,5	300	56.00	6,3	8-9
6AM (A)	3,000	4.00	3,00	84.00	10,00	128	228	300	115.00	13,00	10-11
8AM (A)	2,500	5.25	3,90	132.00	14,40	175	293	300	185.00	21,00	12-13
16AM (A)	2,000	9.50	7,00	290.00	34,00	275	475	300	372.00	43,00	14
*NL22(B)	4,000	.18	0,13	2.80	0,32	18.5	31	1000	4.30	0,49	16
*NL32(B)	2,000	.42	0,31	13.50	1,5	30	51	300	21.00	2,5	17
*NL42(B)	2,000	.82	0,61	25.50	2,90	41	70	500	44.00	5,0	18
*NL52(B)	2,000	2.50	1.86	78.75	8,90	68	115	500	100.00	11,3	19

*Oilless models

GEARMOTORS

MODEL	GEAR RATIO	OPERATING DATA											Page No.
		MAX. SPEED	LINE PRES.	MAX OUTPUT POWER		TORQUE AT MAX OUTPUT		MAX. AIR CONSUMPTION		MAX. SPEED	MAX TORQUE		
		rpm		hp	kW	lb. in.	Nm	cfm	m ³ /h	rpm	lb. in.	Nm	
1AM-NRV	15:1	350	A	0.34	0,26	62	7,1	21.0	36	30	72	8,1	21
1UP-NRV	15:1	400	C	0.32	0,23	49	5,5	21.0	36	30	71	8,0	21
4AM-RV	10:1	300	B	1.26	0,94	274	31,0	57.5	98	30	425	48,0	22
4AM-RV	15:1	200	B	1.25	0,90	400	45,2	60.0	102	20	640	72,0	22
4AM-70C	20:1	150	A	1.17	0,87	487	55,0	71.0	120	15	740	83,6	23
4AM-70C	40:1	75	A	0.95	0,71	800	90,4	71.0	120	7	1255	141,8	24
4AM-70C	60:1	50	A	0.82	0,61	1040	117,5	71.0	120	5	1640	185,3	25
6AM-22A	10:1	300	A	3.40	2,54	720	81,4	130.0	221	30	950	107,4	26
6AM-22A	20:1	150	A	2.65	1,98	1100	124,3	130.0	221	15	1550	175,6	27
6AM-22A	40:1	75	A	2.10	1,57	1725	194,9	135.0	230	8	2500	282,5	28
8AM-32A	20:1	125	A	3.70	2,76	1850	209,1	177.0	301	15	2550	288,2	29
16AM-13	20:1	100	A	6.50	4,85	4175	471,8	275.0	468	15	5175	584,8	30

A – 100 psig and 7,0 bar line pressure for imperial and metric data, respectively.

B – 80 psig and 5,5 bar line pressure for imperial and metric data, respectively.

C – 60 psig and 4,1 bar line pressure for imperial and metric data, respectively.



MODEL

1AM-NCC-12

(4 Vanes, CCW Rotation)

1AM-NCW-14

(4 Vanes, CW Rotation)

1AM-NRV-39A

(4 Vanes, Reversible)

1AM-NRV-63A

(8 Vanes, Reversible)

Net wt. 2 lbs. (0,9 kg)

FEATURES

- Hub mounting
- Any plane operation
- Muffler AF350

- II, 2 GD c T4

RECOMMENDED

- Filter AH100F
- Regulator AH101R
- Gauge AA806
- Lubricator AH102L
- Oil AD220 – 1 quart (.94 liters)
- Repair kit K200 (Single Rotation)
- Repair kit K201 (Reversible)
- Repair kit K278 (8 Vane, Reversible)

OPTIONAL

- Foot mounting- see page 34

1UP-NCC-1A

(4 Vanes, CCW Rotation)

1UP-NCW-2A

(4 Vanes, CW Rotation)

1UP-NRV-3A

(4 Vanes, Reversible)

1UP-NRV-10

(8 Vanes, Reversible)

Net wt. 3 lbs. (1,4 kg)

FEATURES

- Hub mounting
- Any plane operation
- Muffler AF350

- II, 2 GD c T4

RECOMMENDED

- Filter AH100F
- Regulator AH101R
- Gauge AA807
- Lubricator AH102L
- Oil AD220 – 1 quart (.94 liters)
- Repair kit K285 (Single Rotation)
- Repair kit K286 (Reversible)
- Repair kit K298 (8 Vane, Reversible)

OPTIONAL

- Foot mounting-see page 34



inches / mm

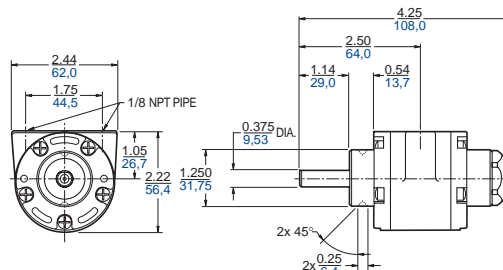

inches / mm

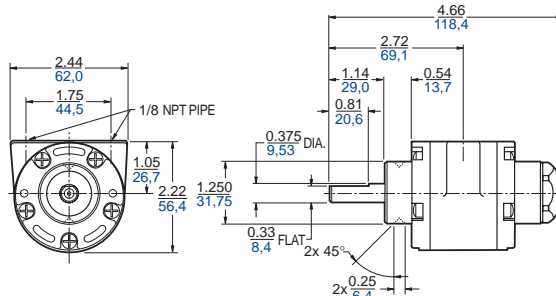

Output Power vs. Speed

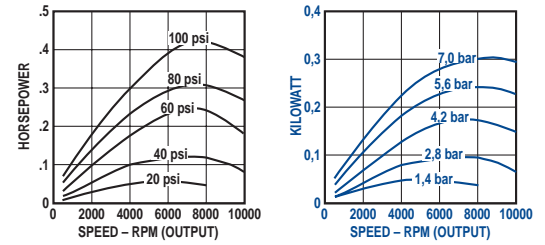

Torque vs. Speed

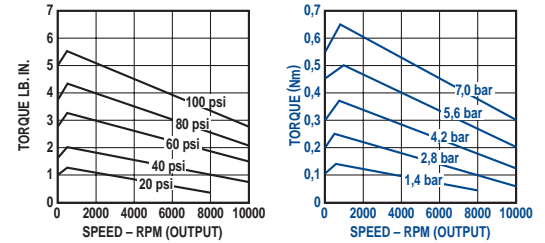

Air Consumption vs. Speed

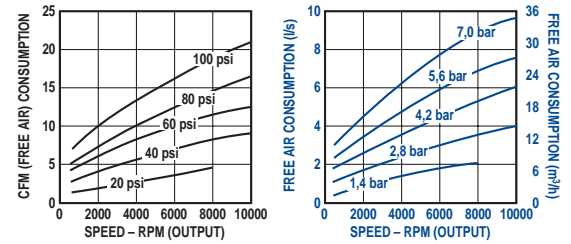

Output Power vs. Speed

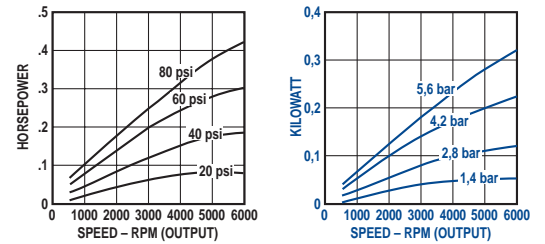

Torque vs. Speed

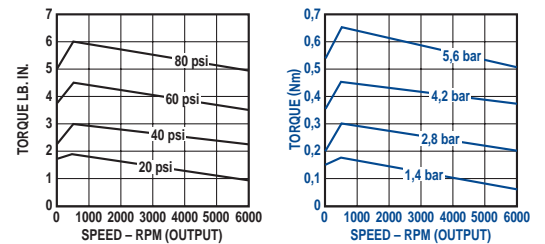

Air Consumption vs. Speed

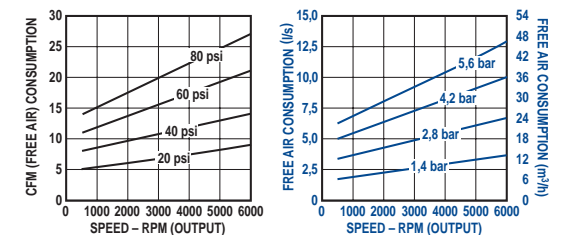



MODEL

2AM-FCC-1

(4 Vanes, CCW Rotation)

2AM-FCW-13

(4 Vanes, CW Rotation)

Net wt. 7 lbs. (3,2 kg)

FEATURES

- Foot mounting
- Any plane operation
- Metal muffler AC980 adds 2" height when installed

- II 2 GD c T4

RECOMMENDED

- Filter AH103F
- Regulator AH104R
- Gauge AA806
- Lubricator AH105L
- Oil AD220 – 1 quart (.94 litres)
- Repair kit K202 (Single Rotation)



inches / mm

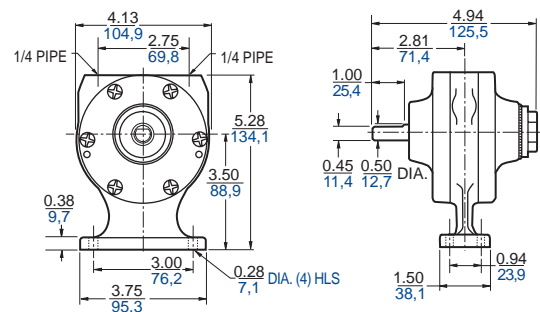

2AM-NCC-16

(4 Vanes, CCW Rotation)

2AM-NCW-7B

(4 Vanes, CW Rotation)

2AM-NRV-89

(4 Vanes, Reversible)

Net wt. 6 lbs. (2,7 kg)

FEATURES

- Hub mounting
- Any plane operation
- Metal muffler AC980 adds 2" height when installed

- II 2 GD c T4

RECOMMENDED

- Filter AH103F
- Regulator AH104R
- Gauge AA806
- Lubricator AH105L
- Oil AD220 – 1 quart (.94 litres)
- Repair kit K202 (Single Rotation)
- Repair kit K509 (Reversible)



inches / mm

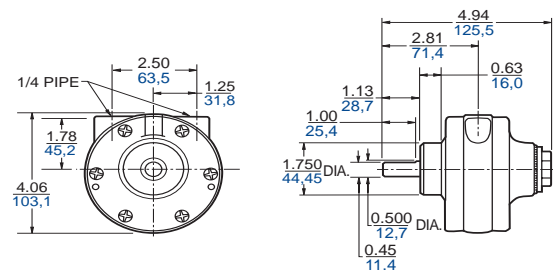

2AM-NCC-43A

(4 Vanes, CCW Rotation)

2AM-NRV-90

(4 Vanes, Reversible)

Net wt. 15 lbs. (6,8 kg)

FEATURES

- NEMA 56C mounting
- Any plane operation
- Metal muffler AC980 adds 2" height when installed

- II 2 GD c T4

RECOMMENDED

- Filter AH103F
- Regulator AH104R
- Gauge AA806
- Lubricator AH105L
- Oil AD220 – 1 quart (.94 litres)
- Repair kit K203A (Single Rotation) • Repair kit K510 (Reversible)



inches / mm

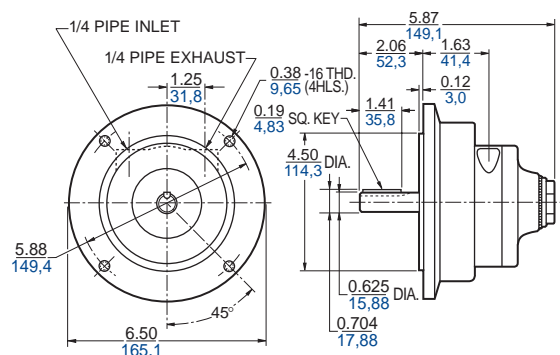

MODEL

2AM-ACC-88

(4 Vanes, CCW Rotation)
Flange Mount

2AM-ACC-91

(4 Vanes, CCW Rotation)
Face Mount

2AM-ARV-92

(4 Vanes, Reversible)
Flange Mount

2AM-ARV-93

(4 Vanes, Reversible)
Face Mount

FEATURES

- IEC #72 mounting frame size:
D71 (2AM-ACC-88, 2AM-ARV-92)
D71C (2AM-ACC-91, 2AM-ARV-93)
- Any plane operation
- Metal muffler AC980 adds 2" height when installed

•  II 2 GD c T4

RECOMMENDED

- Repair kit K203A (Single Rotation)
- Repair kit K510 (Reversible)



Models 2AM-ACC-88/2AM-ARV-92

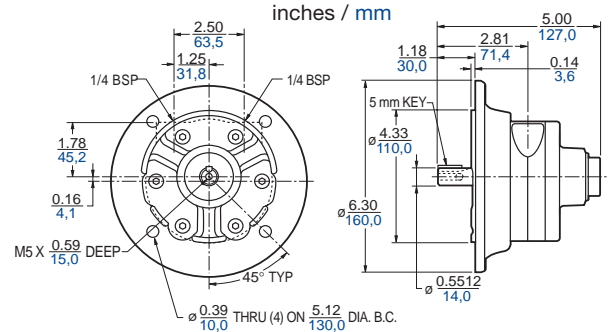

Models 2AM-ACC-91/2AM-ARV-93

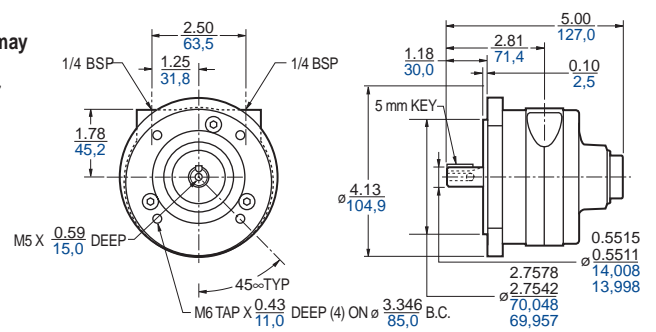

Delivers up to 0,56 kW (¾ hp). Speeds may be varied from 300 to 3,000 rpm. Max. recommended operating pressure 7 bar (100 psi).

Output Power vs. Speed

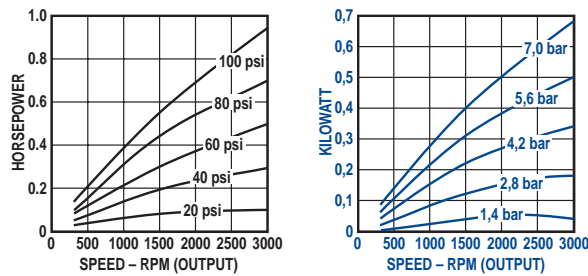

Torque vs. Speed

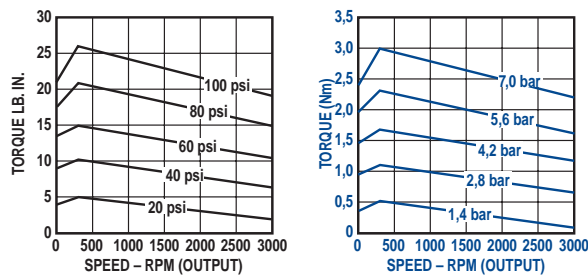

Air Consumption vs. Speed

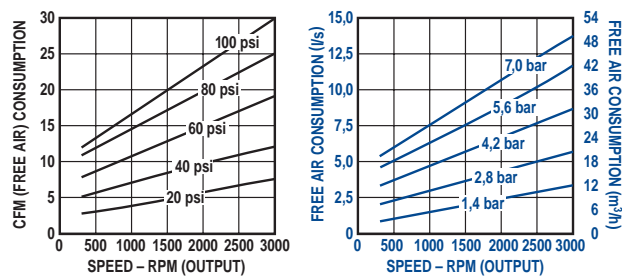



MODEL

4AM-FRV-24

(4 Vanes, Dual Shaft)

4AM-FRV-13C

(4 Vanes, Reversible)

4AM-FRV-63A

(8 Vanes, Reversible)

Net wt. 9 lbs. (4,1 kg)

FEATURES

- Foot mounting
- Any plane operation
- Single or dual shaft
- Metal muffler AC980 adds 2" height when installed.

- II 2 GD c T4

RECOMMENDED

- Filter AH103F
- Regulator AH104R
- Gauge AA806
- Lubricator AH105L
- Oil AD220 – 1 quart (.94 litres)
- Repair kit K205 (4 Vane, Reversible)
- Repair kit K279 (8 Vane, Reversible)

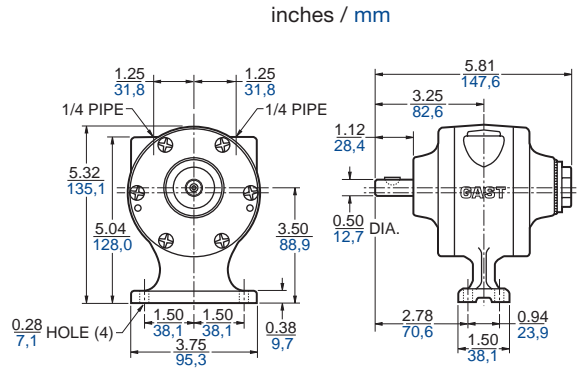

4AM-NRV-22B

(4 Vanes, Reversible)

4AM-NRV-54A

(8 Vanes, Reversible)

Net wt. 9 lbs. (4,1 kg)

FEATURES

- Face mounting
- Any plane operation
- Metal muffler AC980 adds 2" height when installed.

- II 2 GD c T4

RECOMMENDED

- Filter AH103F
- Regulator AH104R
- Gauge AA806
- Lubricator AH105L
- Oil AD220 – 1 quart (.94 litres)
- Repair kit K205 (4 Vane, Reversible)
- Repair kit K279 (8 Vane, Reversible)

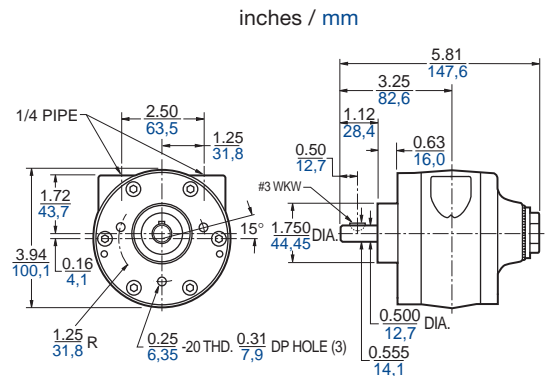

4AM-NRV-50C

(4 Vanes, Reversible)

4AM-NRV-70C

(8 Vanes, Reversible)

Net wt. 12 lbs. (5,4 kg)

FEATURES

- NEMA 56C mounting
- Any plane operation
- Metal muffler AC980 adds 2" height when installed

- II, 2 GD c T4

RECOMMENDED

- Filter AH103F
- Regulator AH104R
- Gauge AA806

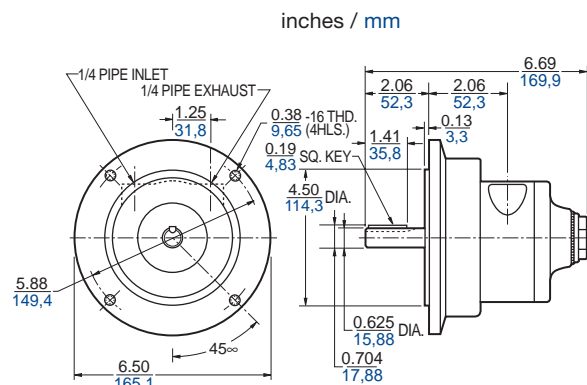



MODEL

4AM-ARV-119

(4 Vanes, Reversible)

4AM-ARV-120

(8 Vanes, Reversible)

FEATURES

- IEC #72 mounting frame size D71
- Any plane operation
- Metal muffler AC980 adds 2" height when installed. (Includes 3/8 BSP adaptor with air motor).

- II 2 GD c T4

RECOMMENDED

- Repair kit K206C (4AM-ARV-119)
- Repair kit K208B (4AM-ARV-120)

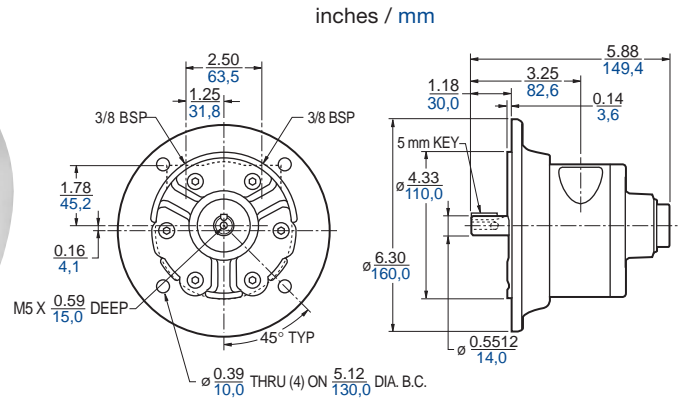

Delivers up to 1,5 kW (2 hp). Speeds may be varied from 300 to 3,000 rpm. Max. recommended operating pressure 7 bar (100 psi).

Note: Performance data represents a 4-vane model with no exhaust restriction.

Output Power vs. Speed

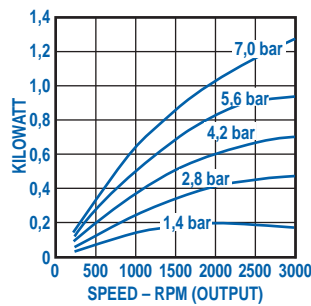
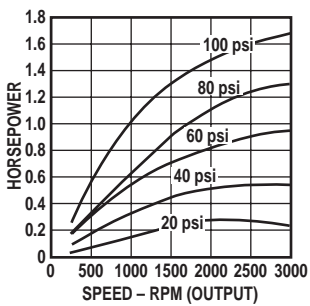

Torque vs. Speed

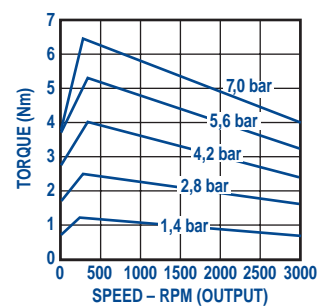
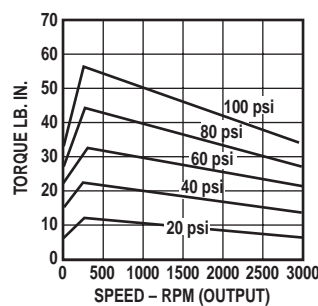

Air Consumption vs. Speed

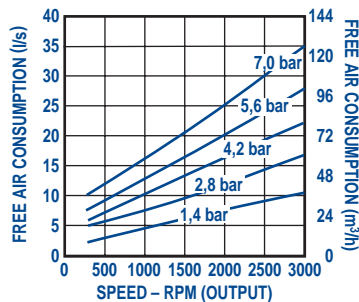
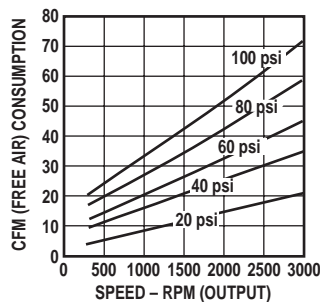



MODEL

6AM-FRV-5A (4 Vanes, Reversible)

6AM-FRV-23A (8 Vanes, Reversible)

Net wt. 21 lbs. (9,5 kg)

FEATURES

- Foot mounting
- Any plane operation
- Metal muffler AC990 adds 2" height when installed
- II 2 GD c T4

RECOMMENDED

- Filter AH106F
- Regulator AH107R
- Gauge AA806
- Lubricator AH108L
- Oil AD220 – 1 quart (.94 litres)
- Repair kit K208 (4 Vane)
- Repair kit K281 (8 Vane)



inches / mm

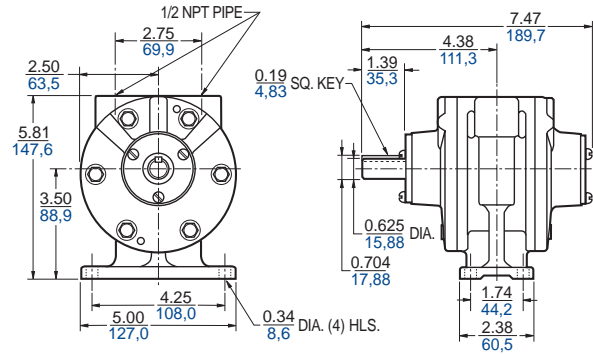

6AM-NRV-7A (4 Vanes, Reversible)

Net wt. 18 lbs. (8,1 kg)

FEATURES

- Face mounting
- Any plane operation
- Muffler AC990 adds 2" height when installed
- II 2 GD c T4

RECOMMENDED

- Filter AH106F
- Regulator AH107R
- Gauge AA806
- Lubricator AH108L
- Oil AD220 – 1 quart (.94 litres)
- Repair kit K208



inches / mm

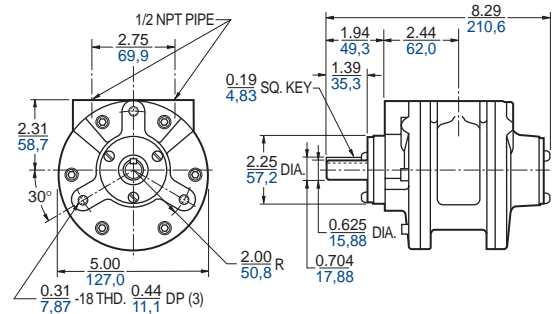

6AM-NRV-11A (4 Vanes, Reversible)

6AM-NRV-22A (8 Vanes, Reversible)

Net wt. 24 lbs. (10,8 kg)

FEATURES

- NEMA 56C mounting
- Any plane operation
- Muffler AC990 adds 2" height when installed
- II 2 GD c T4

RECOMMENDED

- Filter AH106F
- Regulator AH107R
- Gauge AA806
- Lubricator AH108L
- Oil AD220 – 1 quart (.94 litres)
- Repair kit K208 (4 Vane)
- Repair kit K281 (8 Vane)



inches / mm

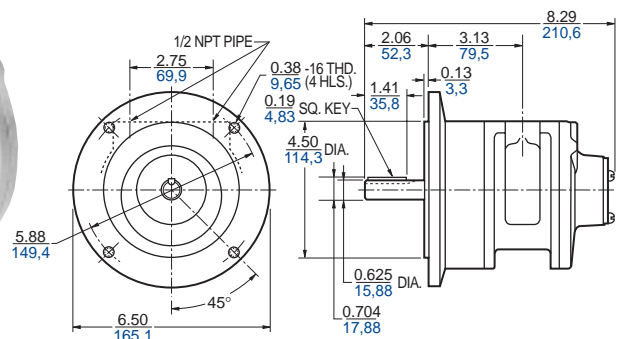



MODEL

6AM-ARV-54

(4 Vanes, Reversible)
Repair kit K281A

6AM-ARV-55

(8 Vanes, Reversible)
Repair kit K281B

FEATURES

- IEC #72 mounting frame size D80
- Any plane operation
- Metal muffler AC990 adds 2" height when installed

- II 2 GD c T4

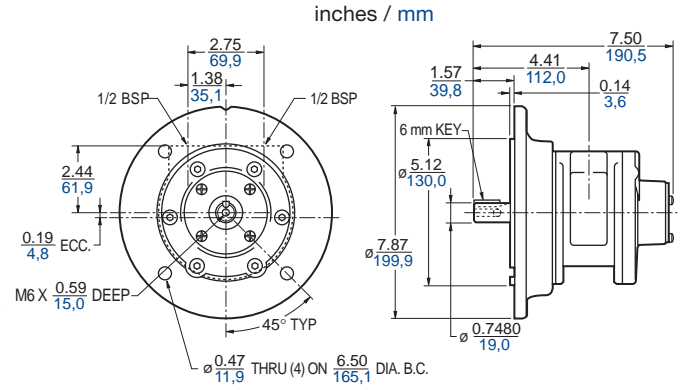

Delivers up to 3 kW (4 hp). Speeds may be varied from 300 to 3,000 rpm. Max. recommended operating pressure 7 bar (100 psi).

Note: Performance data represents a 4-vane model with no exhaust restriction.

Output Power vs. Speed

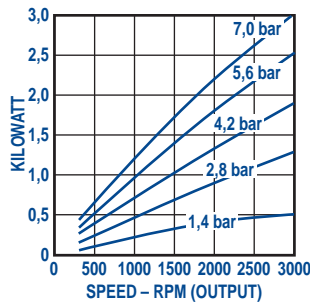
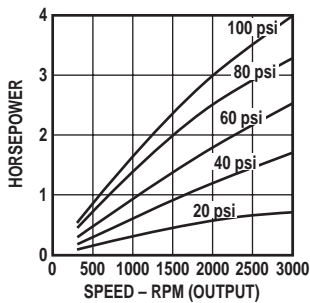

Torque vs. Speed

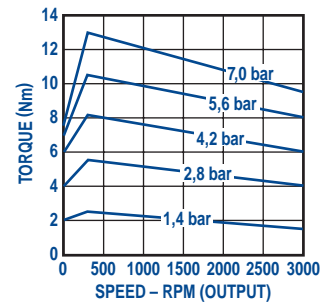
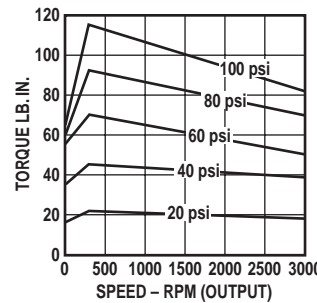

Air Consumption vs. Speed

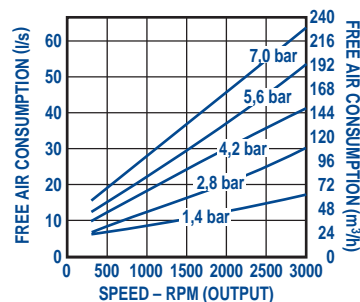
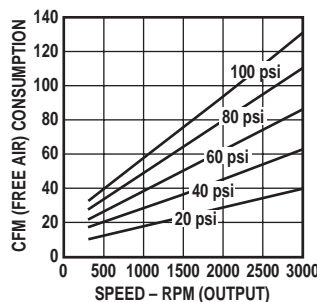



MODEL

8AM-FRV-2B (4 Vanes, Reversible)

8AM-FRV-30A (8 Vanes, Reversible)

Net wt. 27 lbs. (12,2 kg)

FEATURES

- Foot mounting
- Any plane operation
- Metal muffler AC990 adds 2" height when installed

• II 2 GD c T4

RECOMMENDED

- Filter AH106F
- Regulator AH107R
- Gauge AA806
- Lubricator AH108L
- Muffler AG600 – above 1,000 rpm
- Oil AD220 – 1 quart (.94 litres)
- Repair kit K210 (4 Vane)
- Repair kit K283 (8 Vane)

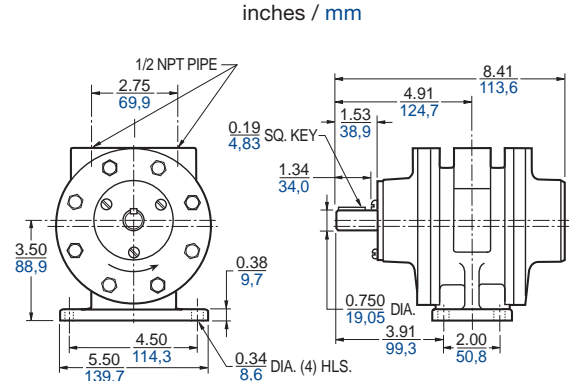

8AM-NRV-5B (4 Vanes, Reversible)

8AM-NRV-42A (8 Vanes, Reversible)

Net wt. 28 lbs. (12,6 kg)

FEATURES

- Face mounting
- Any plane operation
- Metal muffler AC990 adds 2" height when installed

• II 2 GD c T4

RECOMMENDED

- Filter AH106F
- Regulator AH107R
- Gauge AA806
- Lubricator AH108L
- Muffler AG600 – above 1,000 rpm
- Oil AD220 – 1 quart (.94 litres)
- Repair kit K210 (4 Vane)
- Repair kit K283 (8 Vane)

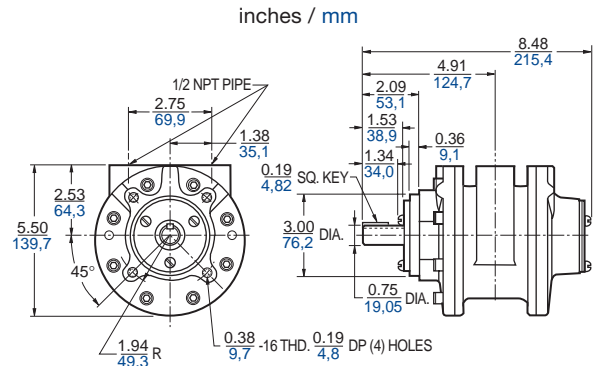

8AM-NRV-28A (4 Vanes, Reversible)

8AM-NRV-32A (8 Vanes, Reversible)

Net wt. 28 lbs. (12,6 kg)

FEATURES

- NEMA 145TC mounting
- Any plane operation
- Metal muffler AC990 adds 2" height when installed

• II 2 GD c T4

RECOMMENDED

- Filter AH106F
- Regulator AH107R
- Gauge AA806
- Lubricator AH108L
- Muffler AG600 – above 1,000 rpm
- Oil AD220 – 1 quart (.94 litres)
- Repair kit K211 (4 Vane)
- Repair kit K282 (8 Vane)

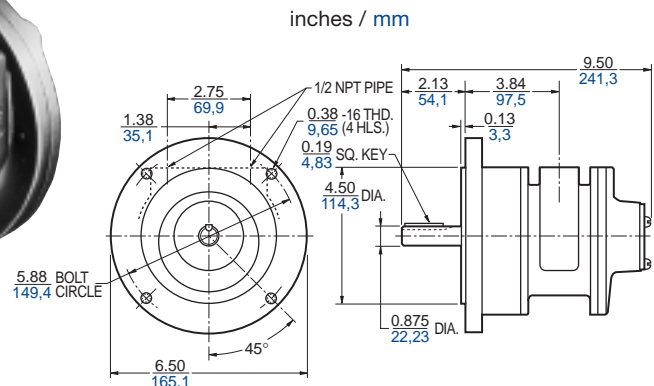



MODEL

8AM-ARV-70

(4 Vanes, Reversible)
Repair kit K282A

8AM-ARV-71

(8 Vanes, Reversible)
Repair kit K282B

FEATURES

- IEC #72 mounting frame size D90
- Any plane operation
- Metal muffler AC990 adds 2" height when installed

- II 2 GD c T4

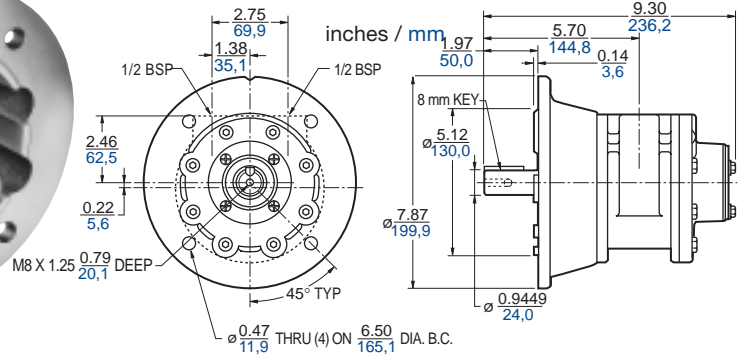

Delivers up to 3,7 kW (5 hp). Speeds may be varied from 300 to 2,500 rpm. Max. recommended operating pressure 7 bar (100 psi).

Note: Performance data represents a 4-vane model with no exhaust restriction.

Output Power vs. Speed

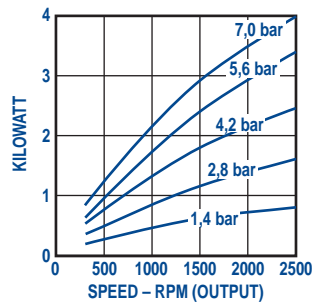
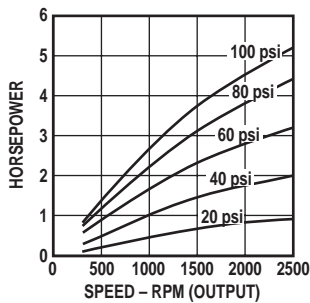

Torque vs. Speed

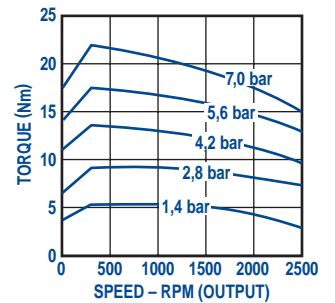
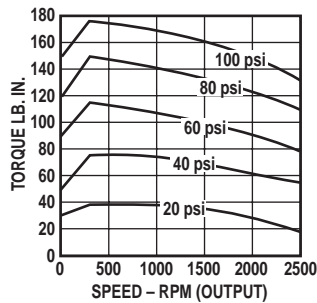

Air Consumption vs. Speed

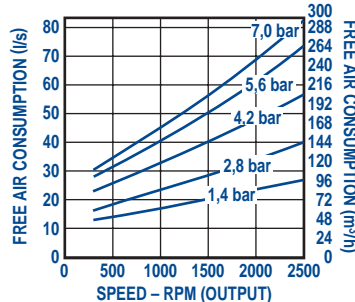
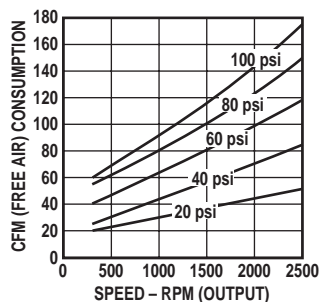



MODEL

16AM-FCC-1

(6 Vanes, CCW Rotation)

16AM-FRV-2

(6 Vanes, Reversible)

16AM-FCW-28

(6 Vanes, CW Rotation)

Net wt. 72 lbs. (32,4 kg) and 73 lbs. (32,9 kg) respectively.

FEATURES

- Foot, face mounting
- Any plane operation
- II 2 GD c T4

RECOMMENDED

- Filter AH109F
- Regulator AH110R
- Gauge AA806
- Lubricator AH111L
- Muffler AG601
- Oil AD220 – 1 quart (.94 litres)
- Repair kit K212 (Single Rotation)
- Repair kit K213 (Reversible)

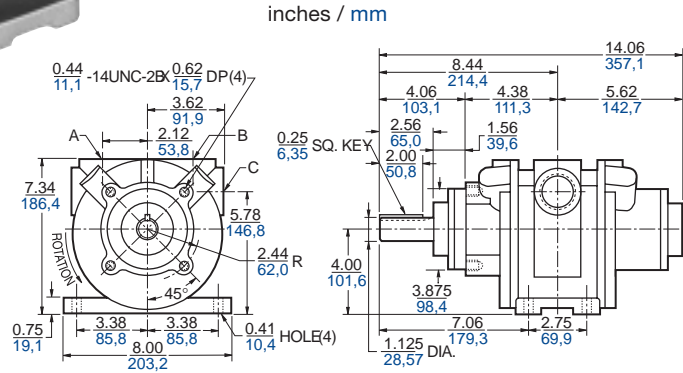
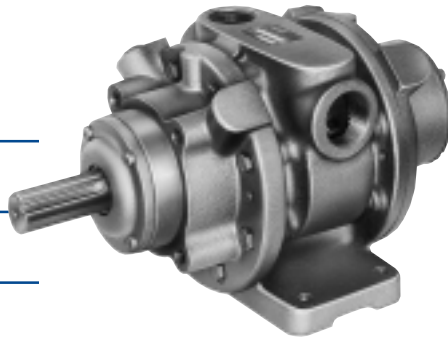

Rotation	A	B	C
Single direction	1 PIPE	NONE	1 1/4 PIPE
Reversible	1 1/4 PIPE	1 1/4 PIPE	NONE

16AM-FRV-13

(6 Vanes, Reversible)

Net wt. 80 lbs. (36,0 kg)

FEATURES

- NEMA 143 & 145TC mounting
- Any plane operation
- II 2 GD c T4

RECOMMENDED

- Filter AH109F
- Regulator AH110R
- Gauge AA806
- Lubricator AH111L
- Muffler AG601
- Oil AD220 – 1 quart (.94 litres)
- Repair kit K213

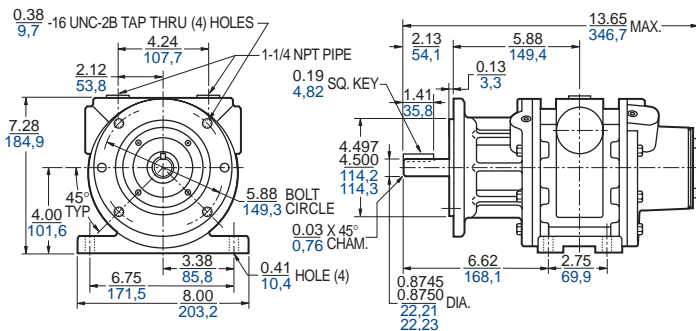
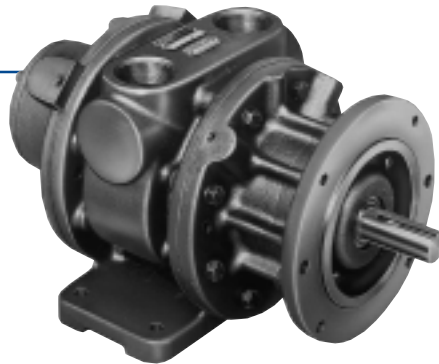

Output Power vs. Speed

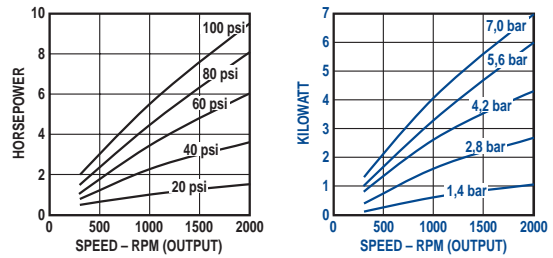

Torque vs. Speed

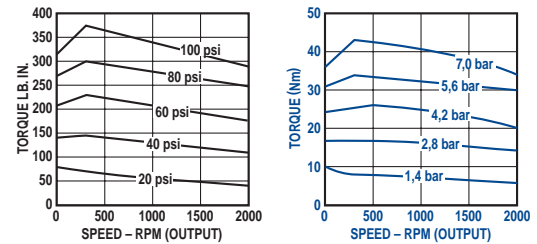

Air Consumption vs. Speed

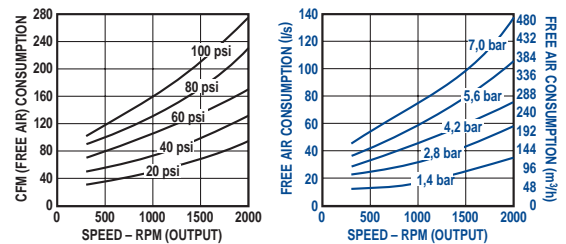



The NL Series - an alternative to our traditional lubricated styles because no lubricator is necessary



For those air motor applications where contaminated exhaust cannot be tolerated in the workplace, Gast's non-lubricated air motors, the NL series, provide the solution.

- **Rugged and reliable**

Like our traditional lubricated air motors, the NL series will provide thousands of hours of service-free life. Vanes are just as easy and inexpensive to replace.

- **Performance flexibility**

Gast's non-lubricated air motors are designed so that compressor carry-over will not gum up the vanes. In fact, while no lubrication whatsoever is required to operate the motors, small amounts of oil and water will actually improve the performance.

- **Corrosion resistant**

Because the body, rotor and end plates are specially treated, these air motors can tolerate unfavorable moisture-laden conditions.

- **No oil expenses**

If you are using several quarts of oil throughout the year, you'll eliminate that expense with non-lubricated air motors.

- **No periodic inspection**

With no in-line lubrication system to replenish, the need for time consuming maintenance checks is eliminated.

Gast's non-lubricated Air Motors provide the advantages and benefits of traditional lubricated Air Motors which include:

- **Variable speed**
- **Nonelectrical sparking**
- **Cool running**
- **Minimal maintenance**
- **No-shock starts**
- **Any plane operation**



MODEL

NL22-NCC-1

(4 Vanes, CCW Rotation)

NL22-NCW-2

(4 Vanes, CW Rotation)

NL22-FCC-3

(4 Vanes, CCW Rotation)

NL22-FCW-4

(4 Vanes, CW Rotation)

Net wt. 3 lbs. (1,4 kg)

FEATURES

- Hub or foot mounting
- Treated body, rotor, and end plates for corrosion resistance
- No lubrication necessary - no contaminated air in the work area
- Any plane operation
- Muffler AF350

• II 2 GD c T4

RECOMMENDED

- Filter AH100F
- Regulator AH101R
- Gauge AA807
- Repair kit K285A

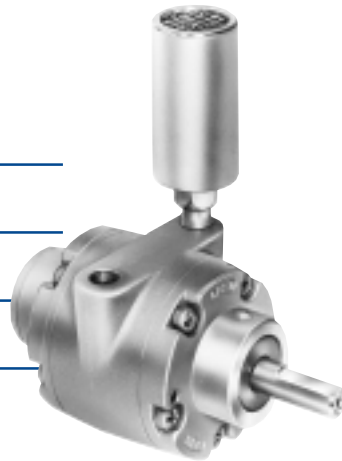

Hub mounting model shown with muffler attached

Hub mounting (NL22-NCC-1, NL22-NCW-2)

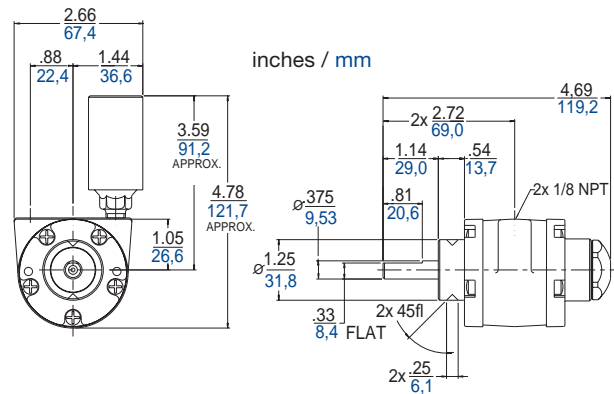

Foot mounting (NL22-FCC-3, NL22-FCW-4)

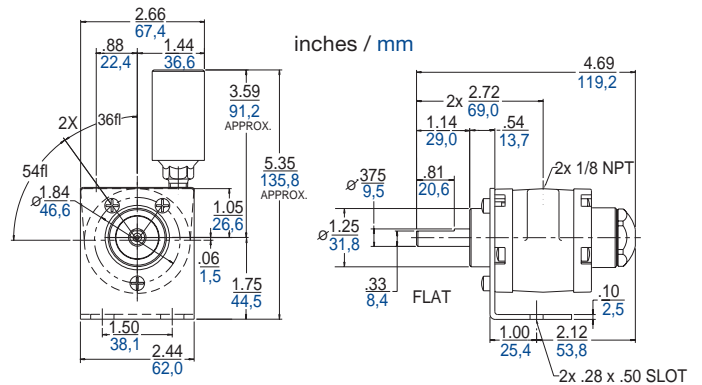

Output Power vs. Speed

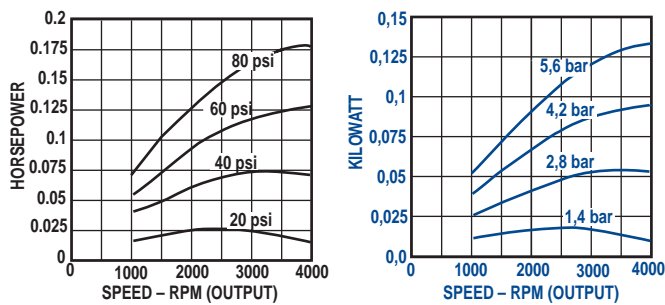

Torque vs. Speed

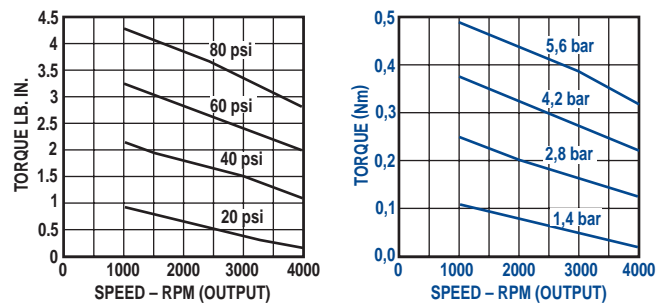

Air Consumption vs. Speed

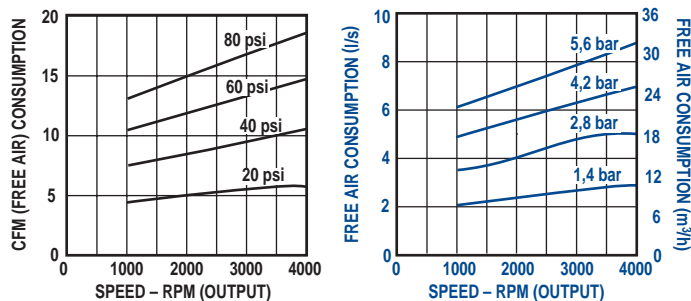



Non-lubricated Air Motors

up to .42 hp, speeds from 300 to 2,000 rpm, maximum pressure 80 psi (5,6 bar)



MODEL

NL32-NCC-1

(4 Vanes, CCW Rotation)

NL32-NCW-2

(4 Vanes, CW Rotation)

Net wt. 9 lbs. (4,1 kg)

NL32-NCC-5

(4 Vanes, CCW Rotation)

NL32-NCW-6

(4 Vanes, CW Rotation)

NL32-NCC-7

(4 Vanes, CCW Rotation)

NL32-NCW-8

(4 Vanes, CW Rotation)

Net wt. 12 lbs. (5,4 kg)

FEATURES

- Hub or foot mounting
- Treated body, rotor, and end plates for corrosion resistance
- No lubrication necessary - no contaminated air in the work area
- Any plane operation
- Metal muffler AC980 adds 2" height when installed

- II 2 GD c T4

RECOMMENDED

- Filter AH103F
- Regulator AH104R
- Gauge AA806
- Repair kit K521

OPTIONAL

- Foot kit AL220 - each of these models can be turned into foot mounted styles with the installation of optional foot kit AL220, which will add approx. 2" height to the air motor

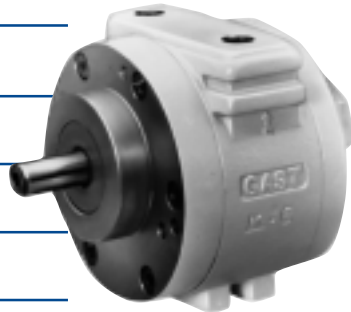

- Hub mounting model shown with optional foot assembly kit which can be purchased separately.
- Flange style is shown in schematic

Hub mounting (NL32-NCC-1, NL32-NCW-2)

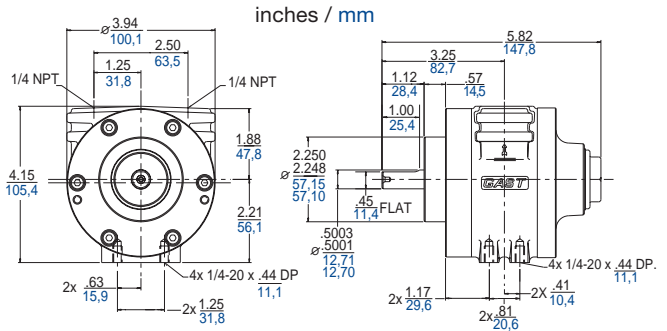

NEMA 56C, U.S. - (NL32-NCC-5, NL32-NCW-6) D71 Flange, Metric - (NL32-NCC-7, NL32-NCW-8)

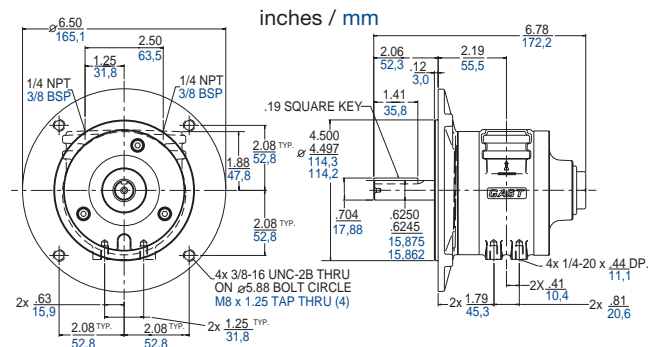

Output Power vs. Speed

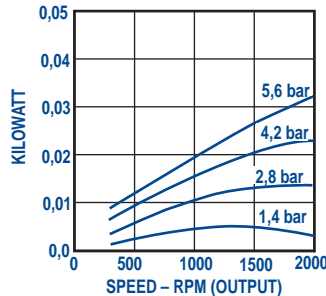
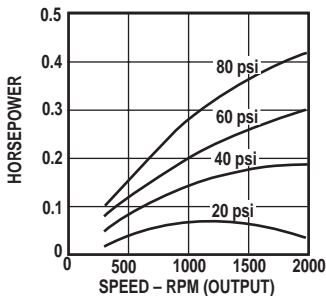

Torque vs. Speed

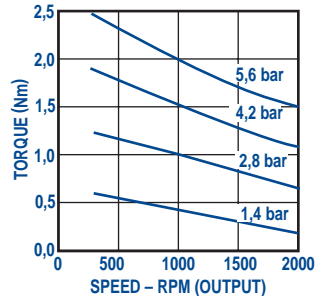
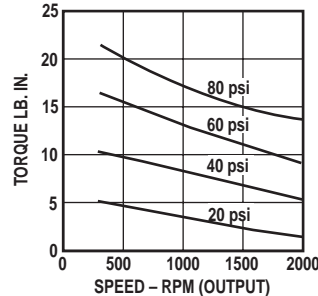

Air Consumption vs. Speed

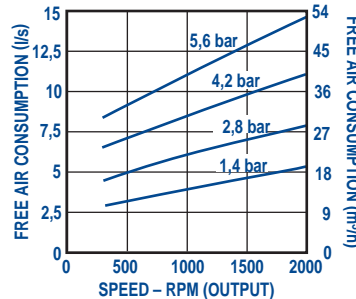
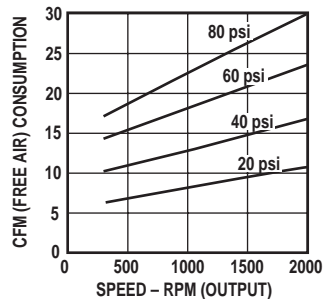



MODEL

NL42-NCC-1

(4 Vanes, CCW Rotation)

NL42-NCW-2

(4 Vanes, CW Rotation)

Net wt. 18 lbs. (8,2 kg)

NL42-NCC-5

Vanes, CCW Rotation)

NL42-NCW-6

(4 Vanes, CW Rotation)

NL42-NCC-7

(4 Vanes, CCW Rotation)

Net wt. 21 lbs. (9,5 kg)



FEATURES

- Hub or foot mounting
- Treated body, rotor, and end plates for corrosion resistance
- No lubrication necessary - no contaminated air in the work area
- Any plane operation
- Metal muffler AC980 adds 2" height when installed

- II 2 GD c T4

RECOMMENDED

- Filter AH103F
- Regulator AH104R
- Gauge AA806
- Repair kit K580

- Hub mounting model shown with optional foot assembly kit which can be purchased separately.

OPTIONAL

- Foot kit AL414 - each of these models can be turned into foot mounted styles with the installation of optional foot kit AL414, which will add approx. 2" height to the air motor

Hub mounting (NL42-NCC-1, NL42-NCW-2)

inches / mm

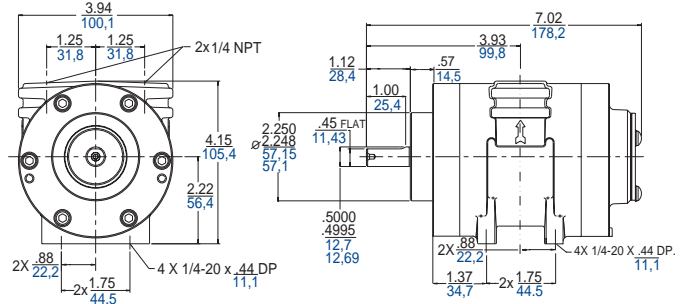

NEMA 56C, U.S. - (NL42-NCC-5, NL42-NCW-6)

D71 Flange, Metric - (NL42-NCC-7)

inches / mm

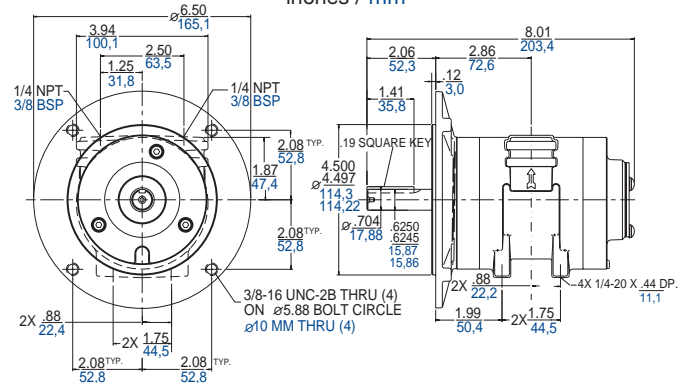

Output Power vs. Speed

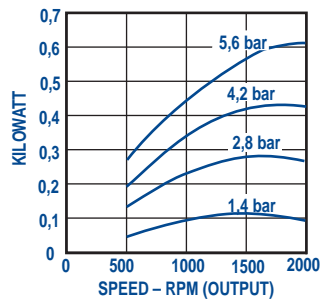
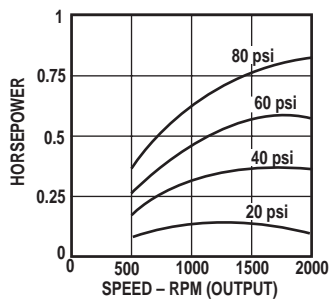

Torque vs. Speed

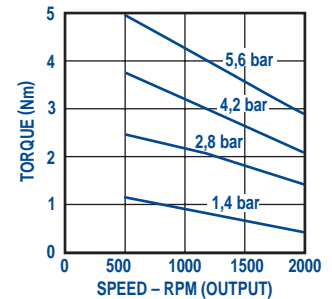
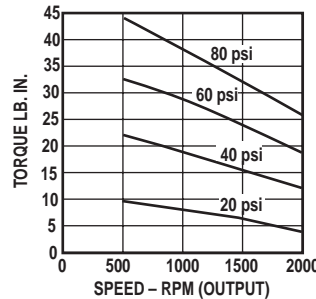

Air Consumption vs. Speed

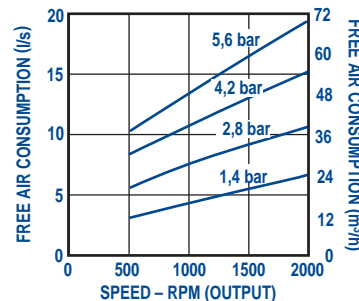
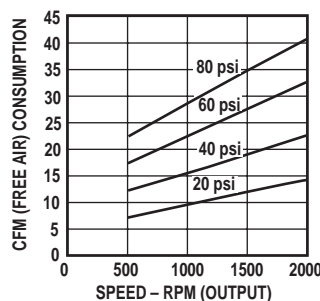



Non-lubricated Air Motors

up to 2.5 hp, speeds from 500 to 2,000 rpm, maximum pressure 80 psi (5,6 bar)



MODEL

NL52-NCC-1

(4 Vanes, CCW Rotation)

NL52-NCW-2

(4 Vanes, CW Rotation)

Net wt. 13 lbs. (6 kg)

NL52-NCC-3

(4 Vanes, CCW Rotation)

NL52-NCW-4

(4 Vanes, CW Rotation)

Net wt. 14.5 lbs. (6,6 kg)



FEATURES

- Hub, NEMA 56C, 6AM, or foot mounting
- Treated body, rotor, and end plates for corrosion resistance
- No lubrication necessary - no contaminated air in the work area
- Any plane operation
- Metal muffler AC990 adds 2" height when installed

- II 2 GD c T4

RECOMMENDED

- Filter AH106F
- Regulator AH107R
- Gauge AA806
- Repair kit K833

OPTIONAL

- Foot kit AL414 - each of these models can be turned into foot mounted styles with the installation of optional foot kit AL414, which will add approx. 2" height to the air motor

- Hub mounting model shown with optional foot assembly kit which can be purchased separately.

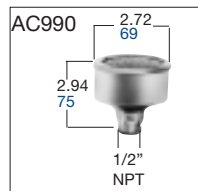

Hub mounting (NL52-NCC-1, NL52-NCW-2)

inches / mm

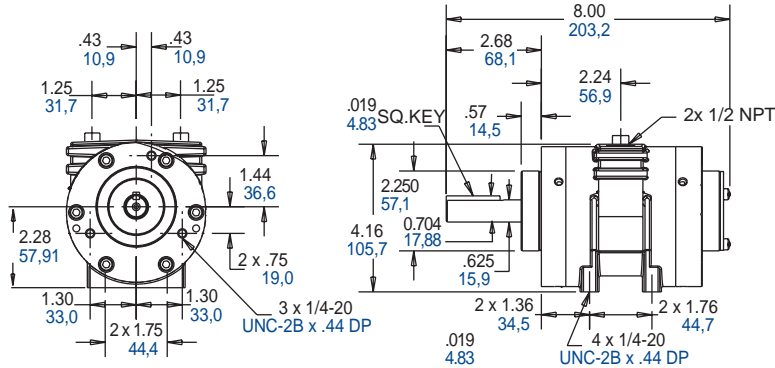

NEMA 56C, U.S. - (NL52-NCC-3, NL52-NCW-4)

inches / mm

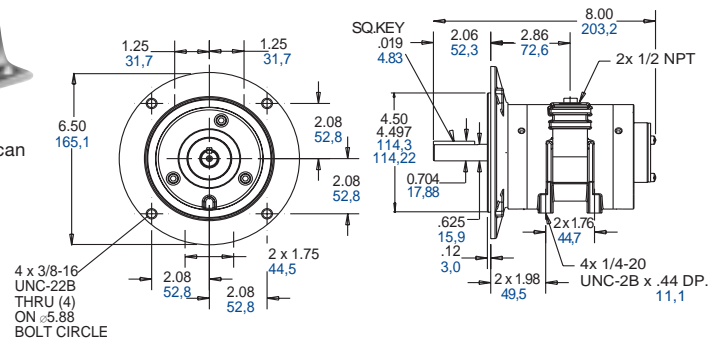

6AM Hub Mounting (NL52-NCC-5, NL52-NCW-6)

Mounting identical to 6AM-NRV-7A for field replacement

inches / mm

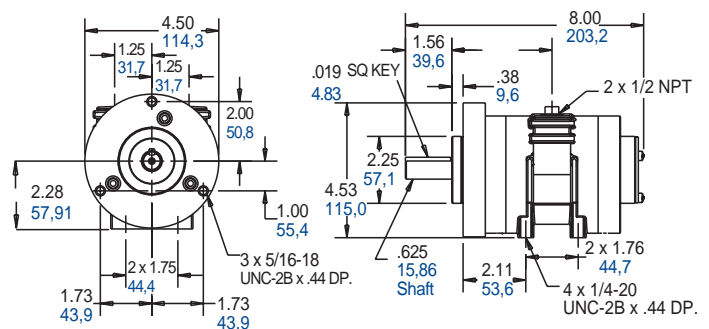

Air Consumption vs. Speed

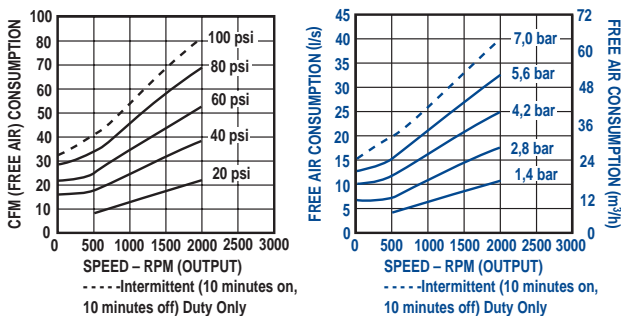

Torque vs. Speed

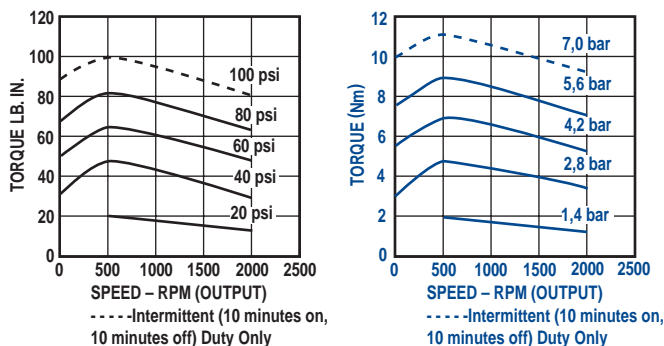

Output Power vs. Speed

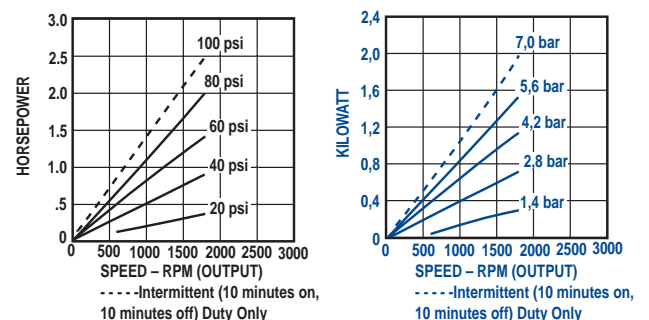



Get the right gearmotor with all the right options.

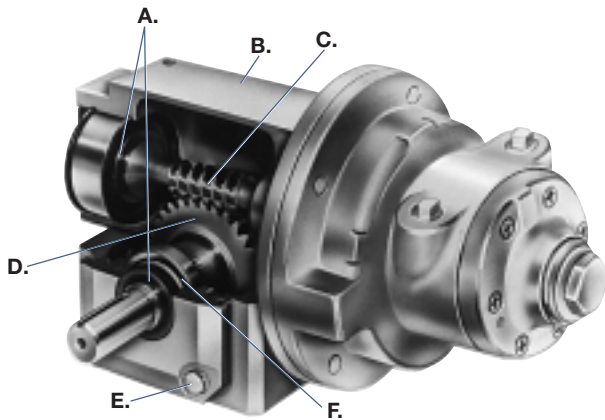

Pictured: typical rightangle, worm gear reducer.

A. Bearings

Ball bearings used on input shaft; tapered roller bearings used on output shaft.

B. Case

Fine close-grain cast iron; crankcase sealed; duplex-milled for parallelism of mounting surfaces.

C. Worm

8620 alloy steel thread rolled to give uninterrupted grain pattern; carburized and hardened after rolling; high-burnish contact surface from rolling reduces friction coefficient for less heat generation, lower power losses. In large sizes, worms are cut, hardened, and ground to a good micro-finish, providing the ultimate in efficiency and torque capacity.

D. Worm Gear

Forged bronze; geometry and high helix angle give maximum beam strength, high efficiency.

E. Cap Screw

High-strength fasteners with corresponding torque specifications prevent loosening or breaking.

F. Seals

Double-dipped and spring-loaded for leak proofing; tested to ensure compatibility with lubricant.

More reasons why you should switch from electricity to air.

If you compare Gast Air-Powered Gearmotors with any electric-powered gearmotor, there's really no comparison. Here's why:

- **More horsepower.**

Size for size, weight for weight, you can't beat a Gast Gearmotor. A typical rotary vane air motor – the type used in gearmotors – developing 2½ hp (1,9 kW) at 1800 rpm and 90 psi (6,2 bar), weighs just 17 pounds (7,7 kg). A comparable electric motor may be two or three times heavier.

- **More speed control.**

You can't get more precise turning power than with a Gast Gearmotor. In applications where you need variable speed – like bolt tensioning equipment or rock drilling rigs – one-speed electric motors just won't fit the bill. Precise lifting, lowering, or turning is simple with Gast Gearmotors.

- **More flexibility.**

More than most standard electric-powered gear reducers can provide. Gast Gearmotors give you infinitely variable turning power from 73 to 5200 lb. in. (8 to 587 Nm) of torque. And Gast Gearmotors are instantly reversible through easy valving in the air line.

- **More configurations.**

That makes it easier for our product to work in your product. Our gearmotors are available in four mounting configurations.

- **More life.**

Unlike electric-powered gearmotors, there's no chance of burnout with a Gast Gearmotor. They can be stalled indefinitely with no heat buildup. They're nonelectrical sparking, too, which makes them ideal for use in potentially explosive environments – places where you couldn't even consider electricity.

⚠WARNING: Gast Air Powered Gearmotors are not self-locking. In applications where a break is required for safety in case of air pressure failure, call 800/952-4278 for your nearest distributor.

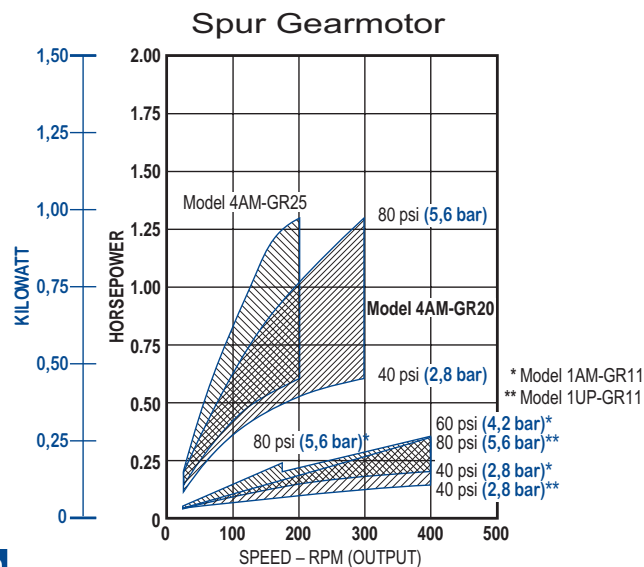



Air-Powered Gearmotors

2AM Series, 20:1 reduction



MODEL

2AM-43A-AF20

(4 Vanes, Reversible)

Net wt. 24 lbs. (10,9 kg)

FEATURES

- 20:1 gear reducer
- Flange mounting
- Base-mounted
- Metal muffler AC980 provided not shown. AC980 adds 2" height when installed.

RECOMMENDED

- Filter AH103F
- Regulator AH104R
- Gauge AA806
- Lubricator AH105L
- Oil AD220 – 1 quart (.94 litres)
- Repair kit K509

Max allowable overhung load on the output shaft is 240 lbs. Max allowable thrust load on the output shaft is 300 lbs.

Counter-clockwise output shaft rotation

inches / mm

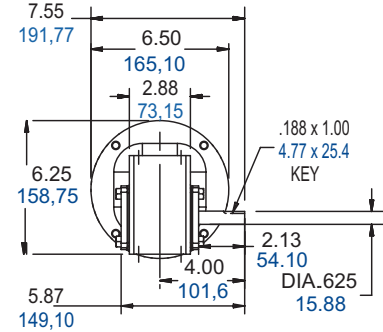
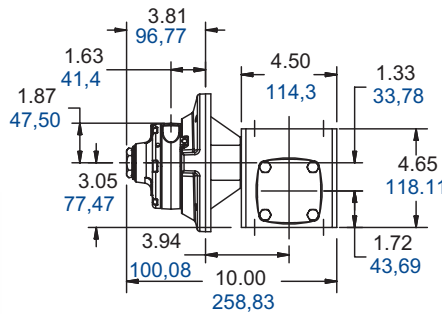
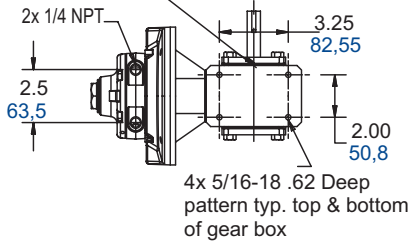

Air Consumption vs. Speed

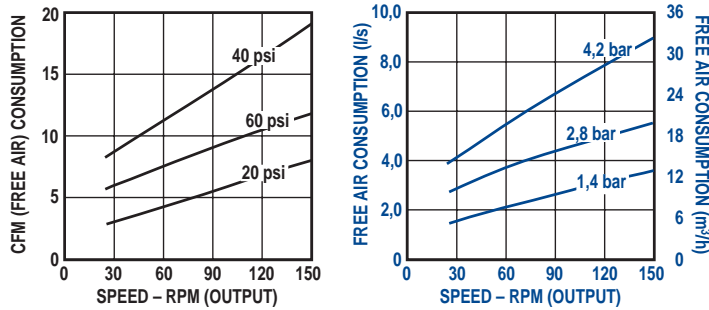

Output Power vs. Speed

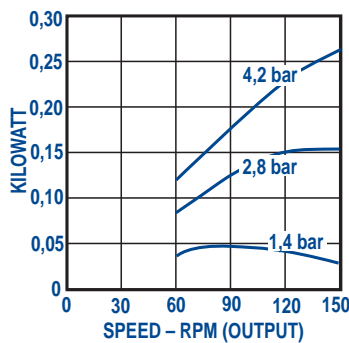
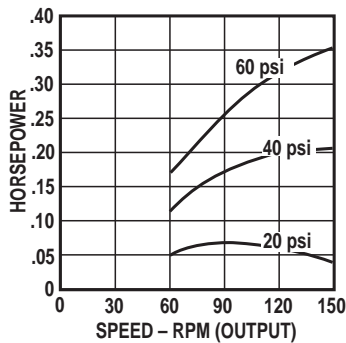

Torque vs. Speed

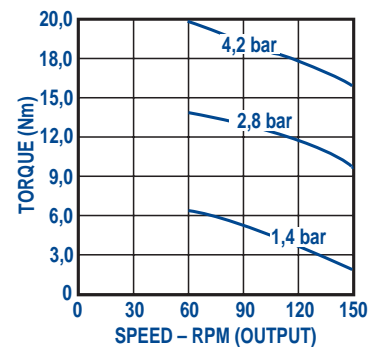
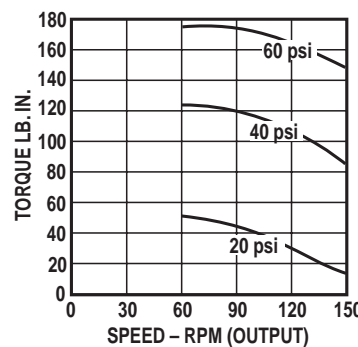



Max allowable overhung load on the output shaft is 600 lbs. Max allowable thrust load on the output shaft is of 500 lbs.

MODEL

2AM-43A-BF20

(4 Vanes, Reversible)

Net wt. 33.55 lbs. (15,2 kg)

FEATURES

- 20:1 gear reducer
- FLANK mounting
- Mount on any plane operation
- Metal muffler AC980 provided not shown. AC980 adds 2" height when installed.

RECOMMENDED

- Filter AH103F
- Regulator AH104R
- Gauge AA806
- Lubricator AH105L
- Oil AD220 – 1 quart (.94 litres)
- Repair kit K509

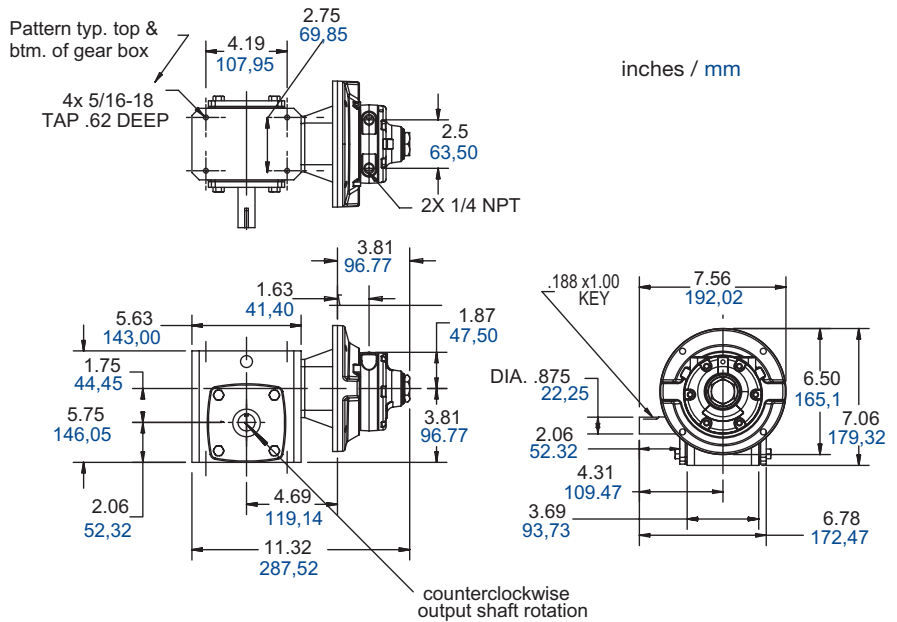

Air Consumption vs. Speed

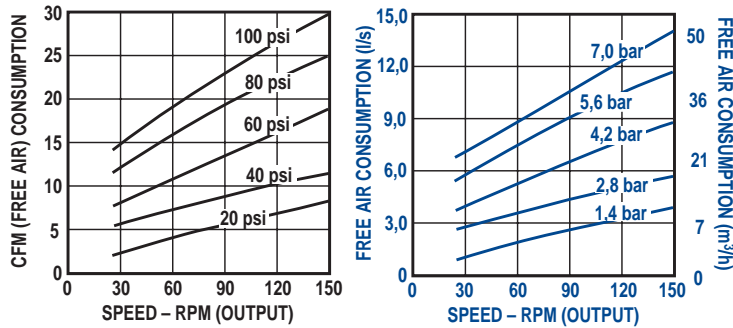

Output Power vs. Speed

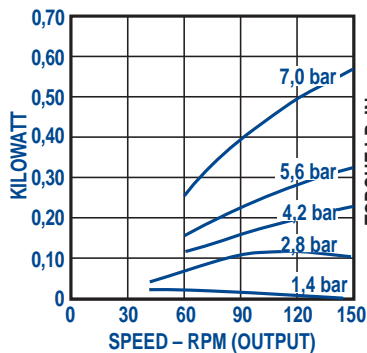
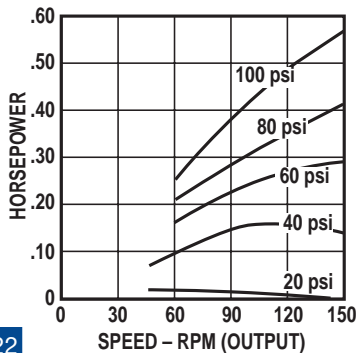

Torque vs. Speed

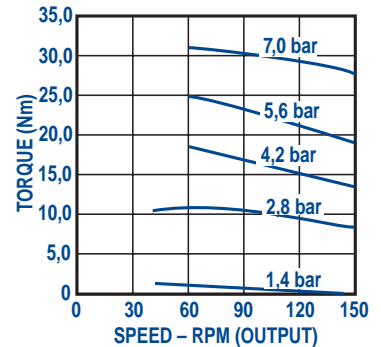
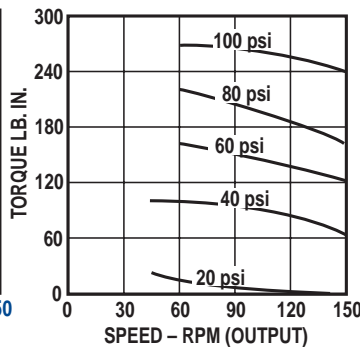



Air-Powered Gearmotors

1AM and 1UP Series, 15:1 reduction, 10 – 95 lbs. in. (1 – 11 Nm) torque at 40 rpm (minimum speed)



MODEL

1AM-NRV-56-GR11

(4 Vanes, Reversible)

1AM-NRV-60-GR11

(8 Vanes, Reversible)

Net wt. 5 lbs. (2,3 kg)

FEATURES

- 15:1 gear reducer
- Face mounting
- Horizontal or shaft down operation
- Muffler AF350 (shown in photo)

• II 2 GD c T4

RECOMMENDED

- Filter AH100F
- Regulator AH101R
- Gauge AA806
- Lubricator AH102L
- Oil AD220 – 1 quart (.94 litres)
- Repair kit K278 (Air motor only, 8 Vane)
- Repair kit K201 (Air motor only, 4 Vane)

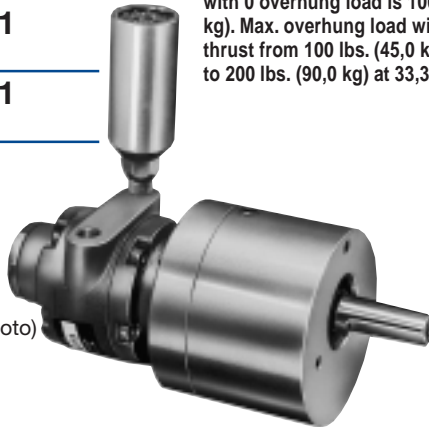

Max. allowable end thrust with 0 overhung load is 100 lbs. (45,0 kg). Max. overhung load with 0 end thrust from 100 lbs. (45,0 kg) at 333 rpm to 200 lbs. (90,0 kg) at 33,3 rpm.

Output Power vs. Speed

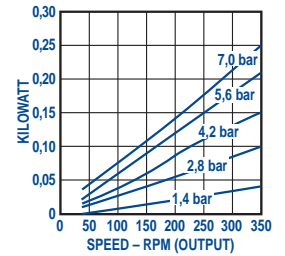
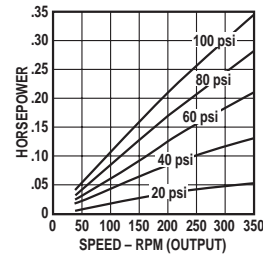

Torque vs. Speed

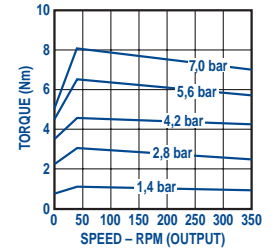
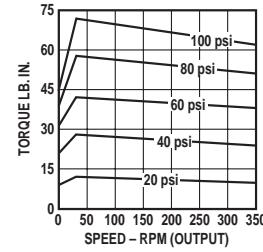

Air Consumption vs. Speed

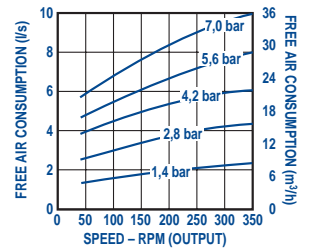
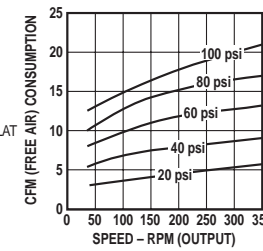

inches / mm

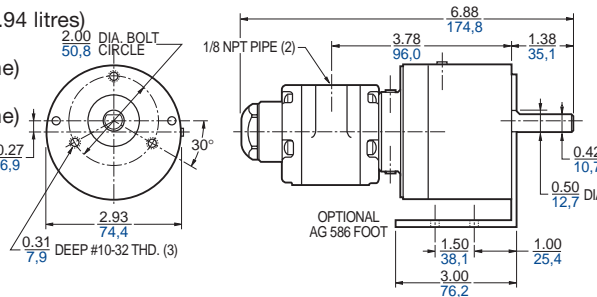

MODEL

1UP-NRV-4-GR11

(4 Vanes, Reversible)

1UP-NRV-11-GR11

(8 Vanes, Reversible)

Net wt. 5 lbs. (2,3 kg)

FEATURES

- 15:1 gear reducer
- Face mounting
- Horizontal or shaft down operation
- Muffler AF350 (shown in photo)

• II 2 GD c T4

RECOMMENDED

- Filter AH100F
- Regulator AH101R
- Gauge AA806
- Lubricator AH102L
- Oil AD220 – 1 quart (.94 litres)
- Repair kit K298 (Air motor only, 8 Vane)
- Repair kit K286 (Air motor only, 4 Vane)

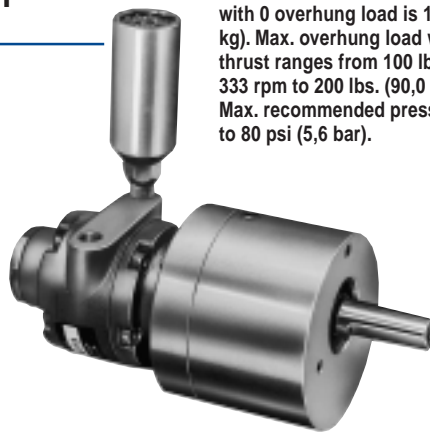

Max. allowable end thrust with 0 overhung load is 100 lbs. (45,0 kg). Max. overhung load with 0 end thrust ranges from 100 lbs. (45,0 kg) at 333 rpm to 200 lbs. (90,0 kg) at 33,3 rpm. Max. recommended pressures to 80 psi (5,6 bar).

Output Power vs. Speed

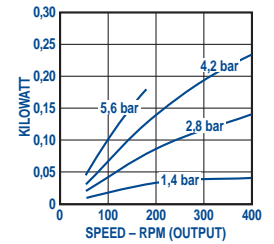
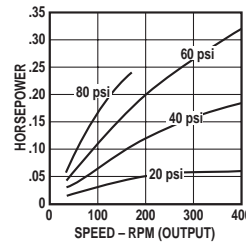

Torque vs. Speed

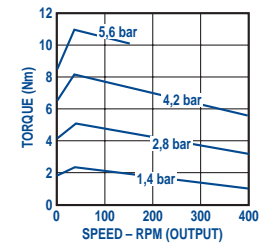
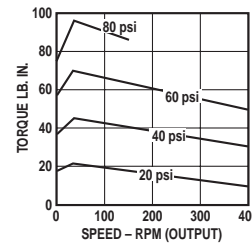

Air Consumption vs. Speed

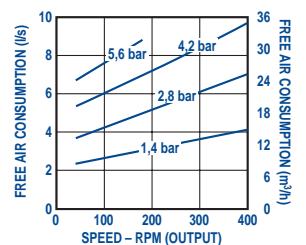
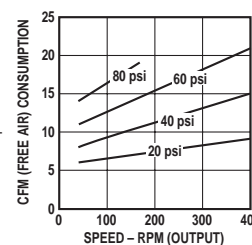

inches / mm

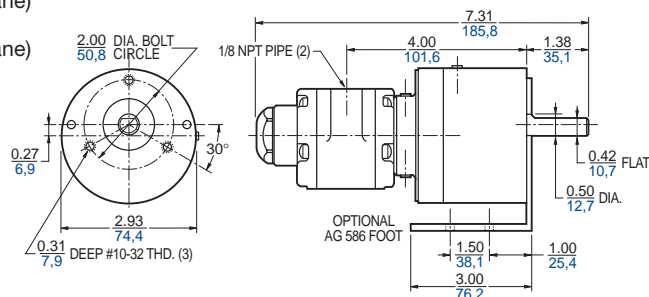

GAST Air-Powered Gearmotors

4AM Series, 10 and 15:1 reduction, 100 – 630 lbs. in. (11 – 72 Nm) torque at 30 rpm (minimum speed reduction)



MODEL

4AM-RV-75-GR20

(4 Vanes, Reversible)

Net wt. 28 lbs. (12,6 kg)

FEATURES

- 10:1 gear reducer
- Face, foot mounting
- Horizontal or shaft down operation
- Metal muffler AC980 adds 2" height when installed

- II 2 GD c T4

RECOMMENDED

- Filter AH103F
- Regulator AH104R
- Gauge AA806
- Lubricator AH105L
- Oil AD220 – 1 quart (.94 litres)
- Repair kit K205 (Air motor only)

Max. allowable end thrust with 0 overhung load ranges from 200 lbs. (90,0 kg) at 300 rpm to 800 lbs. (360,0 kg) at 30 rpm. Max. overhung load with 0 end thrust ranges from 200 lbs. (90,0 kg) at 300 rpm to 600 lbs. (270,0 kg) at 30 rpm. Max. recommended pressures to 80 psi (5,6 bar).



inches / mm

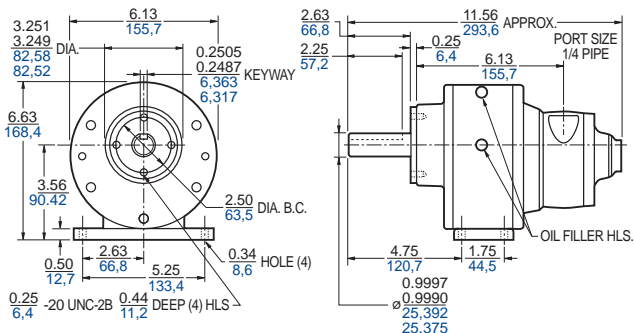

Output Power vs. Speed

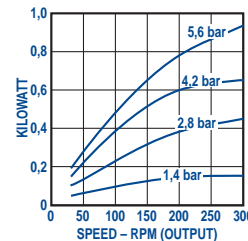
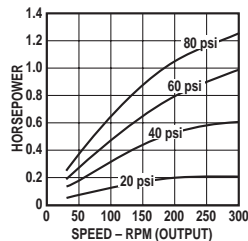

Torque vs. Speed

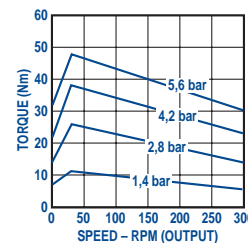
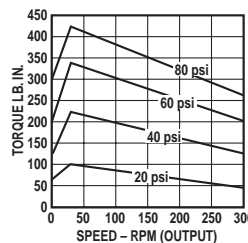

Air Consumption vs. Speed

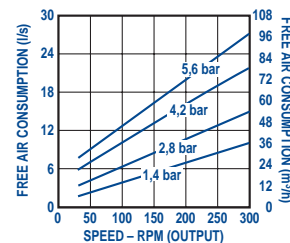
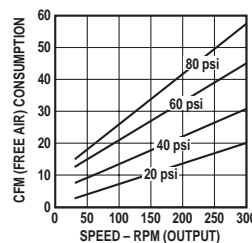

MODEL

4AM-RV-75-GR25

(4 Vanes, Reversible)

Net wt. 28 lbs. (12,6 kg)

FEATURES

- 15:1 gear reducer
- Face, foot mounting
- Horizontal or shaft down operation
- Metal muffler AC980 adds 2" height when installed

- II 2 GD c T4

RECOMMENDED

- Filter AH103F
- Regulator AH104R
- Gauge AA806
- Lubricator AH105L
- Oil AD220 – 1 quart (.94 litres)
- Repair kit K205 (Air motor only)

Max. allowable end thrust with 0 overhung load ranges from 250 lbs. (112,5 kg) at 200 rpm to 800 lbs. (360,0 kg) at 20 rpm. Max. overhung load with 0 end thrust ranges from 200 lbs. (90,0 kg) at 200 rpm to 600 lbs. (270,0 kg) at 20 rpm. Max. recommended pressures to 80 psi (5,6 bar).



inches / mm

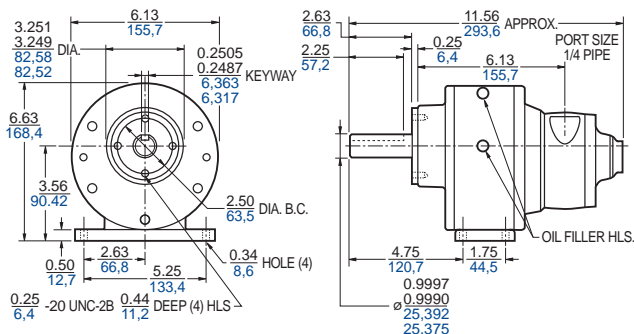

Output Power vs. Speed

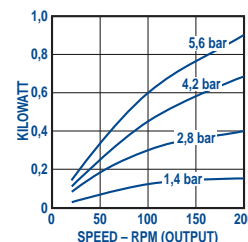
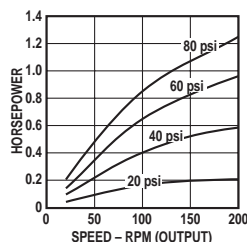

Torque vs. Speed

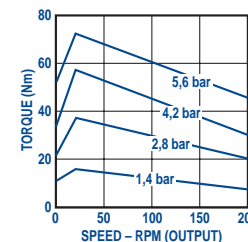
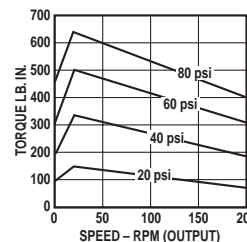

Air Consumption vs. Speed

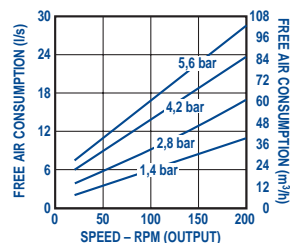
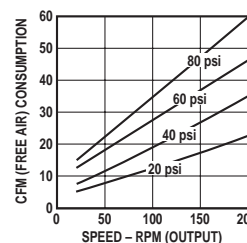



Air-Powered Gearmotors

4AM Series, 20:1 reduction, 100 – 750 lbs. in. (10 – 82 Nm) torque at 15 rpm (minimum speed reduction)



MODEL

4AM-70C-CB20

(8 Vanes, Reversible)

Net wt. for standard configuration
60 lbs. (27,0 kg)

FEATURES

- 20:1 gear reducer
- Base mounting
- Optional mountings and shaft locations available
- Metal muffler AC980 adds 2" height when installed

RECOMMENDED

- Filter AH103F
- Regulator AH104R
- Gauge AA806
- Lubricator AH105L
- Oil AD220 – 1 quart (.94 litres)
- Repair kit K280A (Air motor only)

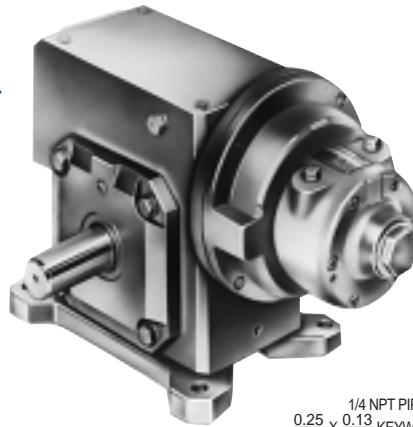

Max. allowable end thrust with 0 overhung load is 2259 lbs. (1016,6 kg) at 30 rpm to 1335 lbs. (600,8 kg) at 150 rpm. Max. overhung load on output shaft with 0 end thrust 1601 lbs. (720,4 kg).

"B" Mounting (photo)

4AM-70C-CB20 / *4AM-70C-CF20
(standard shaft) / (opposite shaft)

inches / mm

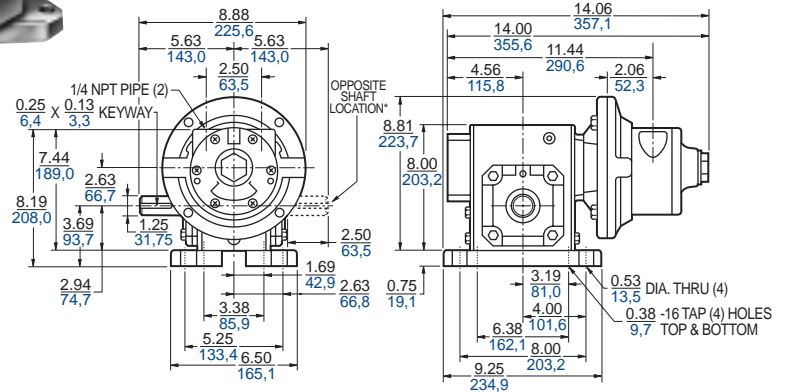

Output Power vs. Speed

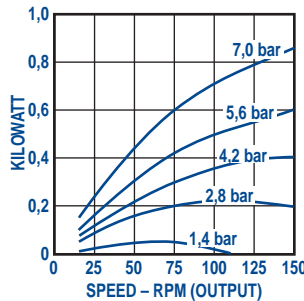
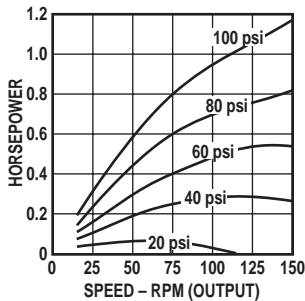

Air Consumption vs. Speed

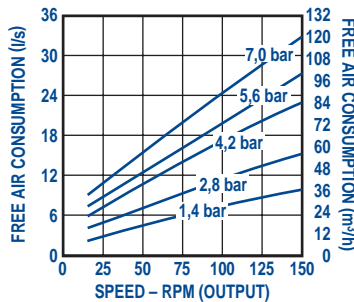
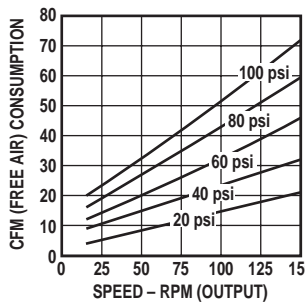

"C" Mounting

4AM-70C-CC20 / *4AM-70C-CG20
(standard shaft) / (opposite shaft)

inches / mm

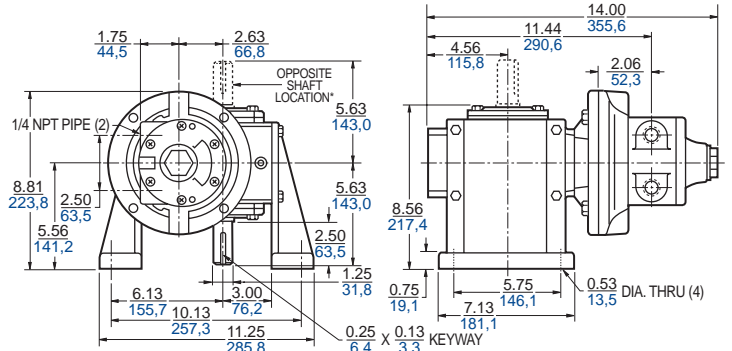

"D" Mounting

4AM-70C-CD20 / *4AM-70C-CH20
(standard shaft) / (opposite shaft)

inches / mm

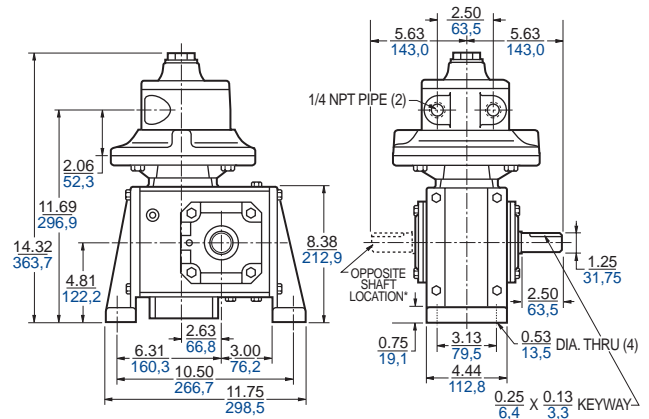

Torque vs. Speed

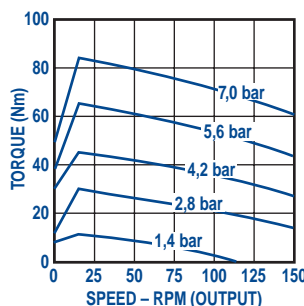
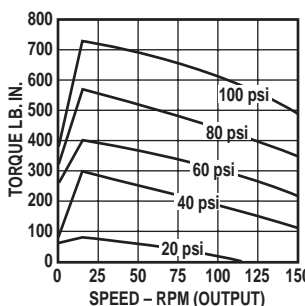



Air-Powered Gearmotors

4AM Series, 40:1 reduction, 100 – 1250 lbs. in. (11 – 140 Nm) torque at 10 rpm (minimum speed reduction)



MODEL

4AM-70C-CB40

(8 Vanes, Reversible)

Net wt. for standard configuration
60 lbs. (27,0 kg)

FEATURES

- 40:1 gear reducer
- Base mounting
- Optional mounting and shaft locations available
- Metal muffler AC980 adds 2" height when installed

RECOMMENDED

- Filter AH103F
- Regulator AH104R
- Gauge AA806
- Lubricator AH105L
- Oil AD220 – 1 quart (.94 litres)
- Repair kit K280A (Air motor only)

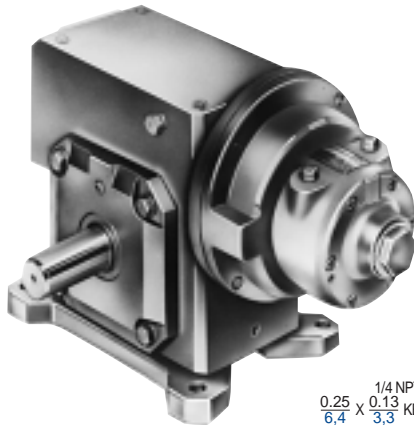

Max. allowable end thrust with 0 overhang load is 3049 lbs. (1372,1 kg) at 15 rpm to 1823 lbs. (820,4 kg) at 75 rpm. Max. overhang load on output shaft with 0 end thrust 1601 lbs. (720,5 kg).

"B" Mounting (photo) 4AM-70C-CB40 / *4AM-70C-CF40 (standard shaft) / (opposite shaft)

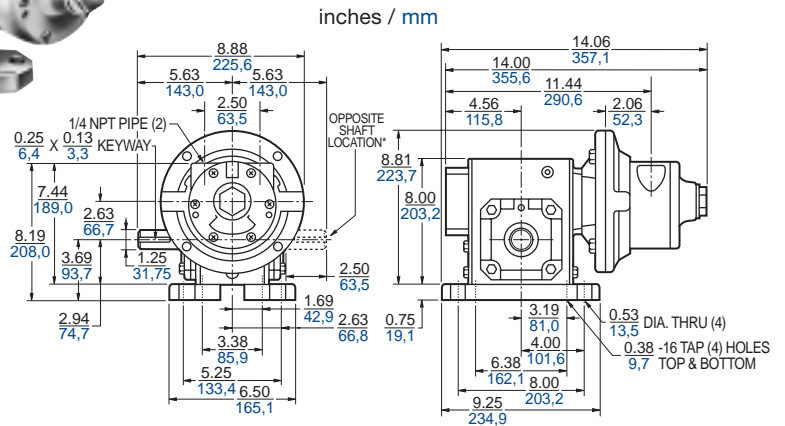

Output Power vs. Speed

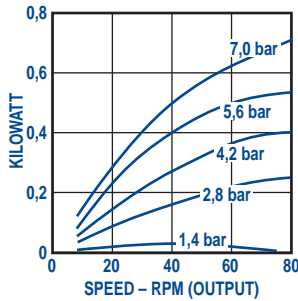
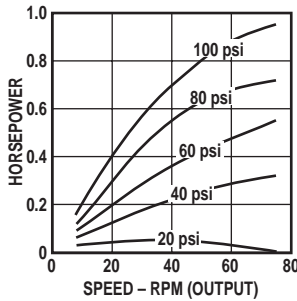

Air Consumption vs. Speed

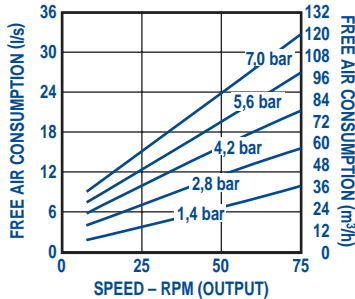
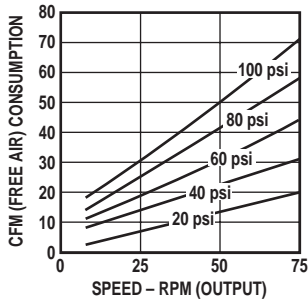

Torque vs. Speed

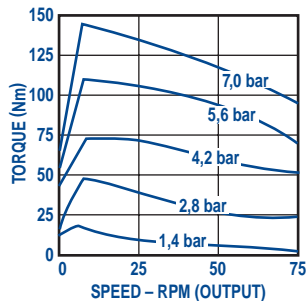
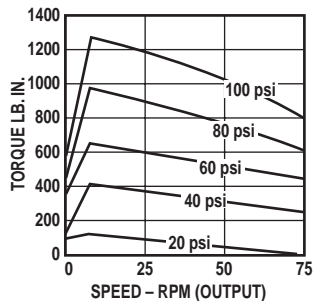

"C" Mounting 4AM-70C-CC40 / *4AM-70C-CG40 (standard shaft) / (opposite shaft)

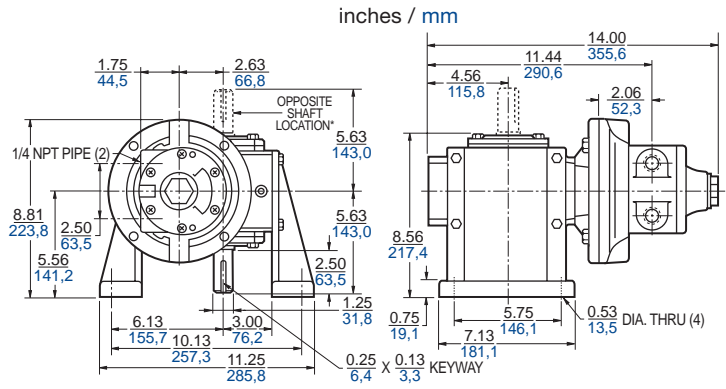

"D" Mounting 4AM-70C-CD40 / *4AM-70C-CH40 (standard shaft) / (opposite shaft)

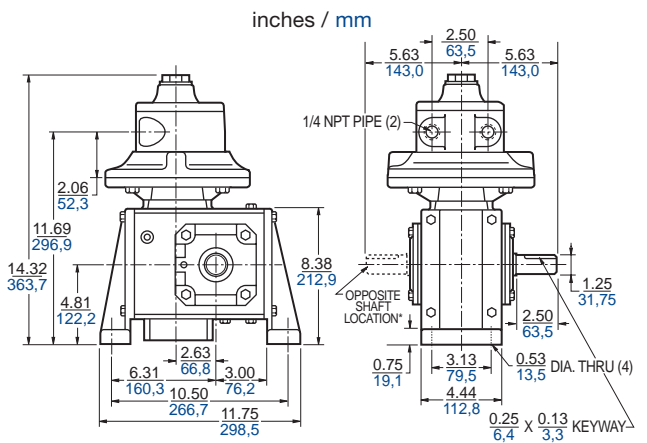



MODEL

4AM-70C-CB60

(8 Vanes, Reversible)

Net wt. for standard configuration
60 lbs. (27,0 kg)

FEATURES

- 60:1 gear reducer
- Base mounting
- Optional mountings and shaft locations available
- Metal muffler AC980 adds 2" height when installed

RECOMMENDED

- Filter AH103F
- Regulator AH104R
- Gauge AA806
- Lubricator AH105L
- Oil AD220 – 1 quart (.94 litres)
- Repair kit K280A (Air motor only)

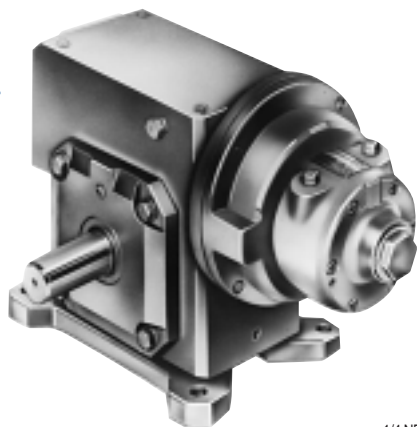

Max. allowable end thrust with 0 overhung load is 3545 lbs. (1595,3 kg) at 10 rpm to 2134 lbs. (960,3 kg) at 50 rpm. Max. overhung load on output shaft with 0 end thrust 1601 lbs. (720,5 kg).

"B" Mounting (photo)
4AM-70C-CB60 / *4AM-70C-CF60
(standard shaft) / (opposite shaft)

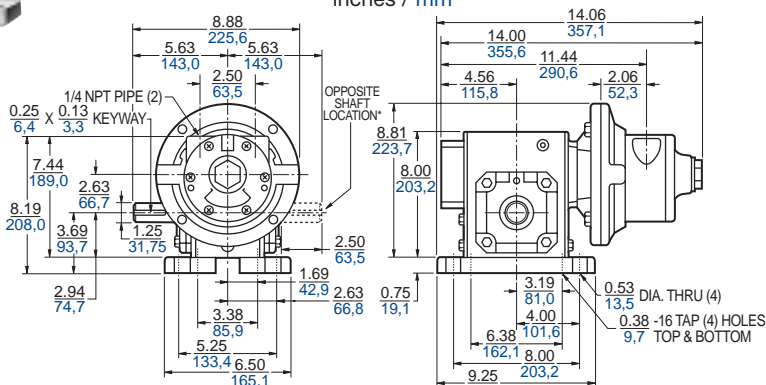

Output Power vs. Speed

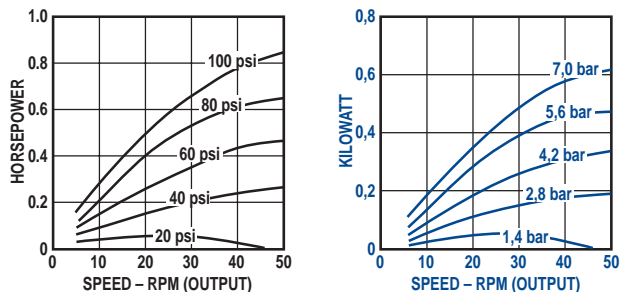

Torque vs. Speed

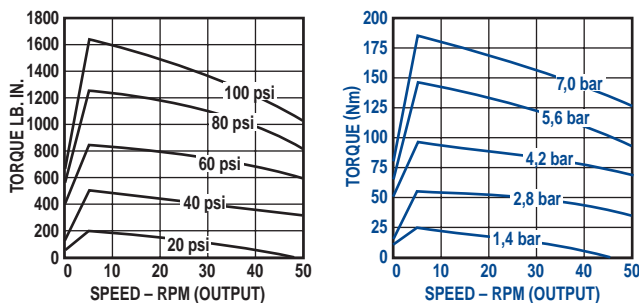

Air Consumption vs. Speed

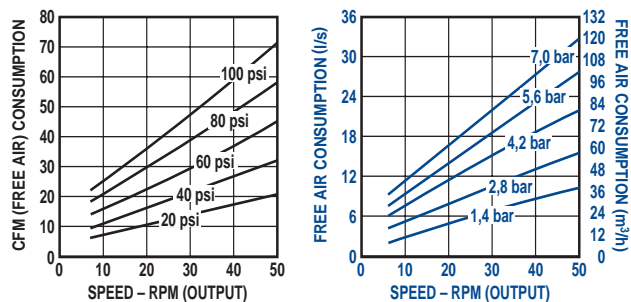

"C" Mounting
4AM-70C-CC60 / *4AM-70C-CG60
(standard shaft) / (opposite shaft)

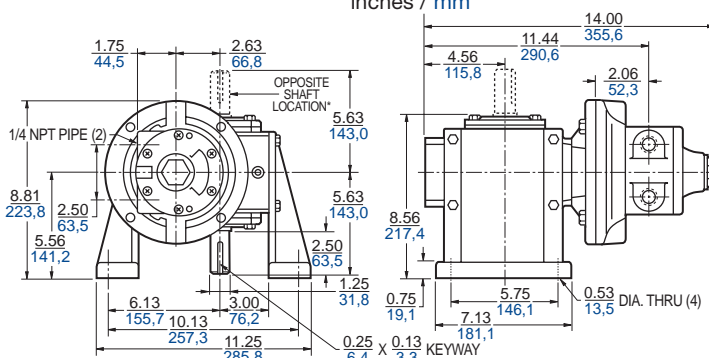

"D" Mounting
4AM-70C-CD60 / *4AM-70C-CH60
(standard shaft) / (opposite shaft)

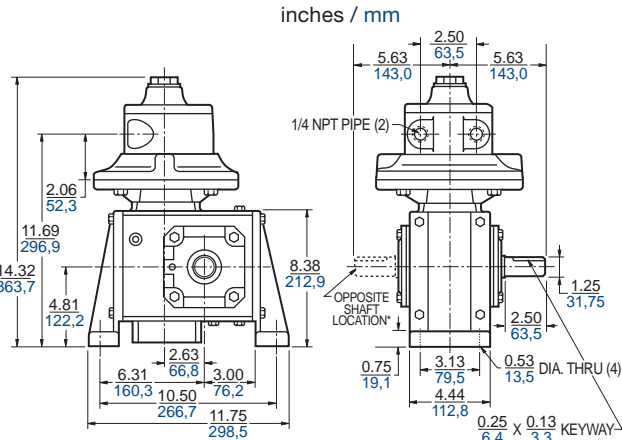



MODEL

6AM-22A-CB10

(8 Vanes, Reversible)

Net wt. for standard configuration
56 lbs. (25,2 kg)

FEATURES

- 10:1 gear reducer
- Base mounting
- Optional mountings and shaft locations available
- Muffler AC990 (not shown)

RECOMMENDED

- Filter AH106F
- Regulator AH107R
- Gauge AA806
- Lubricator AH108L
- Oil AD220 – 1 quart (.94 litres)
- Repair kit K281 (Air motor only)

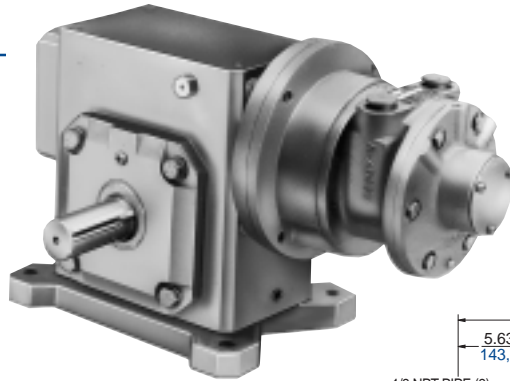

Max. allowable end thrust with 0 overhung load is 1640 lbs. (738,0 kg) at 60 rpm to 923 lbs. (415,4 kg) at 300 rpm. Max. overhung load on output shaft with 0 end thrust 1601 lbs. (720,5 kg).

“B” Mounting (photo)
6AM-22A-CB10 (standard shaft) / *6AM-22A-CF10 (opposite shaft)
inches / mm

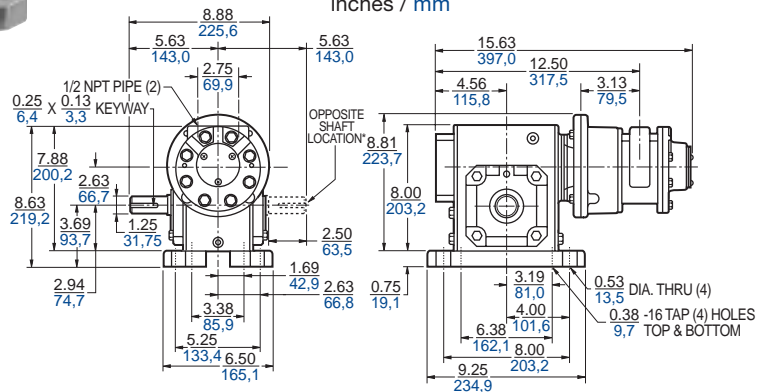

Output Power vs. Speed

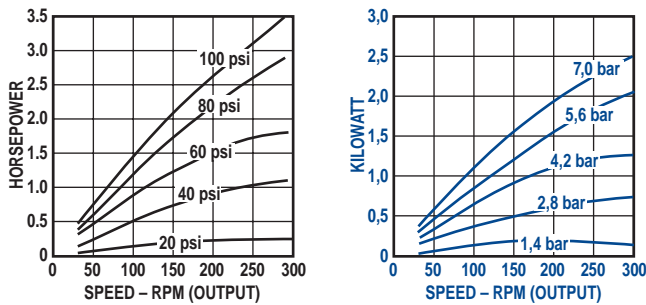

Torque vs. Speed

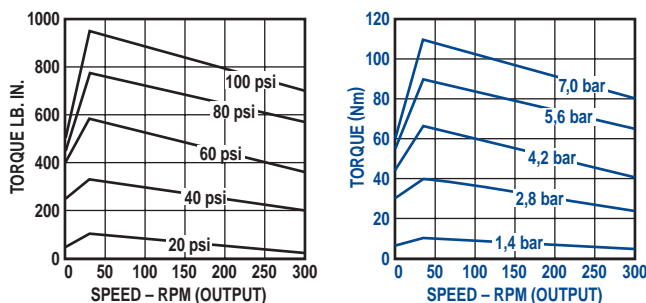

Air Consumption vs. Speed

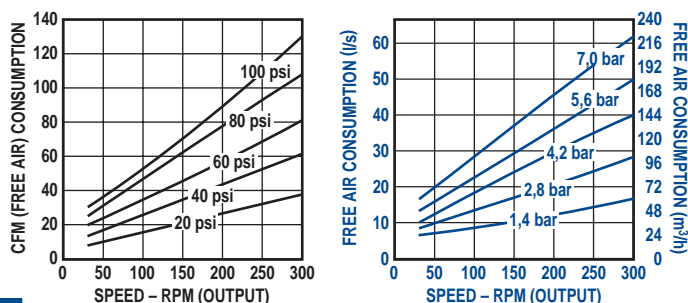

“C” Mounting

6AM-22A-CC10 (standard shaft) / *6AM-22A-CG10 (opposite shaft)
inches / mm

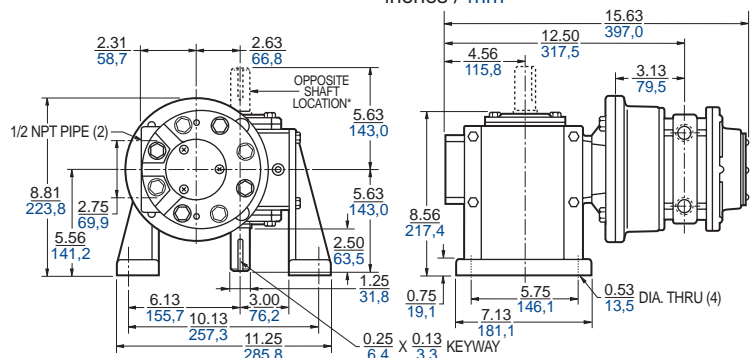

“D” Mounting

6AM-22A-CD10 (standard shaft) / *6AM-22A-CH10 (opposite shaft)
inches / mm

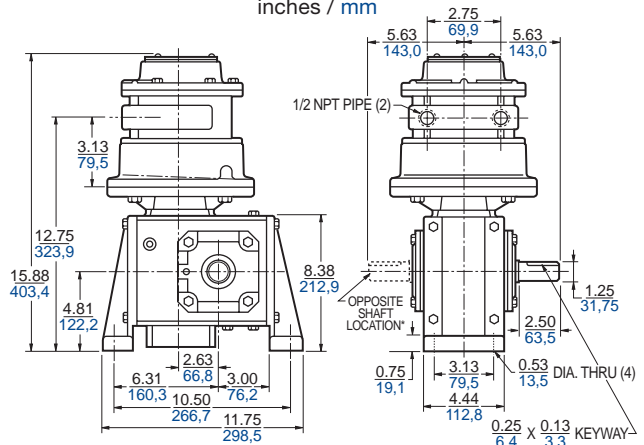



Air-Powered Gearmotors

6AM Series, 20:1 reduction, 225 – 1550 lbs. in. (30 – 180 Nm) torque at 15 rpm (minimum speed reduction)

MODEL

6AM-22A-DB20

(8 Vanes, Reversible)

Net wt. for standard configuration
100 lbs. (45,0 kg)

FEATURES

- 20:1 gear reducer
- Base mounting
- Optional mountings and shaft locations available
- Muffler AC990 (not shown)

RECOMMENDED

- Filter AH106F
- Regulator AH107R
- Gauge AA806
- Lubricator AH108L
- Oil AD220 – 1 quart (.94 litres)
- Repair kit K281 (Air motor only)

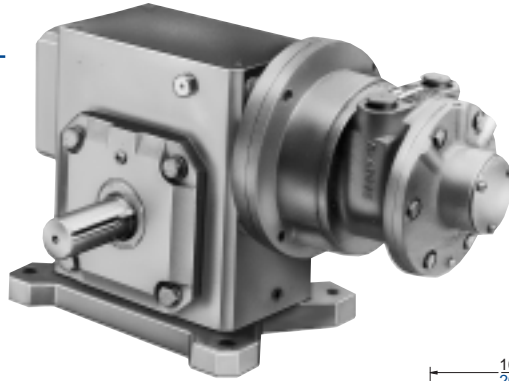

Max. allowable end thrust with 0 overhung load is 3552 lbs. (1598,4 kg) at 30 rpm to 2154 lbs. (969,3 kg) at 150 rpm. Max. overhung load on output shaft with 0 end thrust 2857 lbs. (1285,7 kg).

“B” Mounting (photo)
6AM-22A-DB20 / *6AM-22A-DF20
(standard shaft) / (opposite shaft)
inches / mm

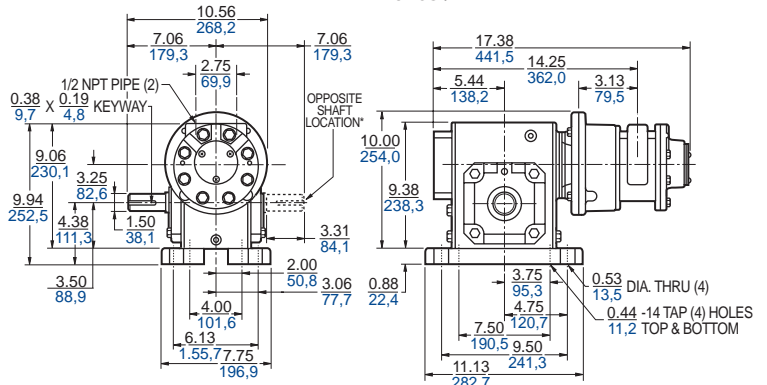

Output Power vs. Speed

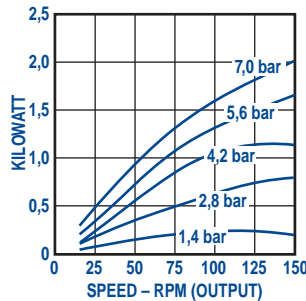
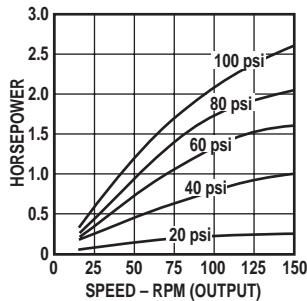

Torque vs. Speed

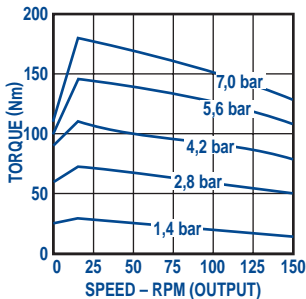
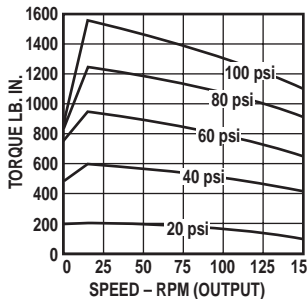

Air Consumption vs. Speed

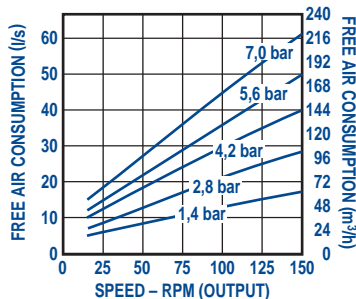
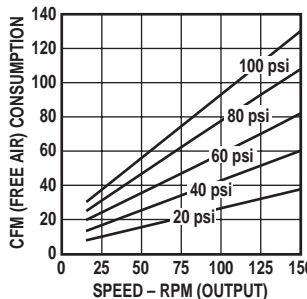

“C” Mounting
6AM-22A-DC20 / *6AM-22A-DG20
(standard shaft) / (opposite shaft)
inches / mm

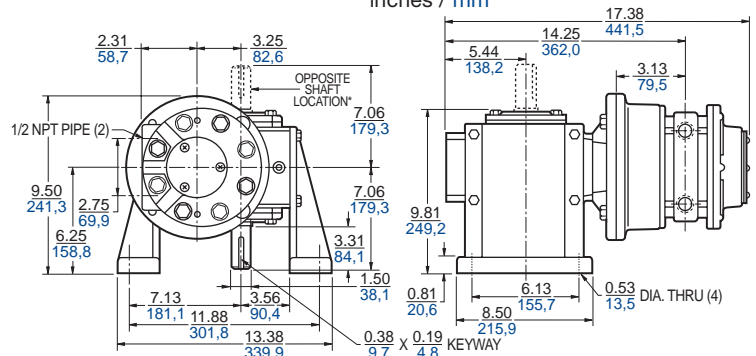

“D” Mounting
6AM-22A-DD20 / *6AM-22A-DH20
(standard shaft) / (opposite shaft)
inches / mm

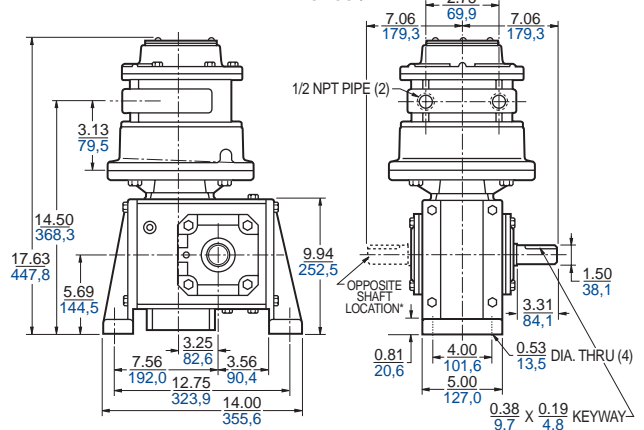



Air-Powered Gearmotors

6AM Series, 40:1 reduction, 250 – 2500 lbs. in. (30 – 275 Nm) torque at 8 rpm (minimum speed reduction)



MODEL

6AM-22A-GB40

(8 Vanes, Reversible)

Net wt. for standard configuration
104 lbs. (46,8 kg)

FEATURES

- 40:1 gear reducer
- Base mounting
- Optional mountings and shaft locations available
- Muffler AC990 (not shown)

RECOMMENDED

- Filter AH106F
- Regulator AH107R
- Gauge AA806
- Lubricator AH108L
- Oil AD220 – 1 quart (.94 litres)
- Repair kit K281 (Air motor only)

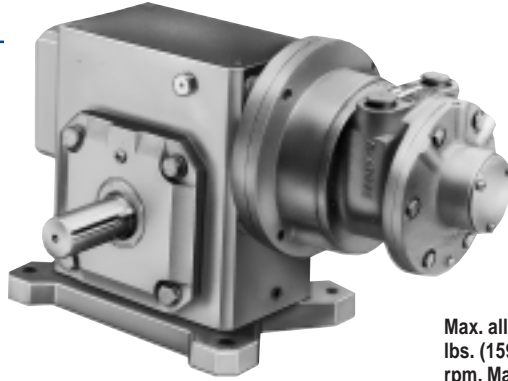

Max. allowable end thrust with 0 overhung load is 3552 lbs. (1598,4 kg) at 30 rpm to 2154 lbs. (969,3 kg) at 75 rpm. Max. overhung load on output shaft with 0 end thrust 2857 lbs. (1285,7 kg).

“B” Mounting (photo)
6AM-22A-GB40 / *6AM-22A-GF40
(standard shaft) / (opposite shaft)
inches / mm

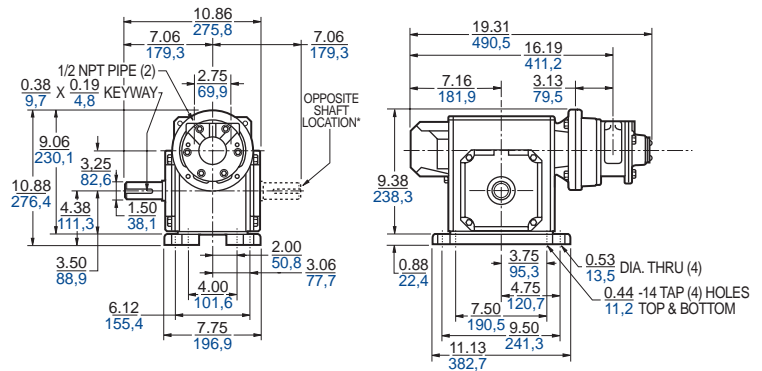

Output Power vs. Speed

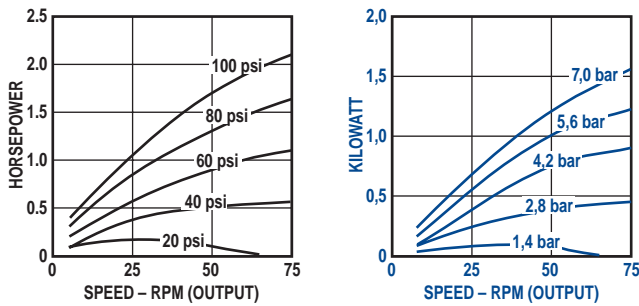

Torque vs. Speed

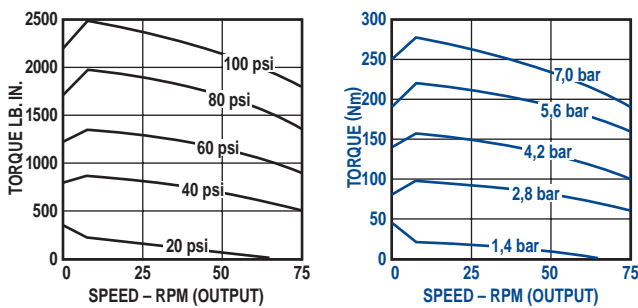

Air Consumption vs. Speed

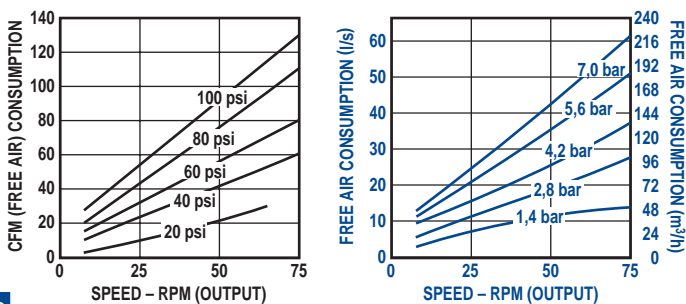

“C” Mounting
6AM-22A-GC40 / *6AM-22A-GG40
(standard shaft) / (opposite shaft)
inches / mm

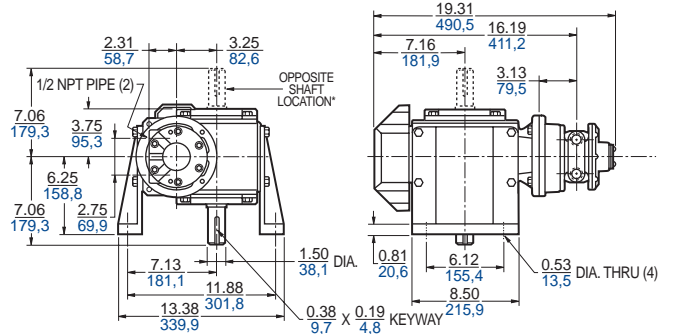



Air-Powered Gearmotors

8AM Series, 20:1 reduction, 400 – 2550 lbs. in. (50 – 290 Nm) torque at 15 rpm (minimum speed reduction)

MODEL

8AM-32A-FB20

(8 Vanes, Reversible)

Net wt. for standard configuration
111 lbs. (50,0 kg)

FEATURES

- 20:1 gear reducer
- Base mounting
- Optional mountings and shaft locations available
- Muffler AC990 (not shown)

RECOMMENDED

- Filter AH106F
- Regulator AH107R
- Gauge AA806
- Lubricator AH108L
- Muffler AG600 (above 1,000 rpm)
- Oil AD220 – 1 quart (.94 litres)
- Repair kit K282 (Air motor only)

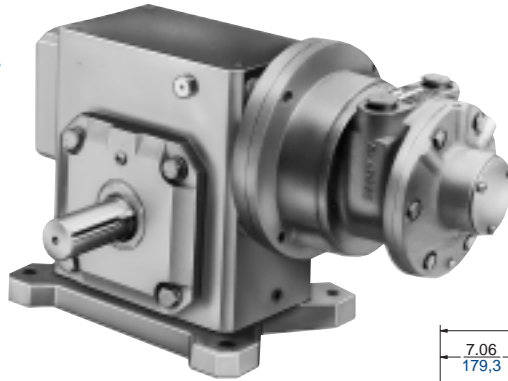

Max. allowable end thrust with 0 overhung load is 3552 lbs. (1598,4 kg) at 30 rpm to 2154 lbs. (969,3 kg) at 125 rpm. Max. overhung load on output shaft with 0 end thrust 2857 lbs. (1285,7 kg).

“B” Mounting (photo)

8AM-32A-FB20 (standard shaft) / *8AM-32A-FF20 (opposite shaft)

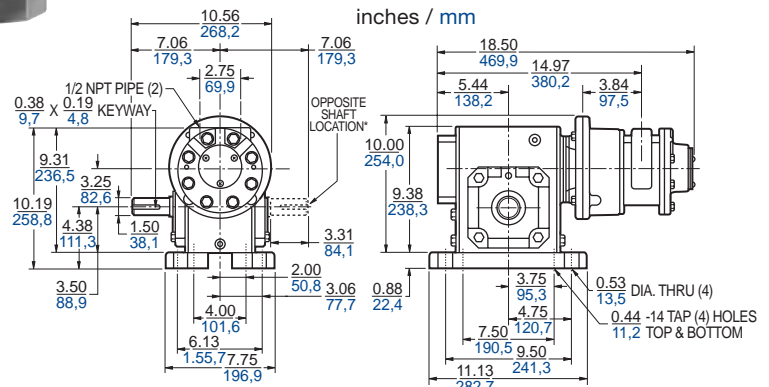

Output Power vs. Speed

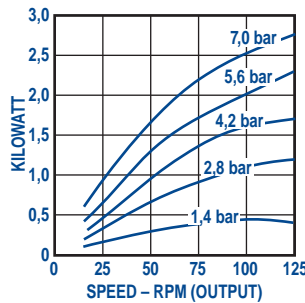
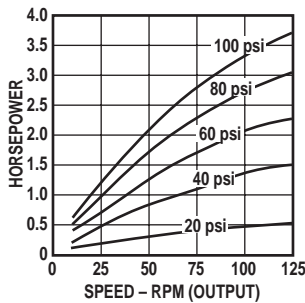

Torque vs. Speed

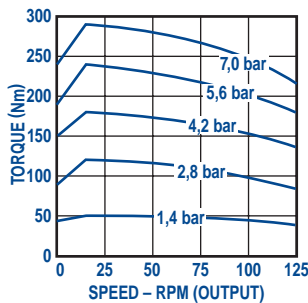
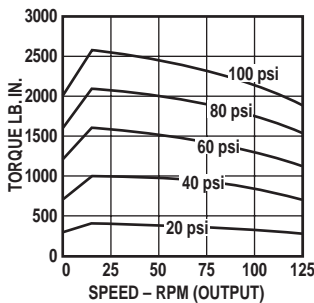

Air Consumption vs. Speed

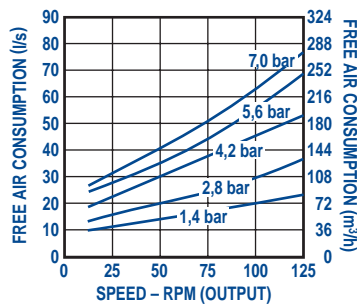
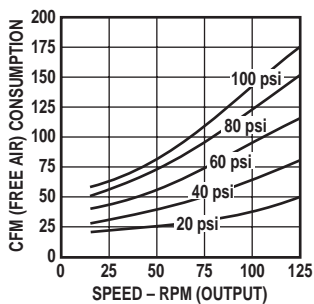

“C” Mounting

8AM-32A-FC20

inches / mm

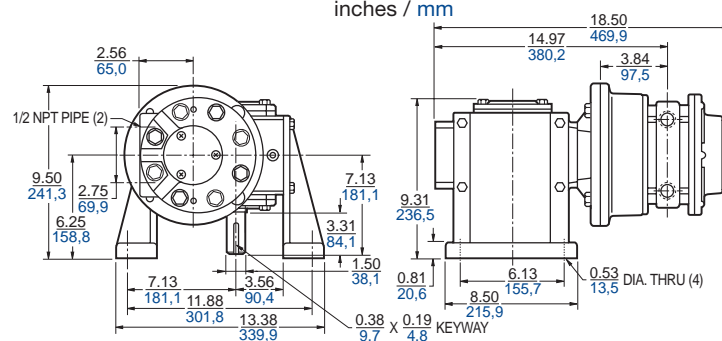

“D” Mounting

8AM-32A-FD20

inches / mm

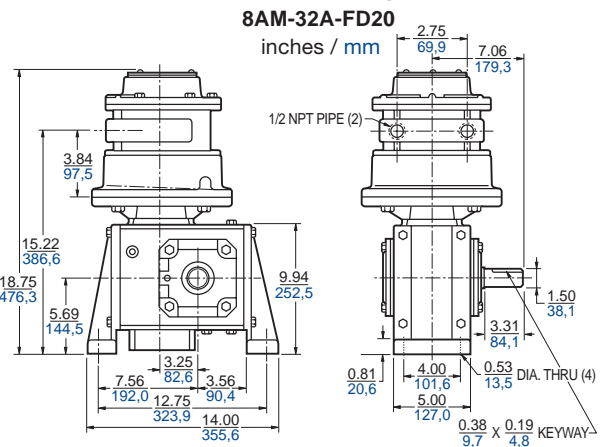



Air-Powered Gearmotors

16AM Series, 20:1 reduction, 775 – 5200 lbs. in. (90 – 580 Nm) torque at 15 rpm (minimum speed reduction)



MODEL

16AM-13-HB20

(6 Vanes, Reversible)

Net wt. for standard configuration
163 lbs. (73,4 kg)

FEATURES

- 20:1 gear reducer
- Base mounting
- Optional mountings and shaft locations available

RECOMMENDED

- Filter AH109F
- Regulator AH110R
- Gauge AA806
- Lubricator AH111L
- Muffler AG601
- Oil AD220 – 1 quart (.94 litres)
- Repair kit K213 (Air motor only)

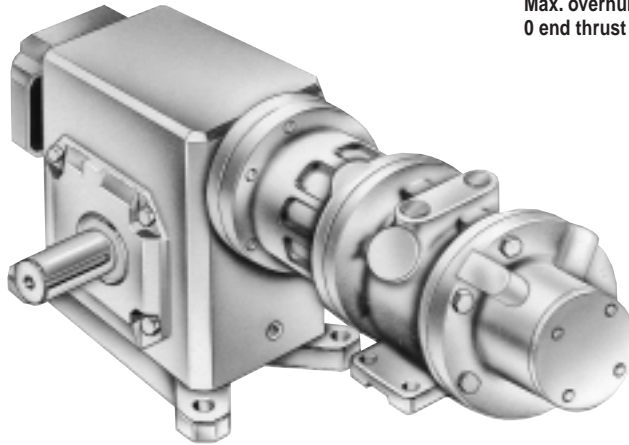

Max. allowable end thrust with 0 overhung load is 3552 lbs. (1598,4 kg) at 30 rpm to 2154 lbs. (969,3 kg) at 100 rpm. Max. overhung load on output shaft with 0 end thrust 2857 lbs. (1285,7 kg).

“B” Mounting (photo)

16AM-13-HB20 / *16AM-13-HF20
(standard shaft) / (opposite shaft)

inches / mm

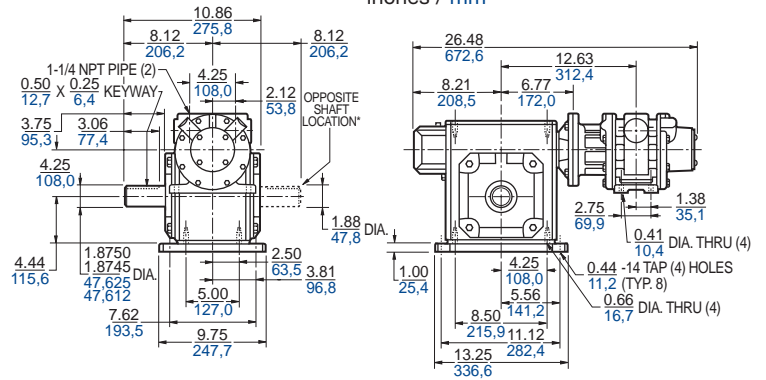

Output Power vs. Speed

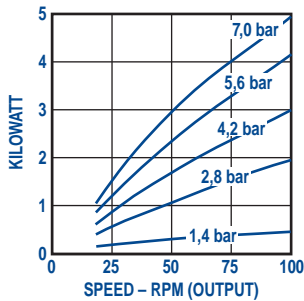
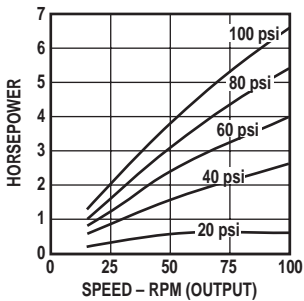

Torque vs. Speed

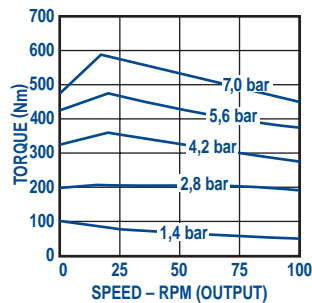
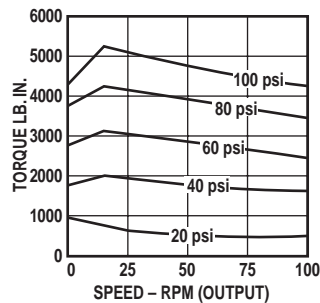

“C” Mounting

16AM-13-HC20 / *16AM-13-HG20
(standard shaft) / (opposite shaft)

inches / mm

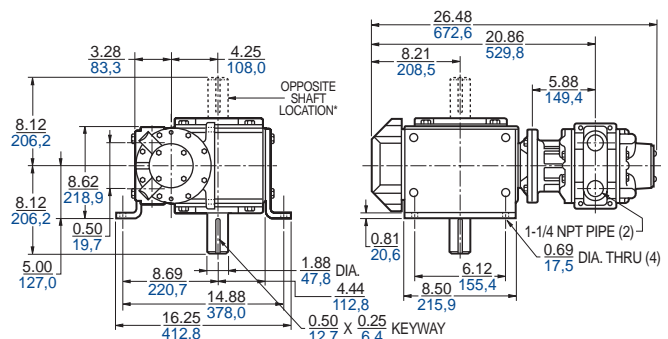

Air Consumption vs. Speed

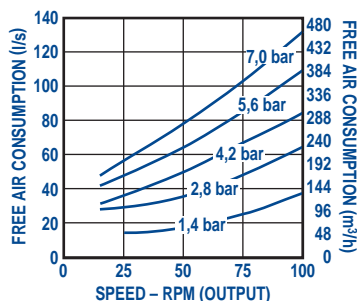
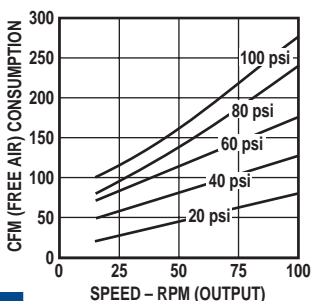



FILTERS

Gast Part Number	Port Size	Flow* SCFM	Used With	Dimensions - in. (mm)		
				A	B	C
+AH100F	1/8" NPTF	18	1AM/1UP/NL22	1.63 (41,4)	3.25 (82,6)	0.38 (9,7)
+AH103F	1/4" NPTF	50	2AM/4AM/NL32/NL42	2.75 (69,9)	5.84 (148,3)	0.69 (17,5)
+AH106F	1/2" NPTF	117	6AM/8AM/NL52	3.91 (99,3)	6.69 (169,9)	0.67 (17,0)
+AH109F	1" NPTF	365	16AM	4.75 (120,7)	10.44 (265,2)	1.25 (31,8)

*SCFM = Standard cubic feet per minute at 100 psi inlet and 5 psi pressure drop.

+Metal Bowl

REGULATORS

Gast Part Number	Port Size	Flow* SCFM	Used With	Dimensions - in. (mm)		
				A	B	C
AH101R	1/8" NPTF	11	1AM/1UP/NL22	1.63 (41,4)	2.38 (60,5)	0.38 (9,7)
AH104R	1/4" NPTF	50	2AM/4AM/NL32/NL42	2.44 (62,0)	4.00 (101,6)	1.54 (39,1)
AH107R	1/2" NPTF	130	6AM/8AM/NL52	3.50 (88,9)	5.36 (136,1)	1.50 (38,1)
AH110R	1" NPTF	360	16AM	4.25 (108,0)	5.69 (144,5)	2.38 (60,5)

*SCFM = Standard cubic feet per minute at 100 psi inlet, 80 psi secondary setting and 10 psi pressure drop.

LUBRICATORS

Gast Part Number	Port Size	Flow* SCFM	Used With	Dimensions - in. (mm)		
				A	B	C
+AH102L	1/8" NPTF	13	1AM/1UP	1.77 (45,0)	3.37 (85,6)	1.76 (44,7)
+AH105L	1/4" NPTF	20	2AM/4AM	2.56 (65,0)	5.75 (146,1)	1.85 (47,0)
+AH108L	1/2" NPTF	90	6AM & 8AM	3.91 (99,3)	6.69 (169,9)	1.88 (47,8)
+AH111L	1" NPTF	290	16AM	4.50 (114,3)	10.24 (260,1)	2.22 (56,4)

*SCFM = Standard cubic feet per minute at 100 psi inlet and 5 psi pressure drop.

+Metal Bowl

SPECIFICATIONS

Duty levels and applications may require different FRL's than recommended.

FILTER ELEMENT:

- 5 micron

PORT THREADS:

- All ports NPTF

GAUGE PORTS:

- Regulator Two ports – 1/4" NPTF, can be used as additional outlet ports, full flow 1/4", 1/8" NPTF for AH101R model.

PRESSURE RATING:

- Regulator Maximum primary pressure: 250 psi (17 bar)
- Secondary pressure range: Standard 2-125 psi (.14 to 8.6 bar)
- Temperature rating: -10°F to 175°F (-23°C to 80°C)

PRESSURE AND TEMPERATURE RATINGS:

- Polycarbonate Bowls
200 psi at 120°F (14 bar at 49°C) or less
100 psi at 175°F (7 bar at 80°C) or less

METAL BOWLS:

- 250 psi at 175°F (17 bar at 80°C) or less

BOWLS:

- Metal bowl

BOWL CAPACITY:

- 1 ounce for 1/8" model
- 5 ounce for 1/4" model
- 8 ounce for 1/2" model
- 32 ounce for 1" model

Filters

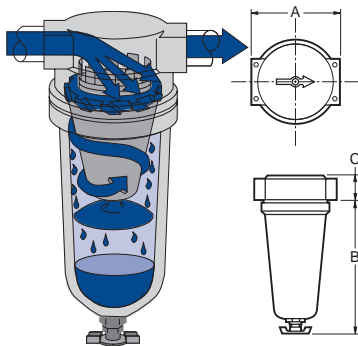

A filter helps ensure efficient operation by removing solid and liquid contaminants before they enter the air motor.

Regulators

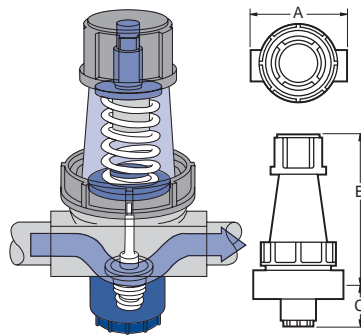

An air pressure regulator is necessary in most air motor applications to maintain a constant pressure regardless of the rise and fall of line pressure.

Lubricators

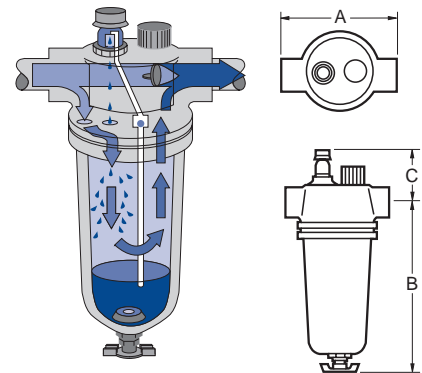

Mist lubricators provide uniform lubrication for the traditional lubricated style air motor. This results in reduced friction, extending the life of moving parts.



GAUGES

If a gauge is required for your Gast Regulator, please order as a separate item:

Gast Part No.	Used On	Description
AA806	AH104R AH107R AH110R	1/4" NPS, 0-160 psi

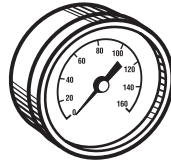

MUFFLERS

Gast Part Number	Used On	Dimensions - in (mm)		
		A	B	C
AF350 (Metal)	1AM/1UP/NL22	1.06 (27)	2.81 (71)	1/8" NPT
AC980 (Metal)	2AM/4AM/NL32/NL42	1.72 (44)	2.31 (59)	1/4" NPT
AC990 (Metal)	6AM/8AM	2.72 (69)	2.94 (75)	1/2" NPT
AG601* (Metal)	16AM	3.12 (79)	21.22 (539)	1 1/4" NPT

* Not included with 16AM series, but is recommended.

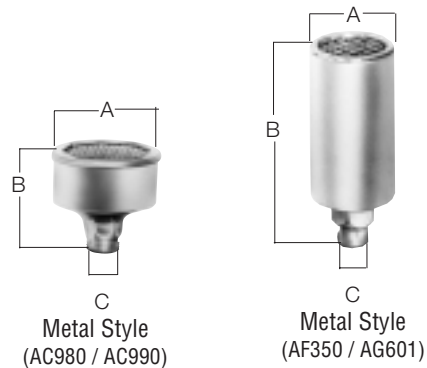

FOOT ASSEMBLIES FOR 1AM AND 1UP AIR MOTORS AND GEARMOTORS

FAST AND SIMPLE INSTALLATION

GAST now offers two foot assemblies in kit form:

AG585 for 1AM and 1UP Air Motors, kit includes foot, three mounting screws and instruction sheet.

AG586 for 1AM and 1UP Gearmotors, kit includes foot and three mounting screws.



AG585



AG586

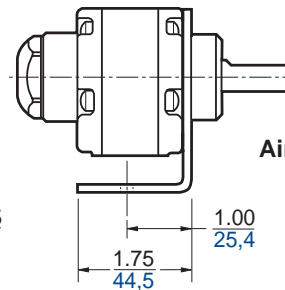
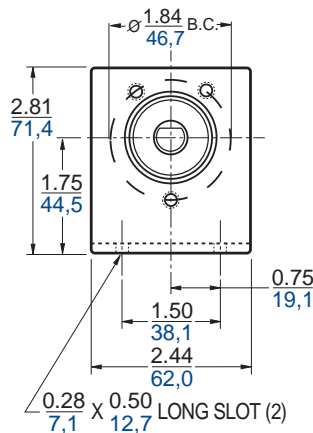

Air Motor Foot Assembly

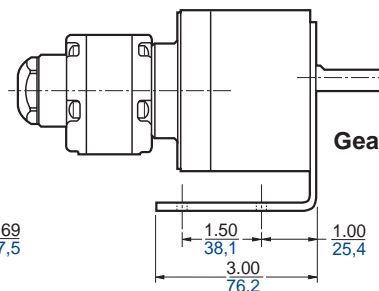
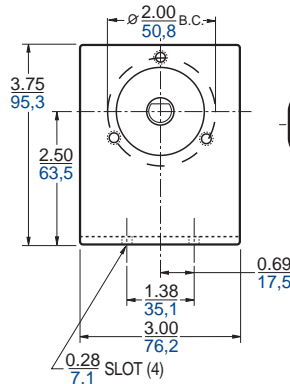

Gearmotor Foot Assembly