

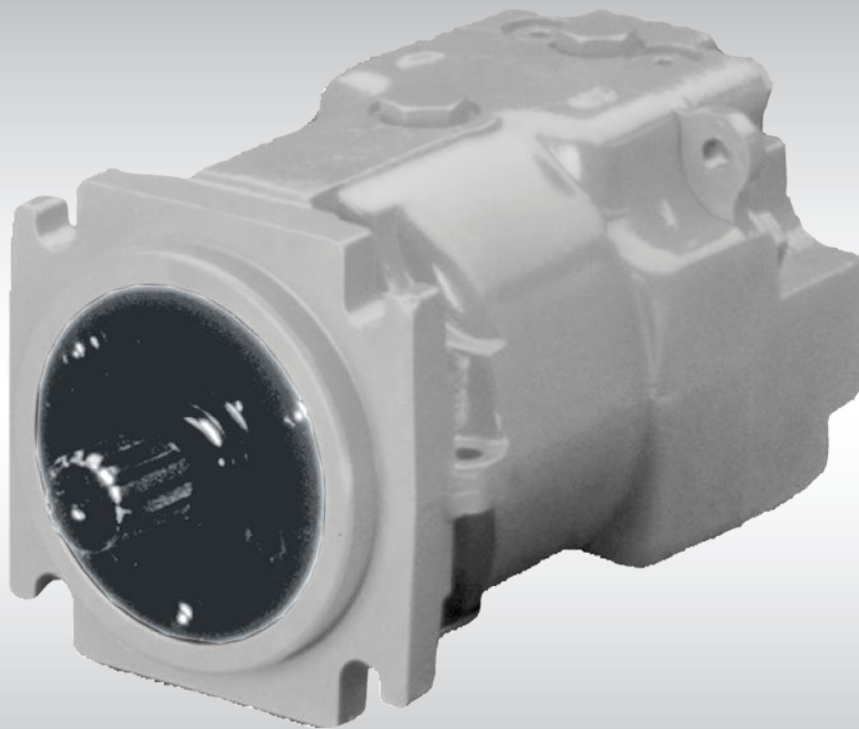

Technical Information

Series 90

Axial Piston Motors



Revision History*Table of Revisions*

Date	Changed	Rev
March 2014	connector corrections on page 18	FB
February 2014	Danfoss Layout	FA
November 2013	remove variable motors information	EA
November 2012	various updates	DC
September 2008	flange to shaft length dimension should be $[5.15 \pm 0.001]$	DB
April 2007	Remove allowable shaft loading data - consult factory	DA
March 2004	Fourth edition	D

Contents
General Description

Series 90 Family of Pumps and Motors.....	4
Fixed Displacement Motor, SAE Mount.....	4
Fixed Displacement Motor, Cartridge Mount.....	5
Pictorial Circuit Diagram.....	6
System Schematic.....	6

Technical Specifications

Overview.....	7
Features and Options.....	7
Specifications.....	7
Operating Parameters.....	7
Fluid Specifications.....	8

Operating Parameters

Overview.....	9
Speed Limits.....	9
System Pressure.....	9
Servo Pressure.....	9
Case Pressure.....	9
Hydraulic Fluids.....	10
Temperature and Viscosity.....	10

System Design Parameters

Fluid and Filtration.....	11
Independent Braking System.....	11
Reservoir.....	11
Overpressure Protection.....	11
Case Drain.....	12
Sizing Equations.....	12
Formulas.....	12
External Shaft Loading and Bearing Life.....	12
Applications with external shaft loads.....	13

Features and Options

Loop Flushing.....	15
Speed Sensor.....	17
Shaft Options.....	18

Installation Drawings

90K55 Fixed Motor Cartridge Mount.....	20
90M55 Fixed Motor SAE Mount.....	22
90K75 Fixed Motor Cartridge Mount.....	24
90M75 Fixed Motor SAE Mount.....	26
90M100 Fixed Motor SAE Mount.....	28
90M130 Fixed Motor SAE Mount.....	30

General Description
Series 90 Family of Pumps and Motors

Series 90 hydrostatic pumps and motors can be applied together or combined with other products in a system to transfer and control hydraulic power. They are intended for closed circuit applications.

Series 90 variable displacement pumps are compact, high power density units. All models utilize the parallel axial piston/slipper concept in conjunction with a tiltable swashplate to vary the pump's displacement. Reversing the angle of the swashplate reverses the flow of oil from the pump and thus reverses the direction of rotation of the motor output.

Series 90 pumps include an integral charge pump to provide system replenishing and cooling oil flow, as well as control fluid flow. They also feature a range of auxiliary mounting pads to accept auxiliary hydraulic pumps for use in complementary hydraulic systems. A complete family of control options is available to suit a variety of control systems (mechanical, hydraulic, electric).

Series 90 motors also use the parallel axial piston/slipper design in conjunction with a fixed swashplate. They can intake/discharge fluid through either port; they are bidirectional. They also include an optional loop flushing feature that provides additional cooling and cleaning of fluid in the working loop.

- Series 90 – advanced technology today
- Seven sizes of variable displacement pumps
- Four sizes of fixed displacement motors
- SAE and cartridge mount configurations
- Efficient axial piston design
- Proven reliability and performance
- Compact, lightweight
- Worldwide sales and service

Fixed Displacement Motor, SAE Mount

Cross section

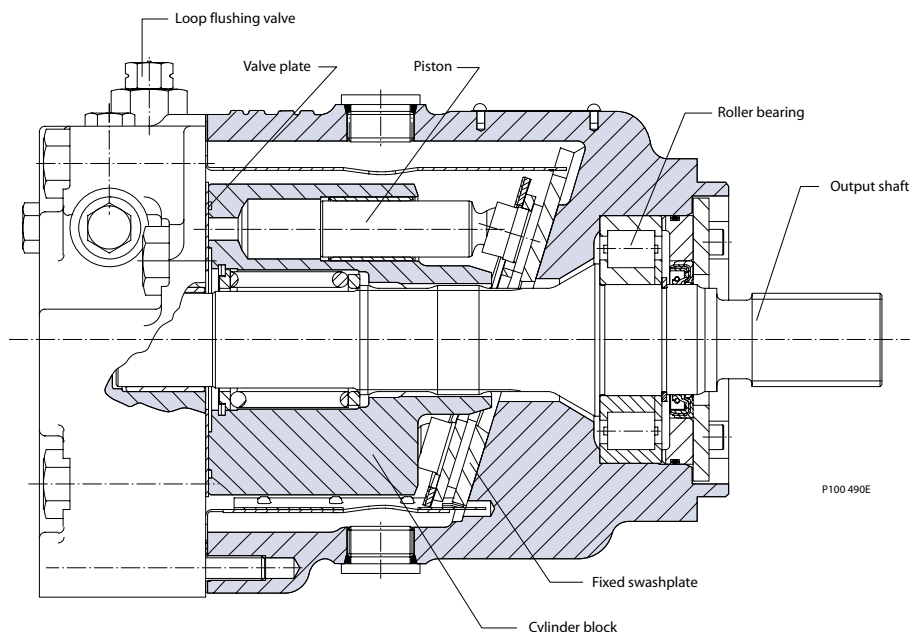

General Description

Name plate



Fixed Displacement Motor, Cartridge Mount

Cross section

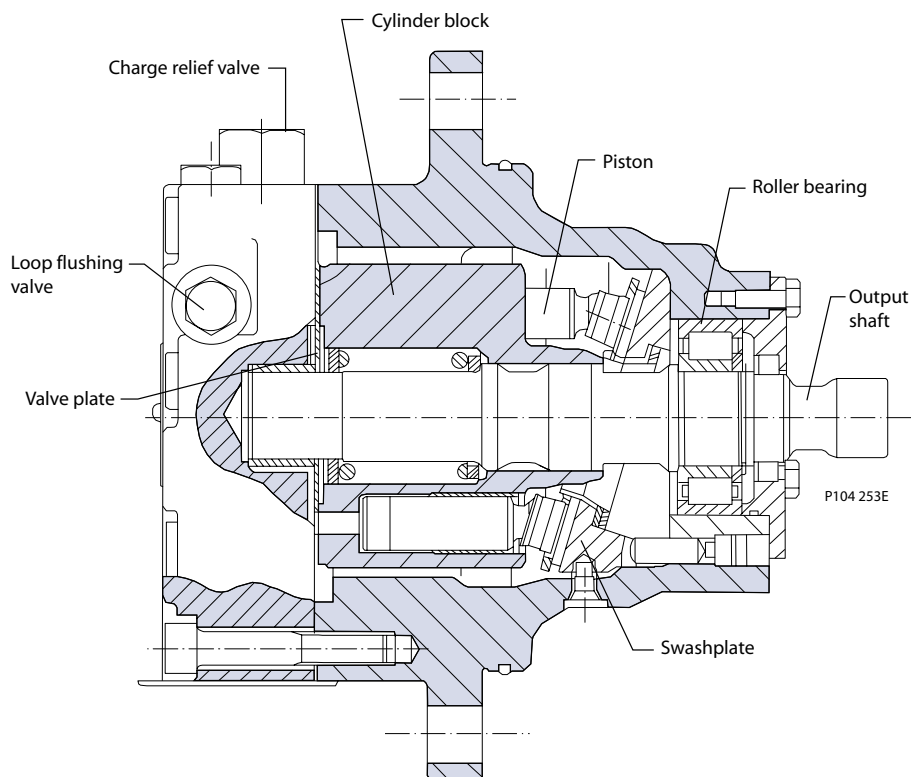

Name plate

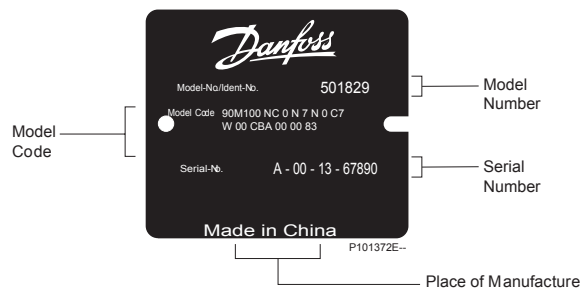

General Description

Pictorial Circuit Diagram

This configuration shows a hydrostatic transmission using a Series 90 axial piston variable displacement pump and a Series 90 fixed displacement motor.

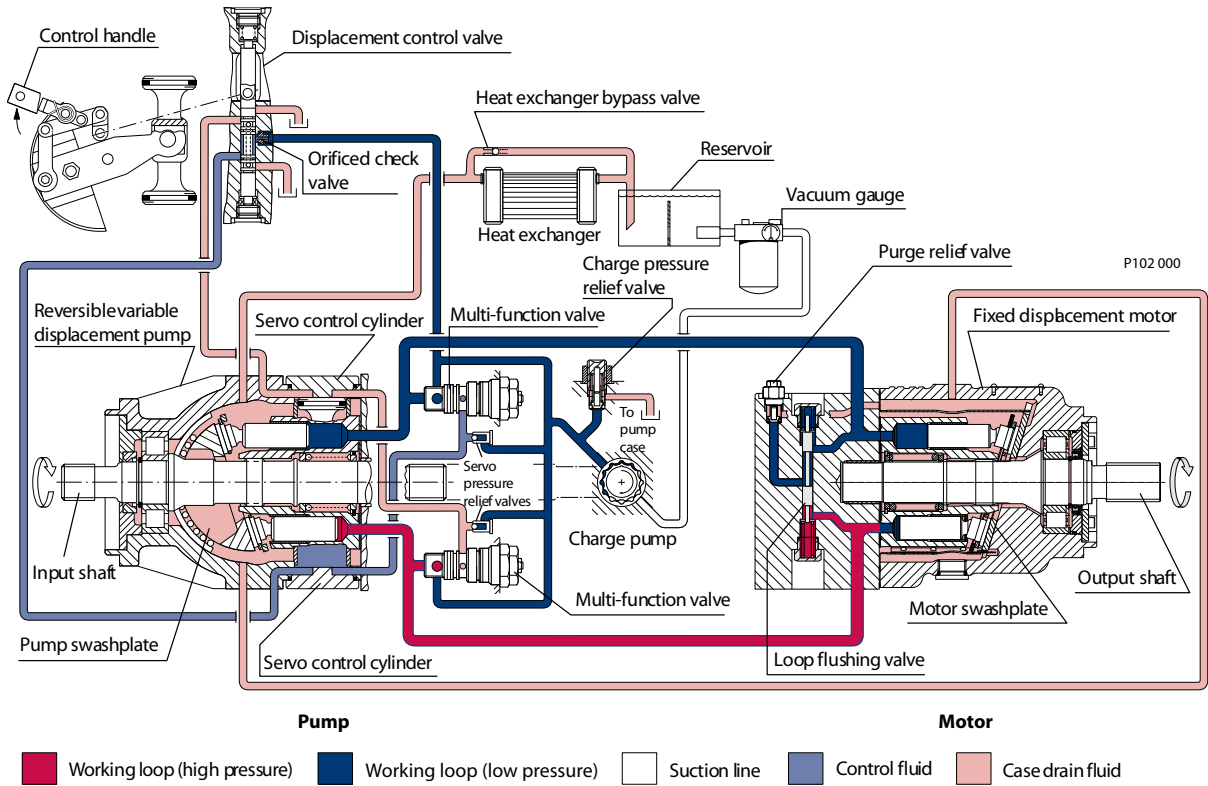

System Schematic

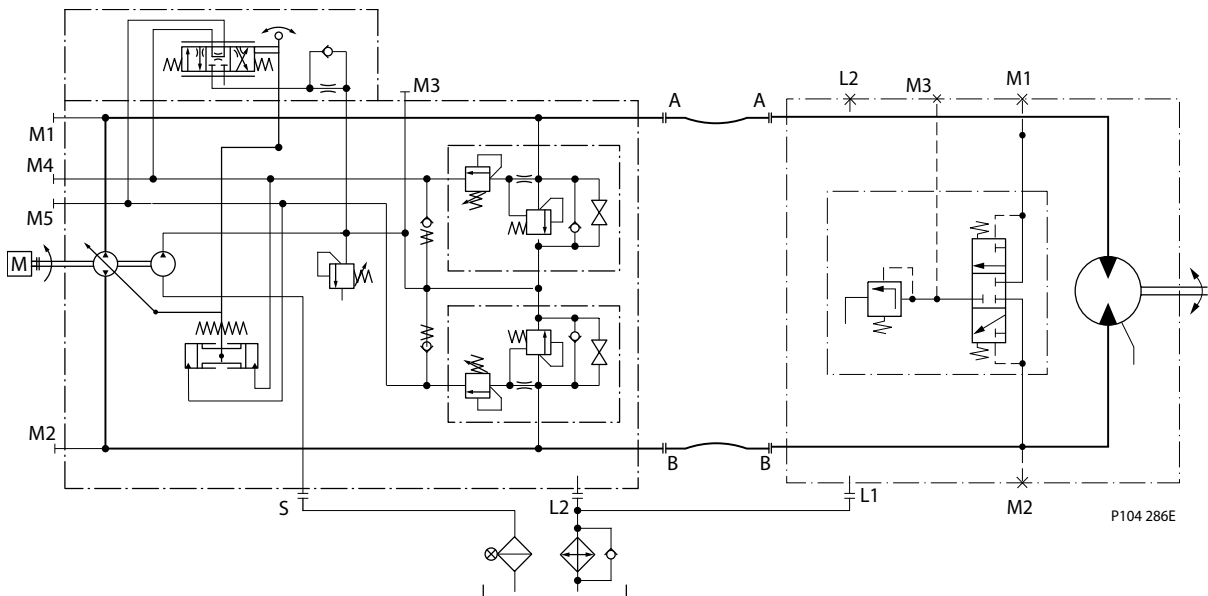

Technical Information Series 90 Axial Piston Motors

Technical Specifications

Overview

Specifications for the Series 90 motors are listed here for quick reference. For definitions and additional information, see [Operating Parameters](#) on page 7.

Features and Options

Motor type	In-line, axial piston, closed loop, positive displacement motors
Direction of rotation	Bi-directional, see outline drawings for rotation vs. flow direction information
Installation position	Discretionary: Housing must be filled with hydraulic fluid
Other system requirements	Independent braking system, overpressure protection, suitable reservoir, proper filtration

Parameter	055 MF	075 MF	100 MF	130 MF
Types of mounting (SAE flange size per SAE J744)	SAE C, cartridge	SAE C, cartridge	SAE C	SAE D
Port connections	Twin, axial	Twin, axial	Twin	Twin
Output shaft options	Spline, tapered, straight	Spline, tapered, straight	Spline, tapered, straight	Spline
Control options	—	—	—	—
Loop flushing	•	•	•	•
Speed sensor	o	o	o	o

• Standard

o Optional

— Not available / not applicable

Specifications

Parameter	055 MF	075 MF	100 MF	130 MF
Swashplate	Fixed	Fixed	Fixed	Fixed
Max. displacement cm ³ /rev [in ³ /rev]	55 [3.35]	75 [4.57]	100 [6.10]	130 [7.90]
Maximum corner power kW [hp]	187 [251]	237 [318]	292 [392]	354 [475]
Theoretical torque N·m/bar [lbf·in/1000 psi]	0.88 [530]	1.19 [730]	1.59 [970]	2.07 [1260]
Weight kg [lb]	SAE	22 [49]	26 [57]	34 [74]
	Cartridge	26 [57]	33 [72]	—
Mass moment of inertia kg·m ² [slug·ft ²]	0.0060 [0.0044]	0.0096 [0.0071]	0.0150 [0.0111]	0.0230 [0.0170]

Operating Parameters

Parameter	Unit	055 MF	075 MF	100 MF	130 MF
Speed limits					
Continuous (max. disp.)	min ⁻¹ (rpm)	3900	3600	3300	3100
Maximum (max. disp.)		4250	3950	3650	3400
Continuous (min. disp.)		—	—	—	—
Maximum (min. disp.)		—	—	—	—
System pressure					

Technical Information Series 90 Axial Piston Motors
Technical Specifications

Parameter	Unit	055 MF	075 MF	100 MF	130 MF
Continuous	bar [psi]	420 [6000]			
Maximum		480 [7000]			
Flow ratings					
Rated (max. disp., rated speed)	l/min [US gal/min]	215 [57]	270 [71]	330 [87]	403 [106]
Maximum (max. disp., max. speed)		234 [62]	296 [78]	365 [96]	442 [117]
Case pressure					
Continuous	bar [psi]	3 [44]			
Maximum (cold start)		5 [73]			

Fluid Specifications

Viscosity mm ² /sec (cSt) [SUS]	
Minimum	7 [49]
Continuous	12-80 [70-370]
Maximum	1600 [7500]
Temperature °C [°F] (measured at the hottest point in the system, usually the case drain)	
Minimum	-40 [-40]
Continuous	104 [220]
Maximum	115 [240]
Filtration	
Cleanliness	22/18/13 or better per ISO 4406
Efficiency (suction filtration)	$\beta_{35-45}=75$ ($\beta_{10} \geq 2$)
Efficiency (charge filtration)	$\beta_{15-20}=75$ ($\beta_{10} \geq 10$)
Recommended inlet screen size	100-125 μm [0.0039-0.0049 in]

Operating Parameters

Overview

Maintain operating parameters within prescribed limits during all operating conditions. This section defines operating limits given in the table [Operating Parameters](#) on page 7.

Speed Limits

Continuous speed is the highest input speed recommended at full power condition. Operating at or below this speed should yield satisfactory product life. In a machine propel application, maximum motor speed during unloaded, on - road travelling on level ground should not exceed this limit.

Maximum speed is the highest operating speed permitted. Exceeding maximum speed reduces product life and can cause loss of hydrostatic power and braking capacity. Never exceed the maximum speed limit under any operating conditions.

Consult *Pressure and speed limits BLN-9884*, when determining speed limits for a particular application.

Warning

Unintended vehicle or machine movement hazard.

Exceeding maximum speed may cause a loss of hydrostatic drive line power and braking capacity. You must provide a braking system, redundant to the hydrostatic transmission, sufficient to stop and hold the vehicle or machine in the event of hydrostatic drive power loss.

System Pressure

System pressure is the differential pressure between high pressure system ports. It is the dominant operating variable affecting hydraulic unit life. High system pressure, which results from high load, reduces expected life. Hydraulic unit life depends on the speed and normal operating, or weighted average, pressure that can only be determined from a duty cycle analysis.

Application pressure is the high pressure relief or pressure limiter setting normally defined within the order code of the pump. This is the applied system pressure at which the drive-line generates the maximum calculated pull or torque in the application.

Maximum working pressure is the highest recommended Application pressure. Maximum working pressure is not intended to be a continuous pressure. Propel systems with application pressures at, or below, this pressure should yield satisfactory unit life given proper component sizing.

Maximum pressure is the highest allowable Application pressure under any circumstance. Application pressures above maximum working Pressure will only be considered with duty cycle analysis and factory approval.

Pressure spikes are normal and must be considered when reviewing maximum working pressure.

Minimum low loop pressure must be maintained under all operating conditions to avoid cavitation.

All pressure limits are differential pressures referenced to low loop (charge) pressure. Subtract low loop pressure from gauge readings to compute the differential.

Servo Pressure

Servo pressure is the pressure in the Servo-system needed to position and hold the pump on stroke. It depends on system pressure and speed.

At **minimum** servo pressure the pump will run at reduced stroke depending on speed and pressure.

Minimum servo pressure at corner power holds the pump on full stroke at max speed and max pressure.

Maximum servo pressure is the highest pressure typically given by the charge pressure setting.

Case Pressure

Under normal operating conditions, the **rated case pressure** must not be exceeded. During cold start case pressure must be kept below maximum intermittent case pressure. Size drain plumbing accordingly.

Warning

Possible component damage or leakage

Operating Parameters

Operation with case pressure in excess of stated limits may damage seals, gaskets, and/or housings, causing external leakage. Performance may also be affected since charge and system pressure are additive to case pressure.

Hydraulic Fluids

Ratings and data are based on operating with hydraulic fluids containing oxidation, rust and foam inhibitors. These fluids must possess good thermal and hydrolytic stability to prevent wear, erosion, and corrosion of pump components. Never mix hydraulic fluids of different types.

Fire resistant fluids are also suitable at modified operating conditions. Please see Danfoss publication **520L0463** for more information. Refer to publication **520L0465** for information relating to biodegradable fluids.

Suitable Hydraulic fluids:

- Hydraulic fluids per DIN 51 524, 2-HLP,
- Hydraulic fluids per DIN 51 524, 3-HVLP,
- API CD, CE and CF engine fluids per SAE J183,
- M2C33F or G automatic transmission fluids (ATF),
- Dexron II (ATF), which meets the Allison C3- and Caterpillar TO-2 test,
- Agricultural multi purpose oil (STOU),
- Premium turbine oils.

Temperature and Viscosity

Temperature and viscosity requirements must be concurrently satisfied. The data shown in the table [Fluid Specifications](#) on page 8, assume petroleum-based fluids are used.

The high temperature limits apply at the hottest point in the transmission, which is normally the motor case drain. The system should generally be run at or below the **rated temperature**. The **maximum temperature** is based on material properties and should never be exceeded.

Cold oil will generally not affect the durability of the transmission components, but it may affect the ability of oil to flow and transmit power; therefore temperatures should remain 16 °C [30 °F] above the pour point of the hydraulic fluid. The **minimum temperature** relates to the physical properties of component materials.

For maximum unit efficiency and bearing life the fluid viscosity should remain in the **recommended operating range**. The **minimum viscosity** should be encountered only during brief occasions of maximum ambient temperature and severe duty cycle operation. The maximum viscosity should be encountered only at cold start.

Heat exchangers should be sized to keep the fluid within these limits. Testing to verify that these temperature limits are not exceeded is recommended.

System Design Parameters

Fluid and Filtration

To prevent premature wear, it is imperative that only clean fluid enter the hydrostatic transmission circuit. A filter capable of controlling the fluid cleanliness to ISO 4406 class 22/18/13 (SAE J1165) or better under normal operating conditions is recommended.

The filter may be located either on the inlet (suction filtration) or discharge (charge pressure filtration) side of the charge pump. The selection of a filter depends on a number of factors including the contaminant ingress rate, the generation of contaminants in the system, the required fluid cleanliness, and the desired maintenance interval. Filters are selected to meet the above requirements using rating parameters of efficiency and capacity.

Filter efficiency may be measured with a Beta ratio (β_X).

Filter β_X -ratio is a measure of filter efficiency defined by ISO 4572. It is defined as the ratio of the number of particles greater than a given diameter ("x" in microns) upstream of the filter to the number of these particles downstream of the filter.

For simple suction-filtered closed circuit transmissions and open circuit transmissions with return line filtration, a filter with a β -ratio within the range of $\beta_{35-45} = 75$ ($\beta_{10} \geq 2$) or better has been found to be satisfactory. For some open circuit systems, and closed circuits with cylinders being supplied from the same reservoir, a considerably higher filter efficiency is recommended. This also applies to systems with gears or clutches using a common reservoir. For these systems, a charge pressure or return filtration system with a filter β -ratio in the range of $\beta_{15-20} = 75$ ($\beta_{10} \geq 10$) or better is typically required.

Because each system is unique, only a thorough testing and evaluation program can fully validate the filtration system. Please see *Design Guidelines for Hydraulic Fluid Cleanliness 520L0467*, for more information.

Independent Braking System

Warning

Unintended vehicle or machine movement hazard.

The loss of hydrostatic drive line power, in any mode of operation (forward, neutral, or reverse) may cause the system to lose hydrostatic braking capacity. You must provide a braking system, redundant to the hydrostatic transmission, sufficient to stop and hold the vehicle or machine in the event of hydrostatic drive power loss.

Reservoir

The reservoir should be designed to accommodate maximum volume changes during all system operating modes and to promote de-aeration of the fluid as it passes through the tank.

A suggested minimum total reservoir volume is 5/8 of the maximum charge pump flow per minute with a minimum fluid volume equal to 1/2 of the maximum charge pump flow per minute. This allows 30 seconds fluid dwell for removing entrained air at the maximum return flow. This is usually adequate to allow for a closed reservoir (no breather) in most applications.

The reservoir outlet to the charge pump inlet should be above the bottom of the reservoir to take advantage of gravity separation and prevent large foreign particles from entering the charge inlet line. A 125 mm screen over the outlet port is recommended.

The reservoir inlet (fluid return) should be positioned so that flow to the reservoir is discharged below the normal fluid level, and also directed into the interior of the reservoir for maximum dwell and efficient de-aeration. A baffle (or baffles) between the reservoir inlet and outlet ports will promote de-aeration and reduce surging of the fluid.

Overpressure Protection

Series 90 motors (as well as other system components) have pressure limitations. As Series 90 motors are not equipped with overpressure protection, it is necessary that relief valves or pressure limiters are present elsewhere in the high pressure circuit to protect components from excessive pressures.

System Design Parameters

Series 90 pumps are designed with a sequenced pressure limiting system and high pressure relief valves. When the preset pressure is reached, the pressure limiter system acts to rapidly de-stroke the pump in order to limit the system pressure. For unusually rapid load application, the high pressure relief valve function is available to also limit the pressure level. Refer to publication *Series 90 Pumps Technical Information Manual 520L0603* for more information.

For systems with relief valves only, high pressure relief valves are intended for transient overpressure protection and are not intended for continuous pressure control. Operation over relief valves for extended periods of time may result in severe heat build up. High flows over relief valves may result in pressure levels exceeding the nominal valve setting and potential damage to system components.

Case Drain

A case drain line must be connected to one of the case outlets (L1 or L2) to return internal leakage and loop flushing flow to the system reservoir. The higher of the two case outlets should be used to promote complete filling of the case. Since case drain fluid is typically the hottest fluid in the system, it is advantageous to return this flow through the heat exchanger.

Sizing Equations

The following equations are helpful when sizing hydraulic motors. Generally, the sizing process is initiated by an evaluation of the machine system to determine the required motor speed and torque to perform the necessary work function. Refer to *Selection of drive line components BLN-9985*, for a more complete description of hydrostatic drive line sizing. First, the motor is sized to transmit the maximum required torque. The pump is then selected as a flow source to achieve the maximum motor speed.

Formulas

Based on SI units

$$\text{Input flow } Q = \frac{V_g \cdot n}{1000 \cdot \eta_v} \quad (\text{l/min})$$

$$\text{Output torque } M = \frac{V_g \cdot \Delta p \cdot \eta_m}{20 \cdot \pi} \quad (\text{N}\cdot\text{m})$$

$$\text{Output power } P = \frac{Q \cdot \Delta p \cdot \eta_t}{600} \quad (\text{kW})$$

$$\text{Motor speed } n = \frac{Q \cdot 1000 \cdot \eta_v}{V_g} \quad (\text{min}^{-1}(\text{rpm}))$$

Based on US units

$$\text{Input flow } Q = \frac{V_g \cdot n}{231 \cdot \eta_v} \quad (\text{US gal/min})$$

$$\text{Output torque } M = \frac{V_g \cdot \Delta p \cdot \eta_m}{2 \cdot \pi} \quad (\text{lb}\cdot\text{ft}\cdot\text{in})$$

$$\text{Output power } P = \frac{Q \cdot \Delta p \cdot \eta_t}{1714} \quad (\text{hp})$$

$$\text{Motor speed } n = \frac{Q \cdot 231 \cdot \eta_v}{V_g} \quad (\text{min}^{-1}(\text{rpm}))$$

Variables SI units [US units]

V_g	= Displacement per revolution	cm^3/rev [in^3/rev]
p_o	= Outlet pressure	bar [psi]
p_i	= Inlet pressure	bar [psi]
Δp	= $p_o - p_i$ (system pressure)	bar [psi]
n	= Speed	min^{-1} (rpm)
η_v	= Volumetric efficiency	
η_m	= Mechanical efficiency	
η_t	= Overall efficiency ($\eta_v \cdot \eta_m$)	

External Shaft Loading and Bearing Life

In vehicle propel drives with no external shaft loads where the system pressure is changing direction and magnitude regularly and the operating parameters are within the limits, the normal L20 bearing life (80% survival) will exceed the hydraulic life of the unit.

In non-propel drives such as vibratory drives, conveyor drives or fan drives, the operating pressure is often constant. These drives have unique duty cycles compared to a propel drive. In these types of applications a bearing life review is recommended.

In a bearing life analysis the following parameters are considered: Speed, pressure and external loads. Other factors that affect life include fluid type, viscosity and cleanliness.

System Design Parameters
Shaft loading parameters

Re	Maximum radial side load
Me	Maximum external moment
L	Distance from mounting flange to point of load

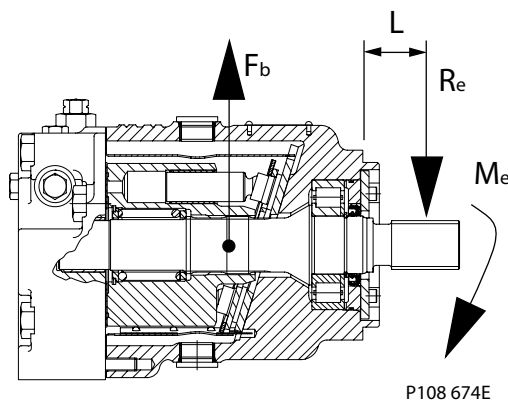
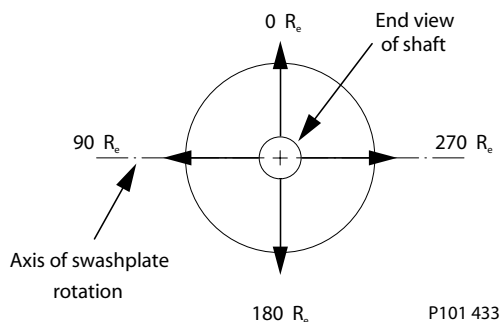
Shaft loading

External shaft load orientation

Applications with external shaft loads

Avoid external thrust (axial) loads in either direction whenever possible. Thrust loads could reduce the bearing life in applications with low delta system pressure or when present in combination with radial loading or bending moments.

External loads are found in applications where the motor is driven with a radial load on the shaft (i.e. belt or gear driven) as well as installations with misalignment or improper concentricity between the motor and drive coupling. All external loads will act to reduce the normal bearing life of a motor.

In applications where external radial shaft loads cannot be avoided, minimize the impact on bearing life by orienting the load to the 180° position as shown in the figure below when possible. Use tapered output shafts or clamped-type couplings where radial shaft loads are present.

Maximum allowable external shaft loads

Displacement	cm3	055	075	100	130
External moment Me	N·m	101	118	126	*

* No tapered shaft available

System Design Parameters

If continuous applied radial loads exceed 25% of the maximum allowable or thrust (axial) loads are present, contact your Danfoss representative for a bearing life evaluation.

Features and Options
Loop Flushing
 Warning

Unintended vehicle or machine movement hazard.

Excessive motor loop flushing flow may result in the inability to build required system pressure in some conditions. Maintain correct charge pressure under all conditions of operation to maintain pump control performance in hydrostatic systems.

An integral non-adjustable loop flushing valve is incorporated into Series 90 motors. Installations that require fluid to be removed from the low pressure side of the system circuit because of cooling requirements or contamination removal will benefit from loop flushing.

The integral loop flushing valve is equipped with an orificed charge pressure relief valve designed with a cracking pressure of 16 bar [232 psi]. Valves are available with several orifice sizes to meet the flushing flow requirements of all system operating conditions.

The total system charge pump flow should be of sufficient volume to accommodate:

- The number of motors in the system
- System efficiency under worst case conditions
- Pump control requirements
- External needs

Although charge pump sizing requires the consideration of many system variables, the following table gives a recommendation of what charge pump displacement may be required to accommodate the flushing flow of each available charge relief valve orifice.

Equation $Q_{\text{Flush}} = \frac{Q_{\text{Charge}} - Q_{\text{Leak}}}{2 \cdot k_{\text{Mo}}}$

- Where*
- Q_{Flush} = flushing flow per motor
 - Q_{Charge} = charge flow at operating speed
 - k_{Mo} = number of motors fed by one pump
 - Q_{Leak} = sum of external leakages including the following:
 - motor leakage
 - pump leakage + internal consumers: 8 l/min [2.11 US gal/min] for displacement control pumps
or for non-feedback controlled pumps at 200 bar [2900 psi]
 - external consumers (brakes, cylinders, other pumps)

Features and Options

Loop flushing flow curves

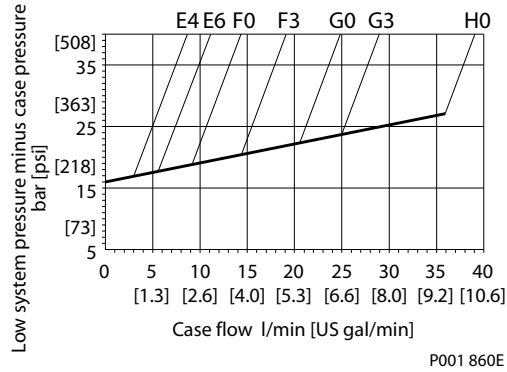

Recommended charge pump displacement

Orifice option	Charge pump displacement
E4	8 cm ³ [0.49 in ³]
E6	8 cm ³ [0.49 in ³]
F0	11 cm ³ [0.67 in ³]
F3	14 cm ³ [0.85 in ³]
G0	17 or 20 cm ³ [1.04 or 1.22 in ³]
G3	26 cm ³ [1.59 in ³]
H0	34, 37, or 65 cm ³ [2.07, 2.26, or 3.97 in ³]

Schematic diagram of loop flushing valve

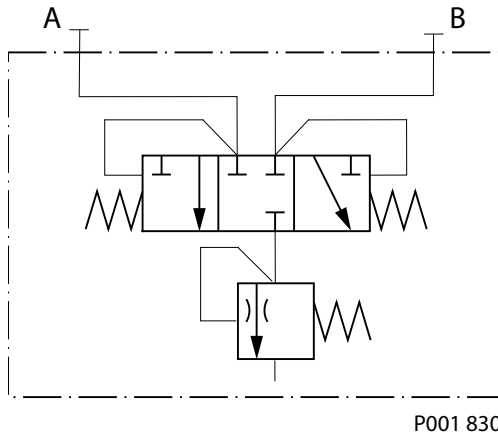

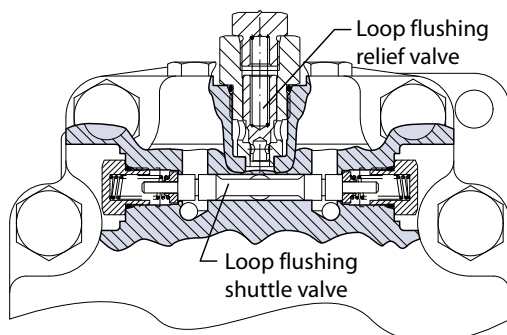
Features and Options
Loop flushing valve cross section

P101 426E

Speed Sensor

An optional speed sensor for direct measurement of speed is available. This sensor may also be used to sense the direction of rotation.

A special magnetic ring is pressed onto the outside diameter of the cylinder block and a Hall effect sensor is located in the motor housing. The sensor accepts supply voltage and outputs a digital pulse signal in response to the speed of the ring. The output changes its high/low state as the north and south poles of the permanently magnetized speed ring pass by the face of the sensor. The digital signal is generated at frequencies suitable for microprocessor based controls. The sensor is available with different connectors (see below).

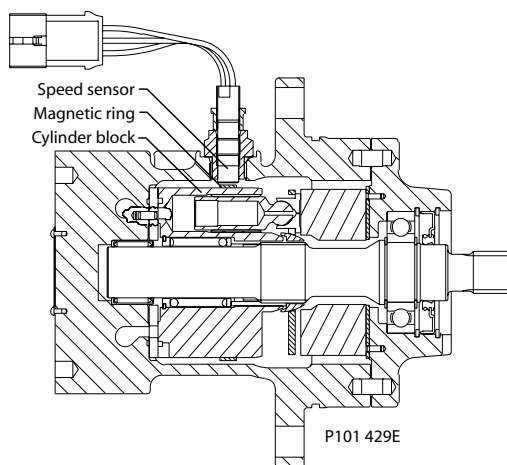
Speed Sensor

P101 429E

Specifications

Supply voltage*	4.5 to 8.5 VDC
Supply voltage (regulated)	15 VDC max.
Required current	12 mA at 5 VDC, 1 Hz
Max. current	20 mA at 5 VDC, 1 Hz
Max. frequency	15 kHz
Voltage output (high)	Supply -0.5 V min.
Voltage output (low)	0.5 V max.
Temperature range	-40° to 110°C [-40° to 230°F]

Features and Options

* Do not energize the 4.5 to 8.5 VDC sensor with 12 VDC battery voltage. Use a regulated power supply. If you need to energize the sensor with battery voltage, contact your Danfoss representative for a special sensor.

Pulse frequency

	055	075	100	130
Pulse per revolution	52	58	63	69

Speed sensor with Turck® Eurofast connector

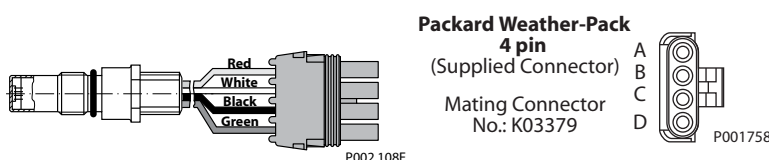
Speed sensor with Packard® Weather-Pack connector

Shaft Options

Series 90 motors are available with a variety of splined, straight keyed, and tapered shaft ends. Nominal shaft sizes and torque ratings are shown in the accompanying table.

Torque ratings assume no external radial loading. Continuous torque ratings for splined shafts are based on spline tooth wear, and assume the mating spline has a minimum hardness of Rc 55 and full spline depth with initial lubrication. Maximum torque ratings are based on fatigue and assume 200 000 load reversals. The permissible continuous torque may approach the maximum rating if the spline is immersed in circulating oil.

Series 90 shaft options

Shaft description	Option code	Torque rating			Frame size availability			
			N·m	in·lbf	055	075	100	130
21 tooth, 16/32 pitch spline	C6	Maximum: Continuous:	1130 384	10 000 3400	•	•	•	—
23 tooth, 16/32 pitch spline	C7	Maximum: Continuous:	1580 509	14 000 4500	—	•	•	—
27 tooth, 16/32 pitch spline	C8	Maximum: Continuous:	2938 814	26 000 7200	—	—	—	•
13 tooth, 8/16 pitch spline	F1	Maximum: Continuous:	1810 746	16 000 6600	—	—	•	•
13 tooth, 8/16 pitch spline (long)	F2	Maximum: Continuous:	1810 746	16 000 6600	—	—	•	—
14 tooth, 12/24 pitch spline	S1	Maximum: Continuous:	735 283	6500 2500	•	•	•	—
17 tooth, 12/24 pitch spline	S5	Maximum: Continuous:	1695 599	15 000 5300	—	—	•	—

Features and Options
Series 90 shaft options (continued)

Shaft description	Option code	Torque rating			Frame size availability			
			N•m	in•lbf	055	075	100	130
34.9 mm [1.374 in] dia. straight keyed	K1	Maximum:	768	6800	•	—	—	—
38.07 mm [1.499 in] dia. straight keyed	K2	Maximum:	1130	10 000	—	•	—	—
44.42 mm [1.749 in] dia. straight keyed	K3	Maximum:	1582	14 000	—	—	•	—

• Available

— Not available

Recommended mating splines for Series 90 splined output shafts should be in accordance with ANSI B92.1 Class 5. Danfoss external splines are modified class 5 fillet root side fit. The external spline major diameter and circular tooth thickness dimensions are reduced to assure a clearance fit with the mating spline. Contact your Danfoss representative for other splined shaft options.

Installation Drawings

90K55 Fixed Motor Cartridge Mount

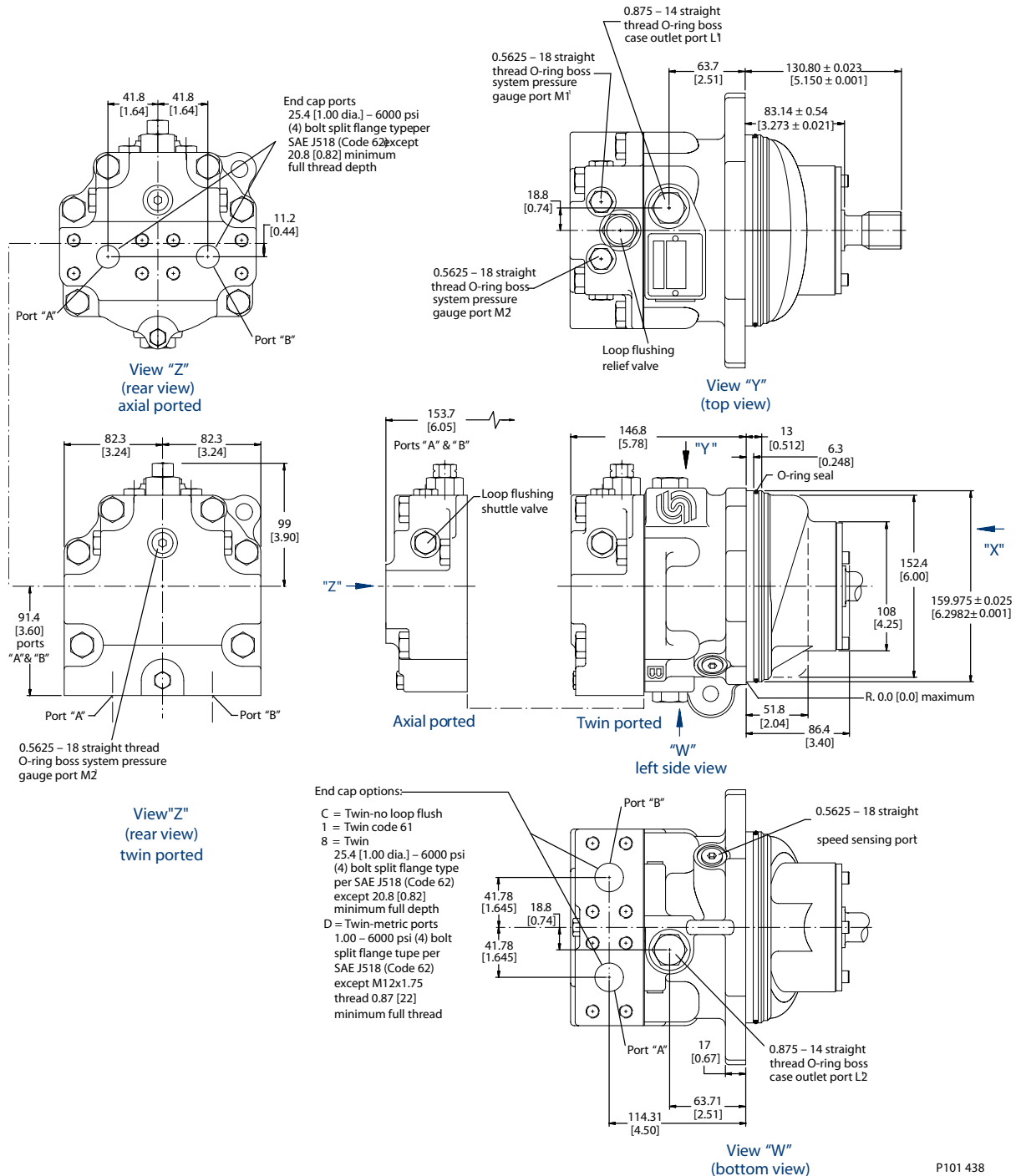

P101 438

All SAE straight thread O-rings ports per SAE J1926 (fittings per SAE 514). Shaft rotation is determined by viewing motor from output shaft end. Contact your Danfoss representative for specific installation drawings

Installation Drawings

Splined output shaft options

Output shaft option	Shaft diameter T	Full spline length U	Major diameter V	Pitch diameter W	Number of teeth Y	Pitch Z
S1	24.9 [0.98]	27.9 [1.10]	31.13 [1.2258]	29.634 [1.1667]	14	12/24
C6	29 [1.14]	32.5 [1.28]	34.42 [1.3550]	33.338 [1.3125]	21	16/32

Flow direction

Shaft rotation	Flow direction	
	Port "A"	Port "B"
Clockwise (CW)	Out	In
Counterclockwise (CCW)	In	Out

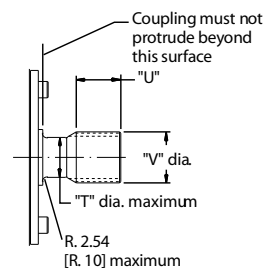
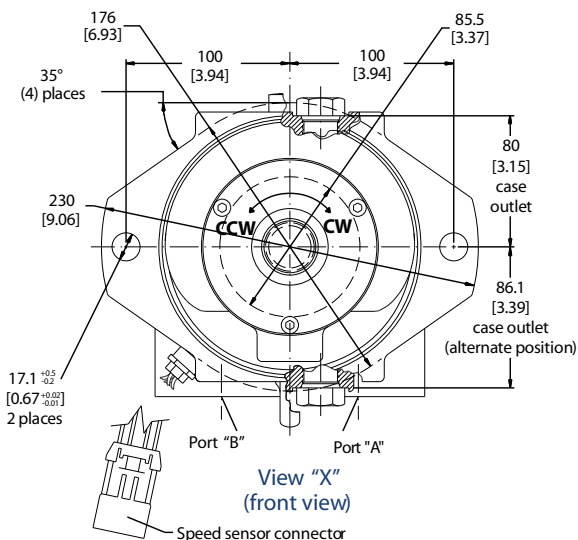

Splined shaft options (see tables)

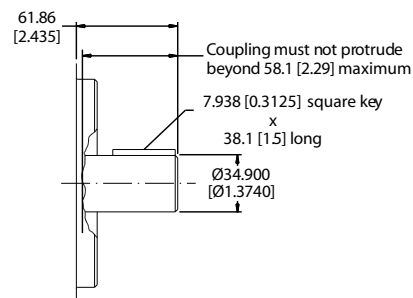

Shaft option K1

Installation Drawings

90M55 Fixed Motor SAE Mount

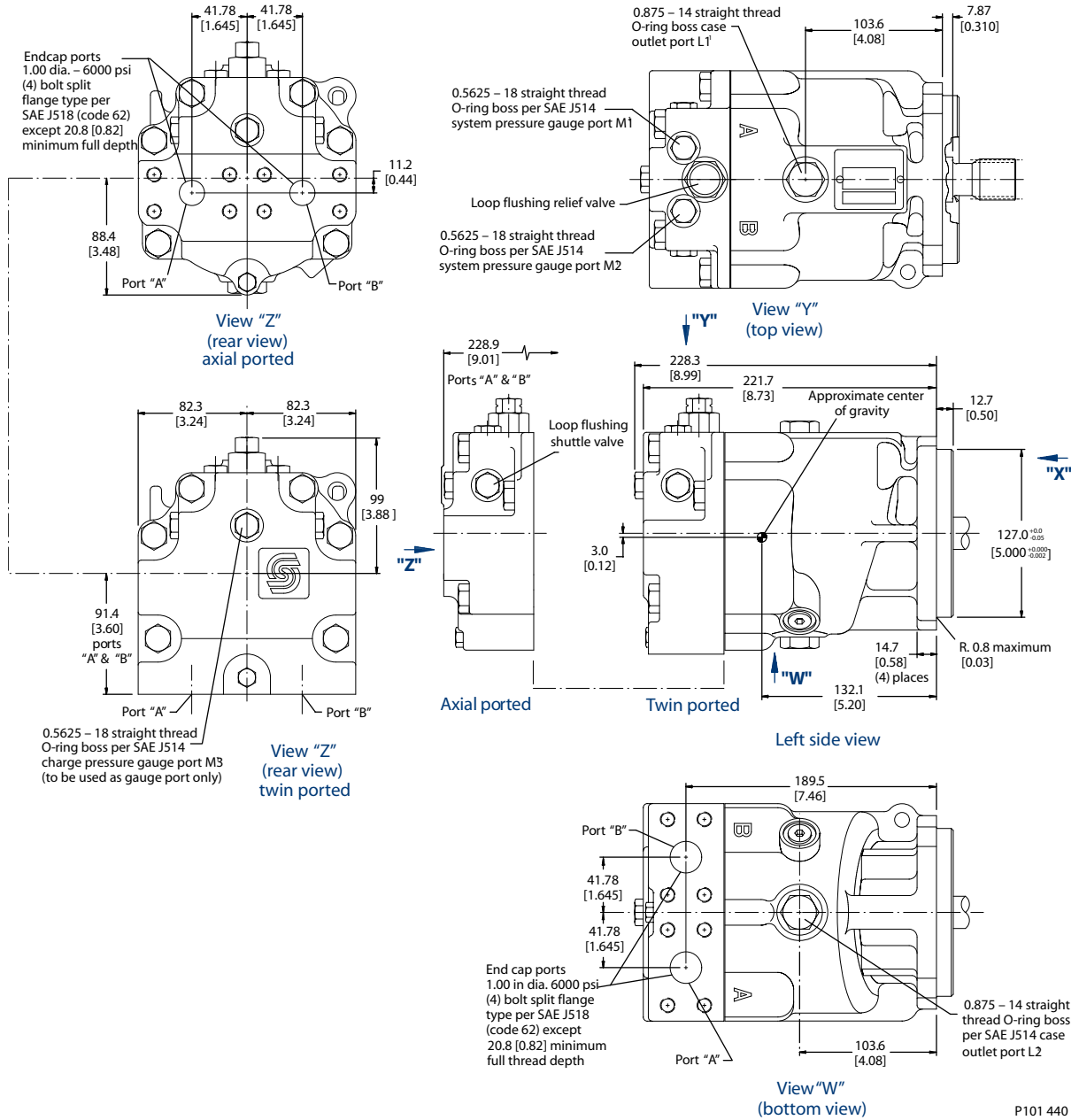

P101 440

All SAE straight thread O-rings ports per SAE J1926 (fittings per SAE 514). Shaft rotation is determined by viewing motor from output shaft end. Contact your Danfoss representative for specific installation drawings

Spined output shaft options

Output shaft option	Shaft diameter T	Full spline length U	Major diameter V	Pitch diameter W	Number of teeth Y	Pitch Z
S1	24.9 [0.98]	27.9 [1.10]	31.13 [1.2258]	29.634 [1.1667]	14	12/24

Installation Drawings

Splined output shaft options (continued)

Output shaft option	Shaft diameter T	Full spline length U	Major diameter V	Pitch diameter W	Number of teeth Y	Pitch Z
C6	29 [1.14]	32.5 [1.28]	34.42 [1.3550]	33.338 [1.3125]	21	16/32

Flow direction

Shaft rotation	Flow direction	
	Port "A"	Port "B"
Clockwise (CW)	Out	In
Counterclockwise (CCW)	In	Out

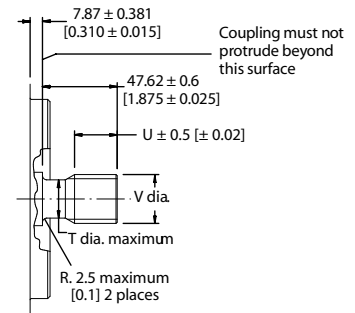
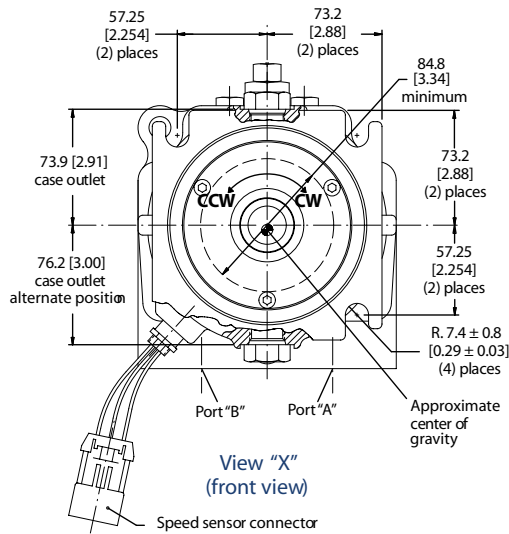

Splined shaft options (see table)

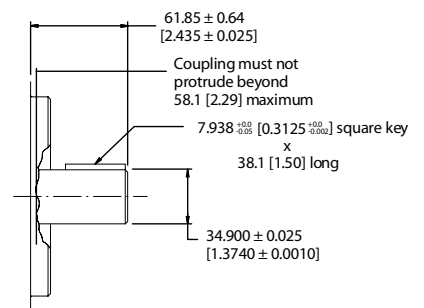

Shaft option: K1 (keyed)

Installation Drawings

90K75 Fixed Motor Cartridge Mount

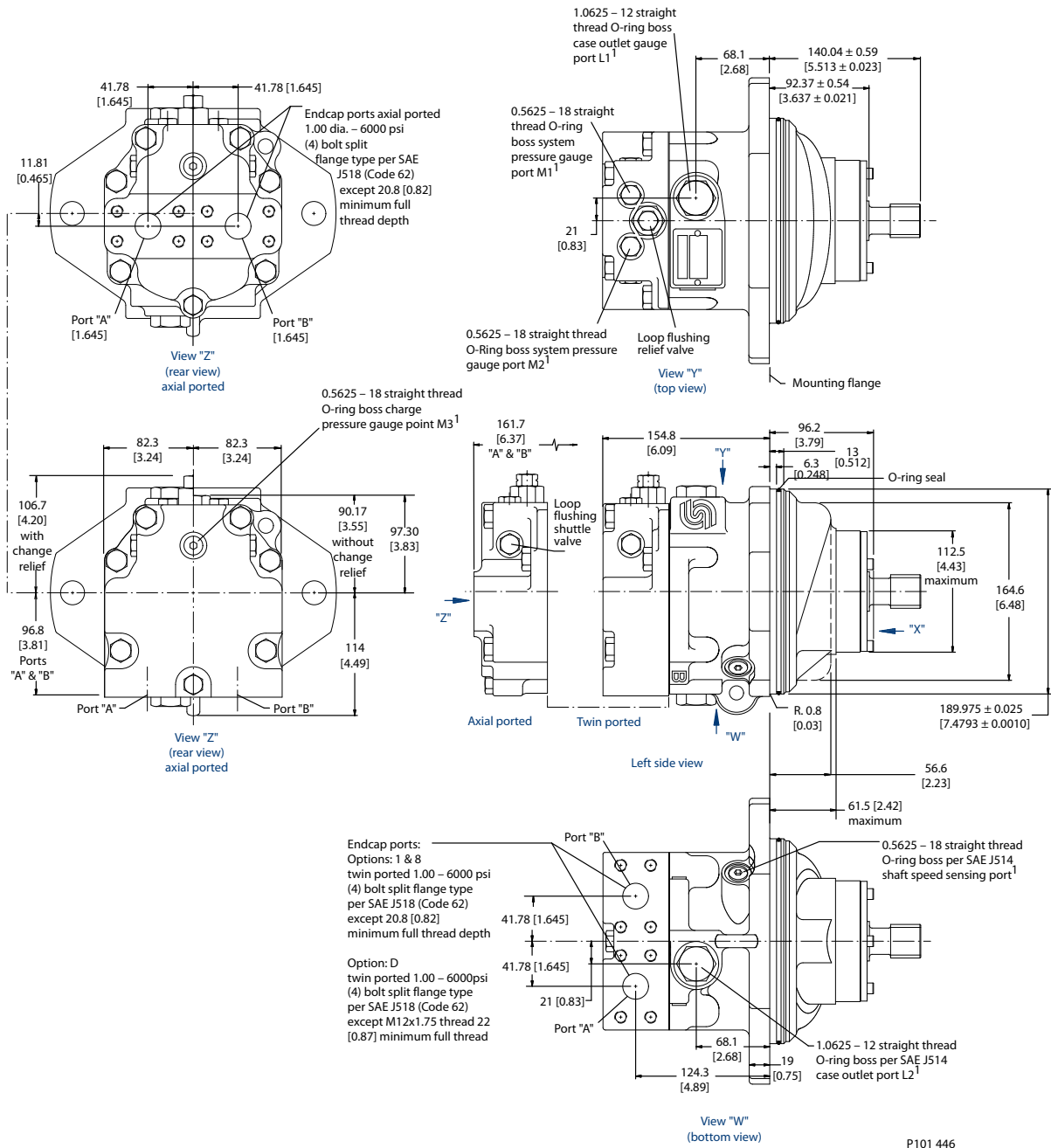

All SAE straight thread O-rings ports per SAE J1926 (fittings per SAE 514). Shaft rotation is determined by viewing motor from output shaft end. Contact your Danfoss representative for specific installation drawings

Spined output shaft options

Output shaft option	Shaft diameter T	Full spline length U	Major diameter V	Pitch diameter W	Number of teeth Y	Pitch Z
S1	29.9	27.9	31.13	29.634	14	12/24

Installation Drawings

Splined output shaft options (continued)

Output shaft option	Shaft diameter T	Full spline length U	Major diameter V	Pitch diameter W	Number of teeth Y	Pitch Z
	[0.98]	[1.10]	[1.2258]	[1.1667]		
C6	29 [1.14]	32.5 [1.28]	24.42 [1.3550]	33.338 [1.3125]	21	16/32
C7	32.3 [1.27]	34.8 [1.37]	37.59 [1.480]	36.513 [1.4375]	23	16/32

Flow direction

Shaft rotation	Flow direction	
	Port "A"	Port "B"
Clockwise (CW)	Out	In
Counterclockwise (CCW)	In	Out

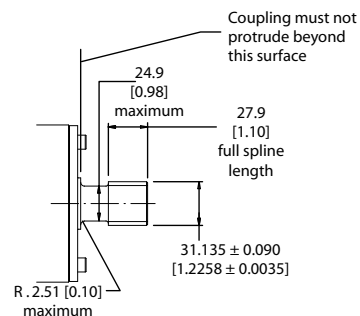
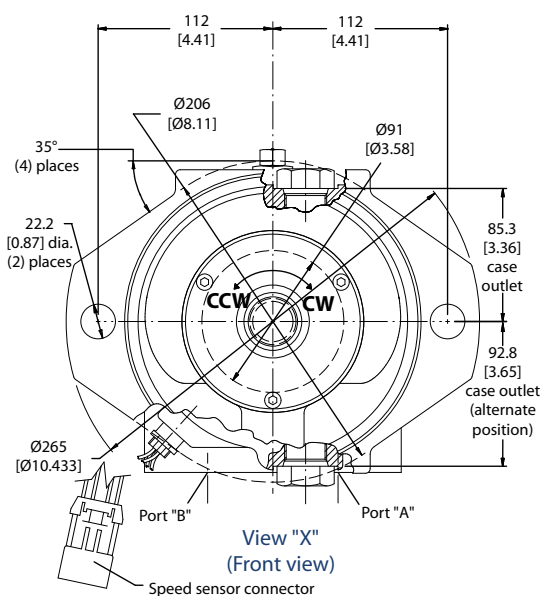

Splined shaft options (see table)

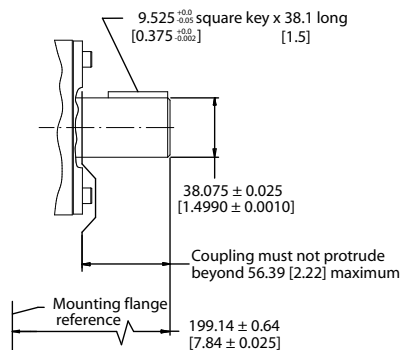

Shaft options K2 (keyed)

P101 447

Installation Drawings

90M75 Fixed Motor SAE Mount

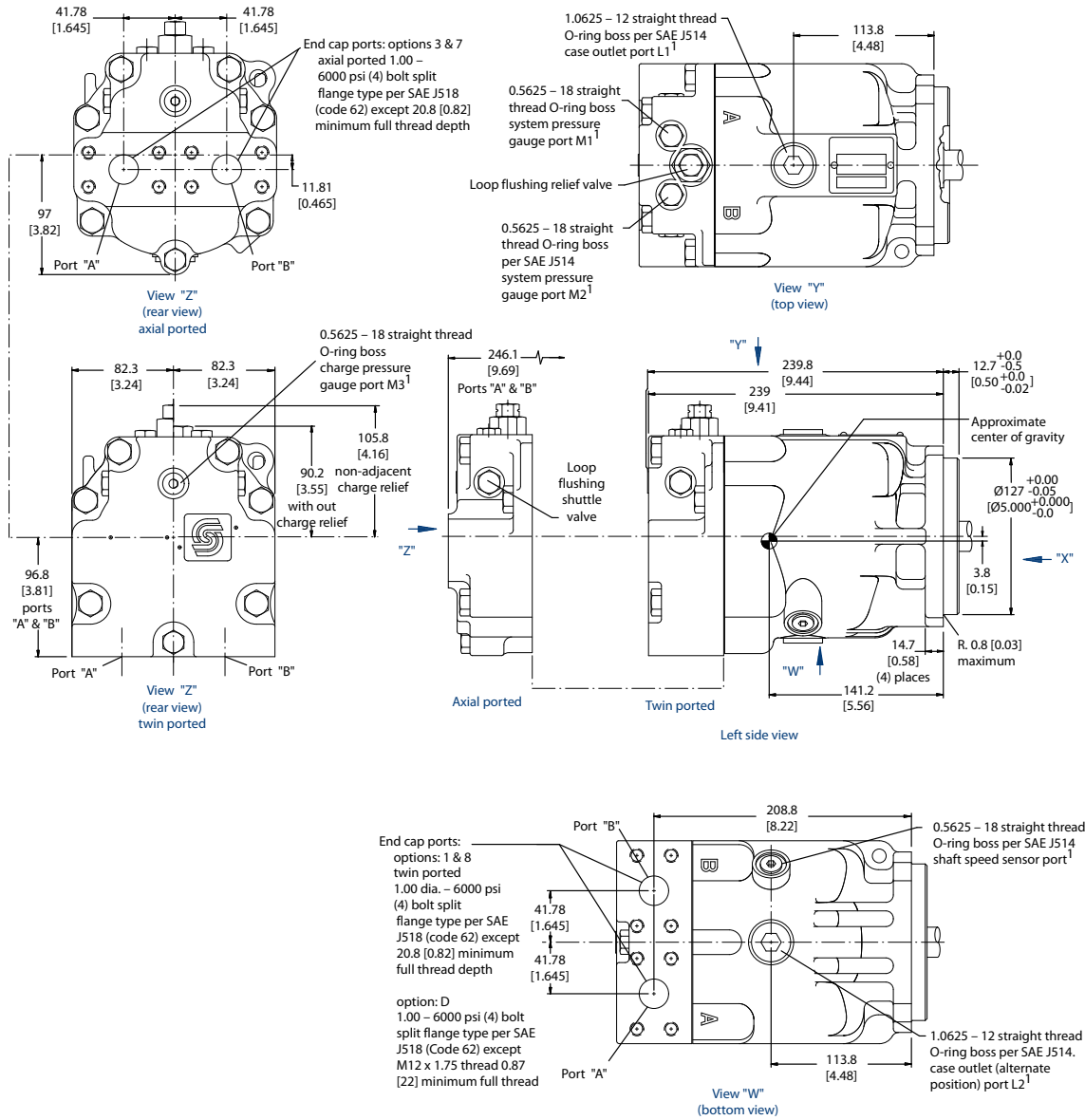

P101 448

All SAE straight thread O-rings ports per SAE J1926 (fittings per SAE 514). Shaft rotation is determined by viewing motor from output shaft end. Contact your Danfoss representative for specific installation drawings

Installation Drawings
Splined output shaft options

Output shaft option	Shaft diameter T	Full spline length U	Major diameter V	Pitch diameter W	Number of Teeth Y	Pitch Z
S1	24.9 [0.96]	27.9 [1.10]	31.13 [1.2256]	29.634 [1.1667]	14	12/24
C6	29 [1.14]	325 [1.26]	24.42 [1.3550]	33.336 [1.3125]	21	16/32
C7	32.3 [1.27]	34.6 [1.37]	37.59 [1.460]	36.513 [1.4375]	23	16/32

Flow direction

Shaft rotation	Flow direction	
	Port "A"	Port "B"
Clockwise (CW)	Out	In
Counterclockwise (CCW)	In	Out

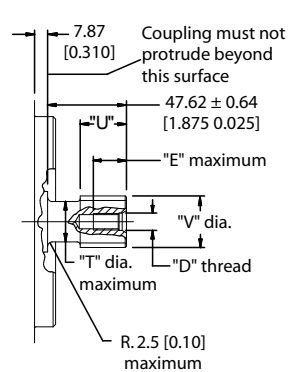
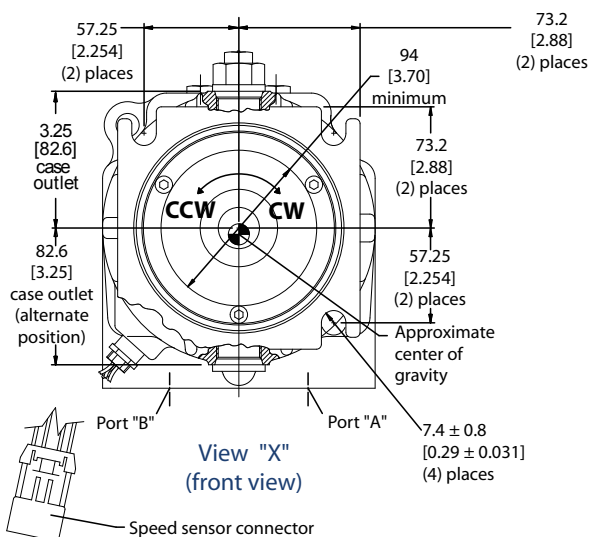
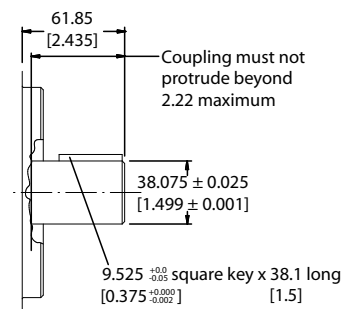
Splined shaft options (see table)

Shaft option K2 (keyed)

P101 449

Installation Drawings

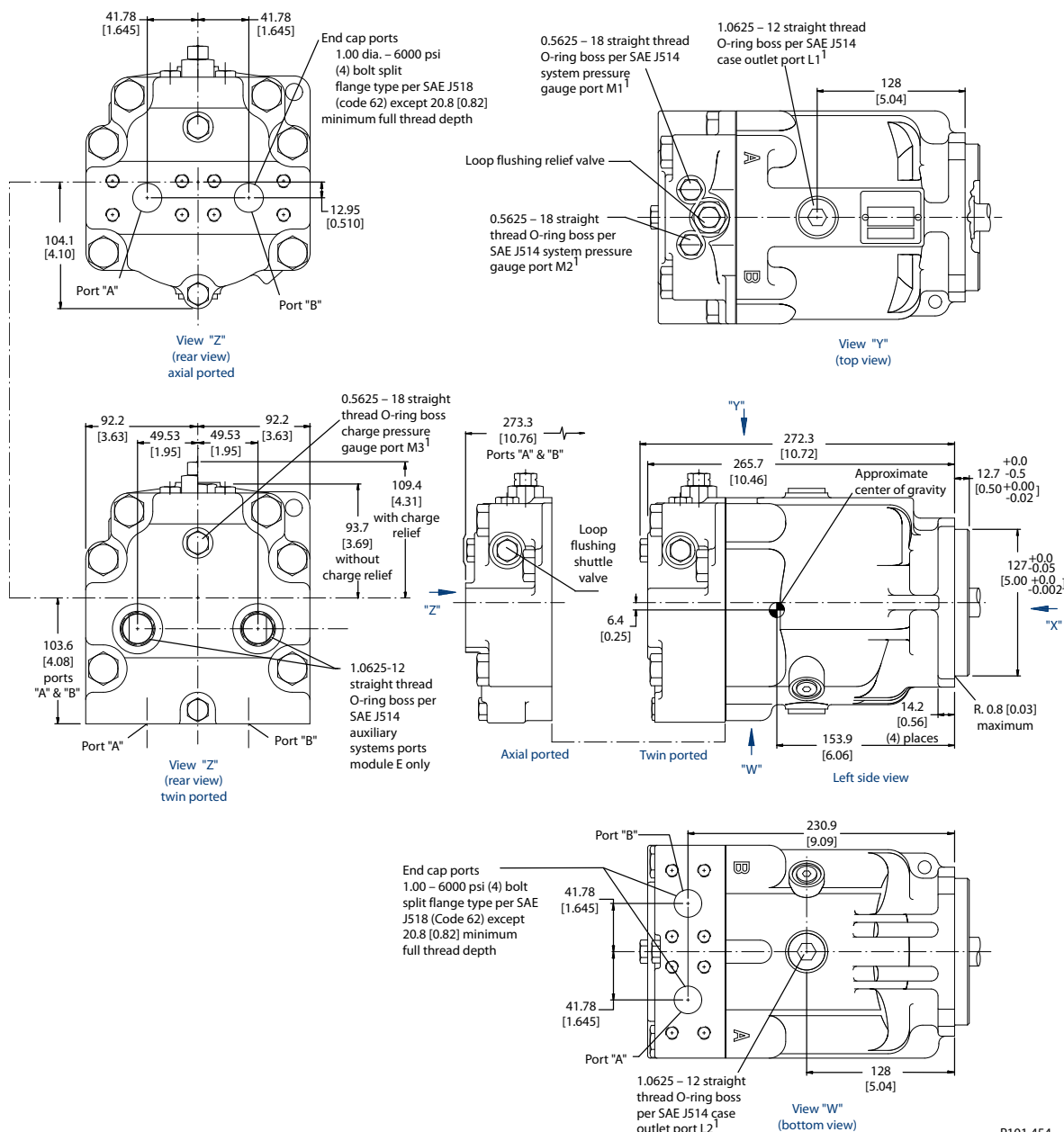
90M100 Fixed Motor SAE Mount



P101 454

All SAE straight thread O-rings ports per SAE J1926 (fittings per SAE 514). Shaft rotation is determined by viewing motor from output shaft end. Contact your Danfoss representative for specific installation drawings

Splined output shaft options

Output shaft option	shaft diameter T	Full spline length U	Major diameter V	Pitch diameter W	Number of teeth Y	Pitch Z	Length S
S1	24.9 [0.98]	27.9 [1.10]	31.13 [1.2258]	29.634 [1.1667]	14	12/24	47.6 [1.875]

Installation Drawings

Splined output shaft options (continued)

Output shaft option	shaft diameter T	Full spline length U	Major diameter V	Pitch diameter W	Number of teeth Y	Pitch Z	Length S
C7	32.3 [1.27]	34.8 [1.37]	37.59 [1.480]	36.513 [1.4375]	23	16/32	47.6 [1.875]
F1	34.5 [1.36]	49.5 [1.95]	43.94 [1.730]	41.275 [1.6250]	13	8/16	66.7 [2.625]
F2	34.5 [1.36]	67.1 [2.64]	43.94 [1.730]	41.275 [1.6250]	13	8/16	84.3 [3.32]

Flow direction

Shaft rotation	Flow direction	
	Port "A"	Port "B"
Clockwise (CW)	Out	In
Counterclockwise (CCW)	In	Out

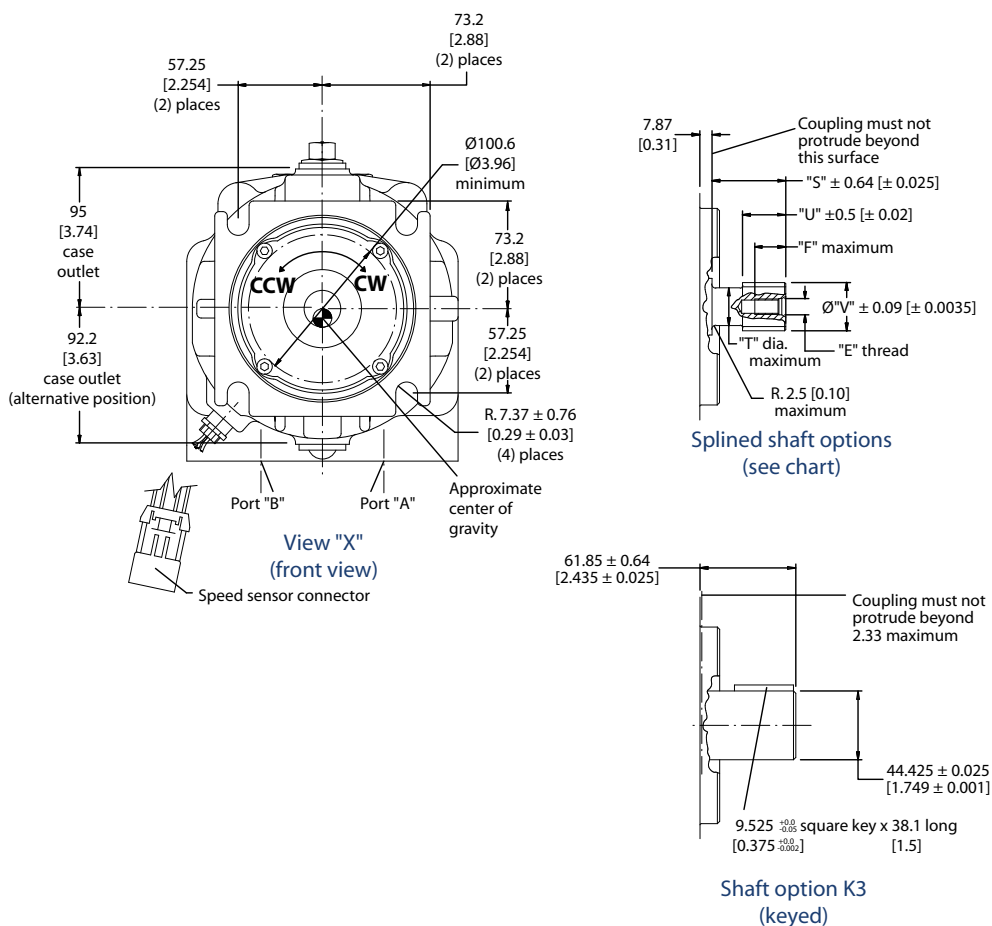

Installation Drawings

90M130 Fixed Motor SAE Mount

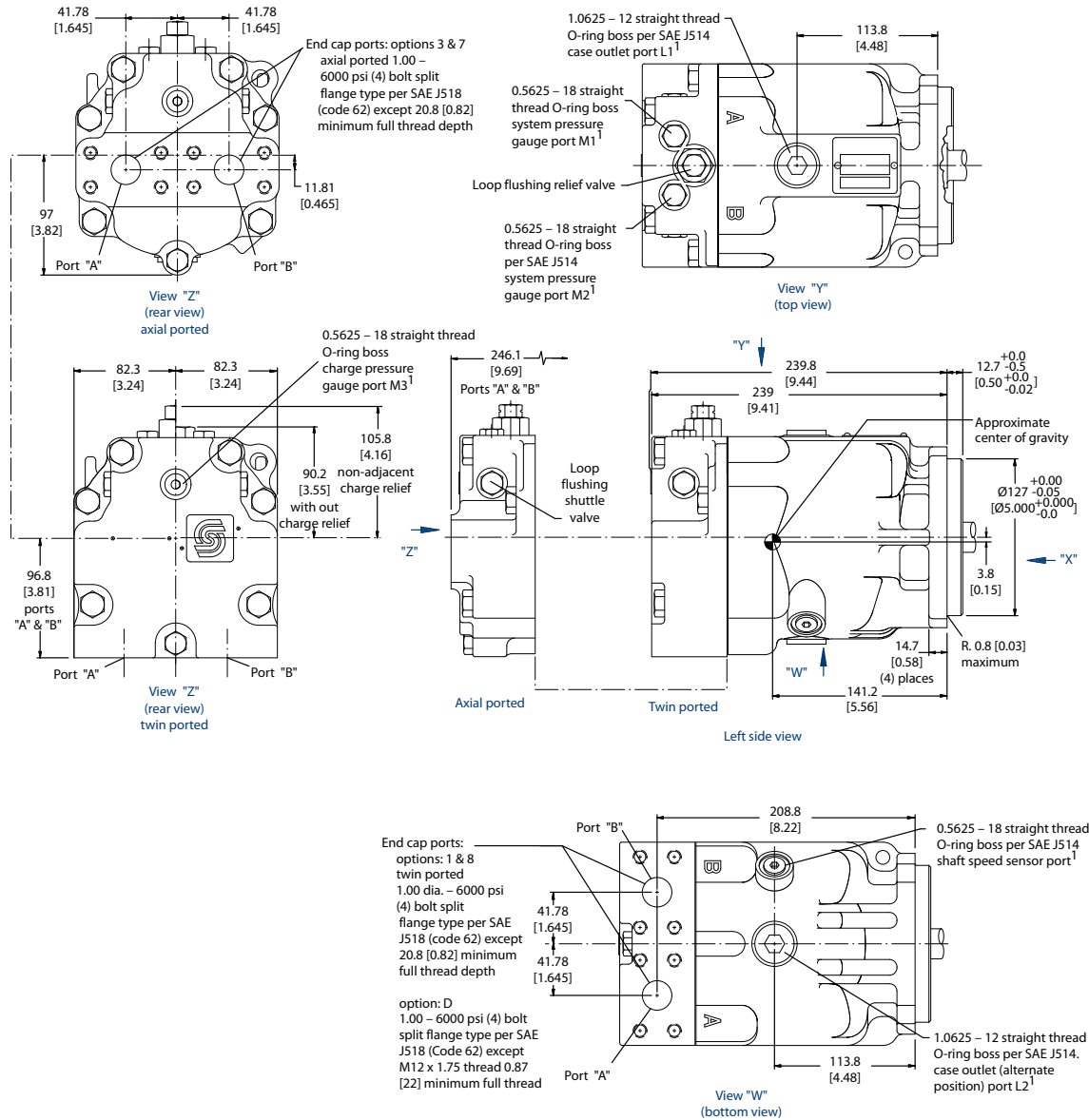

P101 448

All SAE straight thread O-rings ports per SAE J1926 (fittings per SAE 514). Shaft rotation is determined by viewing motor from output shaft end. Contact your Danfoss representative for specific installation drawings

Installation Drawings

Splined output shaft options

Output shaft option	Shaft diameter T	Full spline length U	Major diameter V	Pitch diameter W	Number of teeth Y	Pitch Z	Length S
F1	34.5 [1.36]	42.5 [1.67]	43.94 [1.730]	41.275 [1.6250]	13	8/16	66.7 [2.625]
C8	37.5 [1.48]	42.5 [1.67]	43.94 [1.730]	42.862 [1.6875]	27	16/32	66.7 [2.625]

Flow direction

Shaft rotation	Flow direction	
	Port "A"	Port "B"
Clockwise (CW)	Out	In
Counterclockwise (CCW)	In	Out

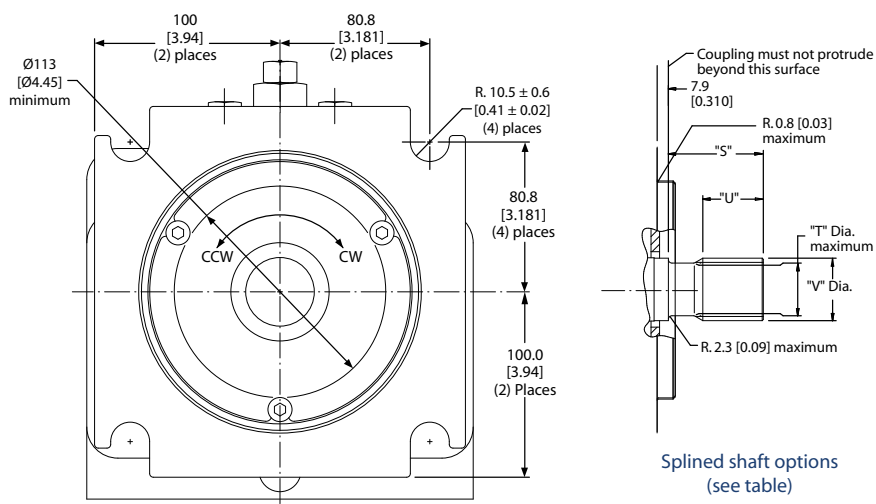

P101 868

All SAE straight thread O-rings ports per SAE J1926 (fittings per SAE 514). Shaft rotation is determined by viewing motor from output shaft end. Contact your Danfoss representative for specific installation drawings.



Products we offer:

- Bent Axis Motors
- Closed Circuit Axial Piston Pumps and Motors
- Displays
- Electrohydraulic Power Steering
- Electrohydraulics
- Hydraulic Power Steering
- Integrated Systems
- Joysticks and Control Handles
- Microcontrollers and Software
- Open Circuit Axial Piston Pumps
- Orbital Motors
- PLUS+1® GUIDE
- Proportional Valves
- Sensors
- Steering
- Transit Mixer Drives

Danfoss Power Solutions is a global manufacturer and supplier of high-quality hydraulic and electronic components. We specialize in providing state-of-the-art technology and solutions that excel in the harsh operating conditions of the mobile off-highway market. Building on our extensive applications expertise, we work closely with our customers to ensure exceptional performance for a broad range of off-highway vehicles.

We help OEMs around the world speed up system development, reduce costs and bring vehicles to market faster.

Danfoss – Your Strongest Partner in Mobile Hydraulics.

Go to www.powersolutions.danfoss.com for further product information.

Wherever off-highway vehicles are at work, so is Danfoss.

We offer expert worldwide support for our customers, ensuring the best possible solutions for outstanding performance. And with an extensive network of Global Service Partners, we also provide comprehensive global service for all of our components.

Please contact the Danfoss Power Solution representative nearest you.

Comatrol

www.comatrol.com

Schwarzmueller-Inverter

www.schwarzmueller-inverter.com

Turolla

www.turollaocg.com

Valmova

www.valmova.com

Hydro-Gear

www.hydro-gear.com

Daikin-Sauer-Danfoss

www.daikin-sauer-danfoss.com

Local address:

Danfoss Power Solutions US Company
2800 East 13th Street
Ames, IA 50010, USA
Phone: +1 515 239 6000

Danfoss Power Solutions GmbH & Co. OHG
Krokamp 35
D-24539 Neumünster, Germany
Phone: +49 4321 871 0

Danfoss Power Solutions ApS
Nordborgvej 81
DK-6430 Nordborg, Denmark
Phone: +45 7488 2222

Danfoss Power Solutions (Shanghai) Co. Ltd.
Building #22, No. 1000 Jin Hai Rd
Jin Qiao, Pudong New District
Shanghai, China 201206
Phone: +86 21 3418 5200

Danfoss can accept no responsibility for possible errors in catalogues, brochures and other printed material. Danfoss reserves the right to alter its products without notice. This also applies to products already on order provided that such alterations can be made without subsequential changes being necessary in specifications already agreed. All trademarks in this material are property of the respective companies. Danfoss and the Danfoss logotype are trademarks of Danfoss A/S. All rights reserved.