

# PGN-plus

Pneumatic · 2-Finger Parallel Gripper · **Universal Gripper**



**Sizes**  
40 .. 380



**Weight**  
0.08 kg .. 39.5 kg

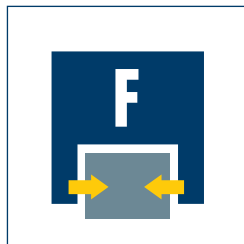

**Gripping force**  
123 N .. 21800 N



**Stroke per finger**  
2.5 mm .. 45 mm



**Workpiece weight**  
0.62 kg .. 80.5 kg

## Application example



Insertion unit for light to medium-weight components

**1** PGN-plus 160 2-Finger Parallel Gripper with workpiece-specific gripper fingers

**2** SRU 63 Rotary Actuator

**3** SLE 50 K Short-stroke Module

**4** SLF 03-P Gantry Axis

### Universal Gripper

Universal 2-finger parallel gripper with large gripping force and high maximum moments thanks to multiple-tooth guide

#### Area of application

Ideal standard solution for numerous areas of application. For universal use in clean to slightly dirty environments, special versions available for dirty environments.

#### Your advantages and benefits

##### Robust multiple-tooth guidance

for precise handling

##### High maximum load capabilities possible

suitable for the use of long gripper fingers

##### Oval piston drive design

for maximum gripping forces

##### Mounting from two sides in three screw directions

for universal and flexible gripper assembly

##### Air supply via hose-free direct connection or screw connections

for the flexible supply of compressed air in all automation systems

##### Comprehensive sensor accessories

for diverse monitoring tasks and stroke position monitoring

##### Compact dimensions

for minimal interfering contours in handling

##### Diverse options

(dust protection, high temperature, anti-corrosion and many more) for optimization to suit precisely your requirements



### General information on the series

#### Working principle

Wedge-hook kinematics

#### Housing material

Aluminum alloy, hard-anodized

#### Base jaw material

Steel

#### Actuation

Pneumatic, with filtered compressed air (10 µm): Dry, lubricated or non-lubricated  
Pressure medium: Requirements on quality of the compressed air according to DIN ISO 8573-1: 6 4 4.

#### Warranty

24 months

#### Scope of delivery

Brackets for proximity switches, guide centering sleeves, O-rings for direct connection, Assembly and Operating Manual with manufacturer's declaration

#### Gripping force safety device

with either mechanical gripping force safety device or SDV-P pressure maintenance valve

### Sectional diagram

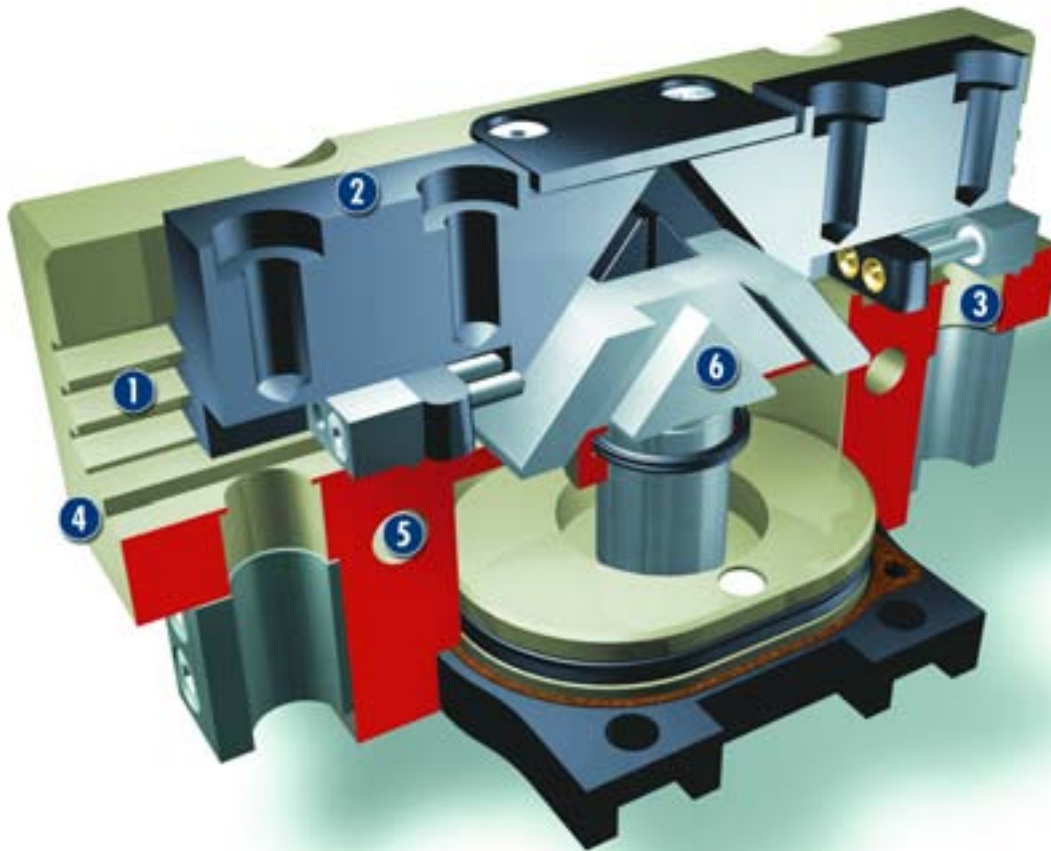

- 1 Multiple-tooth guidance**  
high load-bearing base jaw guide with minimum play for long fingers
- 2 Base jaws**  
for the connection of workpiece-specific gripper fingers
- 3 Sensor system**  
brackets for proximity switches and adjustable operating switch cams in the housing
- 4 Housing**  
weight-reduced through the use of a hard-anodized, high-strength aluminum alloy
- 5 Centering and mounting possibilities**  
for universal gripper assembly
- 6 Kinematics**  
wedge-hook principle for high power transmission and synchronous gripping

### Function description

The oval piston is moved up or down by means of compressed air. Through its angular active surfaces, the wedge hook transforms this motion into the lateral, synchronous gripping movement of both base jaws.

### Options and special information

#### Version with dust cover

Absolutely sealed, increased degree of protection against the ingress of materials, for use in dusty environments

#### Anti-corrosion version

For use in corrosion-inducing atmospheres

#### High-temperature version

For use in hot environments

#### Version with increased grip force

When higher gripping forces are required

### Accessories

Accessories from SCHUNK – the suitable supplement for maximum functionality, reliability and performance of all automation modules.

Centering sleeves

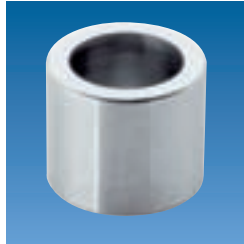

Fittings



MMS magnetic switches



IN inductive proximity switches

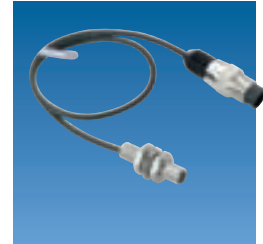

HUE protective cover



KV/KA sensor cables



BSWS quick-change jaw system



V sensor distributors



SDV-P pressure maintenance valves



Finger blanks



FMS force measuring system



APS analog position sensor



FPS flexible position sensor

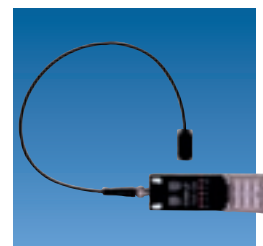

① For the exact size of the required accessories, availability of this size and the designation and ID, please refer to the additional views at the end of the size in question. You will find more detailed information on our accessory range in the „Accessories“ catalog section.

### General information on the series

#### Gripping force

is the arithmetic total of the gripping force applied to each jaw at distance P (see illustration), measured from the upper edge of the gripper.

#### Finger length

is measured from the upper edge of the gripper housing in the direction of the main axis.

#### Repeat accuracy

is defined as the spread of the limit position after 100 consecutive strokes.

#### Workpiece weight

The recommended workpiece weight is calculated for a force-type connection with a coefficient of friction of 0.1 and a safety factor of 2 against slippage of the workpiece on acceleration due to gravity g. Considerably heavier workpiece weights are permitted with form-fit gripping.

#### Closing and opening times

Closing and opening times are purely the times that the base jaws or fingers are in motion. Valve switching times, hose filling times or PLC reaction times are not included in the above times and must be taken into consideration when determining cycle times.

# PGN-plus 40

Pneumatic · 2-Finger Parallel Gripper · **Universal Gripper**



## Gripping force, I.D. gripping

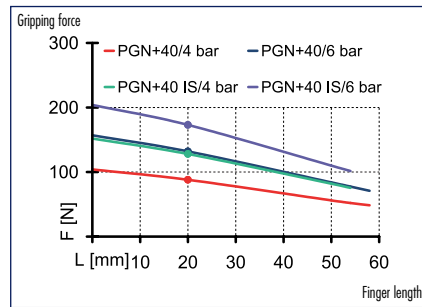

## Gripping force, O.D. gripping

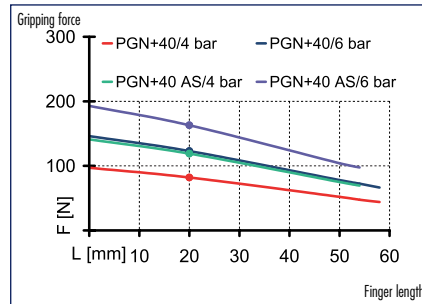

## Finger load

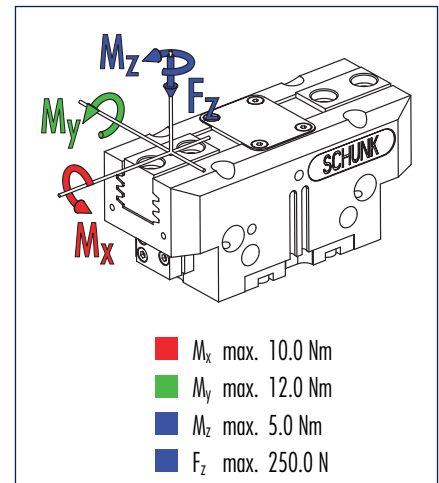

① Moments and forces apply per base jaw and may occur simultaneously.  $M_y$  may arise in addition to the moment generated by the gripping force itself. If the max. permitted finger weight is exceeded, it is imperative to throttle the air pressure so that the jaw movement occurs without any hitting or bouncing. Service life may reduce.

## Technical data

Description		PGN-plus 40	PGN-plus 40-AS	PGN-plus 40-IS
	ID	0371080	0371082	0371084
Stroke per jaw	[mm]	2.5	2.5	2.5
Closing force	[N]	123.0	163.0	
Opening force	[N]	132.0		182.0
Min. spring force	[N]		40.0	50.0
Weight	[kg]	0.08	0.1	0.1
Recommended workpiece weight	[kg]	0.62	0.62	0.62
Air consumption per double stroke	[cm <sup>3</sup> ]	2.5	5.5	5.5
Minimum pressure	[bar]	2.5	4.0	4.0
Maximum pressure	[bar]	8.0	6.5	6.5
Nominal pressure	[bar]	6.0	6.0	6.0
Closing time	[s]	0.02	0.02	0.03
Opening time	[s]	0.02	0.03	0.02
Max. permitted finger length	[mm]	58.0	54.0	54.0
Max. permitted weight per finger	[kg]	0.1	0.1	0.1
IP rating		40	40	40
Min. ambient temperature	[°C]	-10.0	-10.0	-10.0
Température ambiante max.	[°C]	90.0	90.0	90.0
Repeat accuracy	[mm]	0.01	0.01	0.01

### OPTIONS and their characteristics

Dust-protection version	ID	37371080	37371082	37371084
IP rating		64	64	64
Weight	[kg]	0.1	0.12	0.12
Anti-corrosion version	ID	38371080	38371082	38371084
High-temperature version	ID	39371080	39371082	39371084
Min. ambient temperature	[°C]	-10.0	-10.0	-10.0
Température ambiante max.	[°C]	130.0	130.0	130.0

### Main views

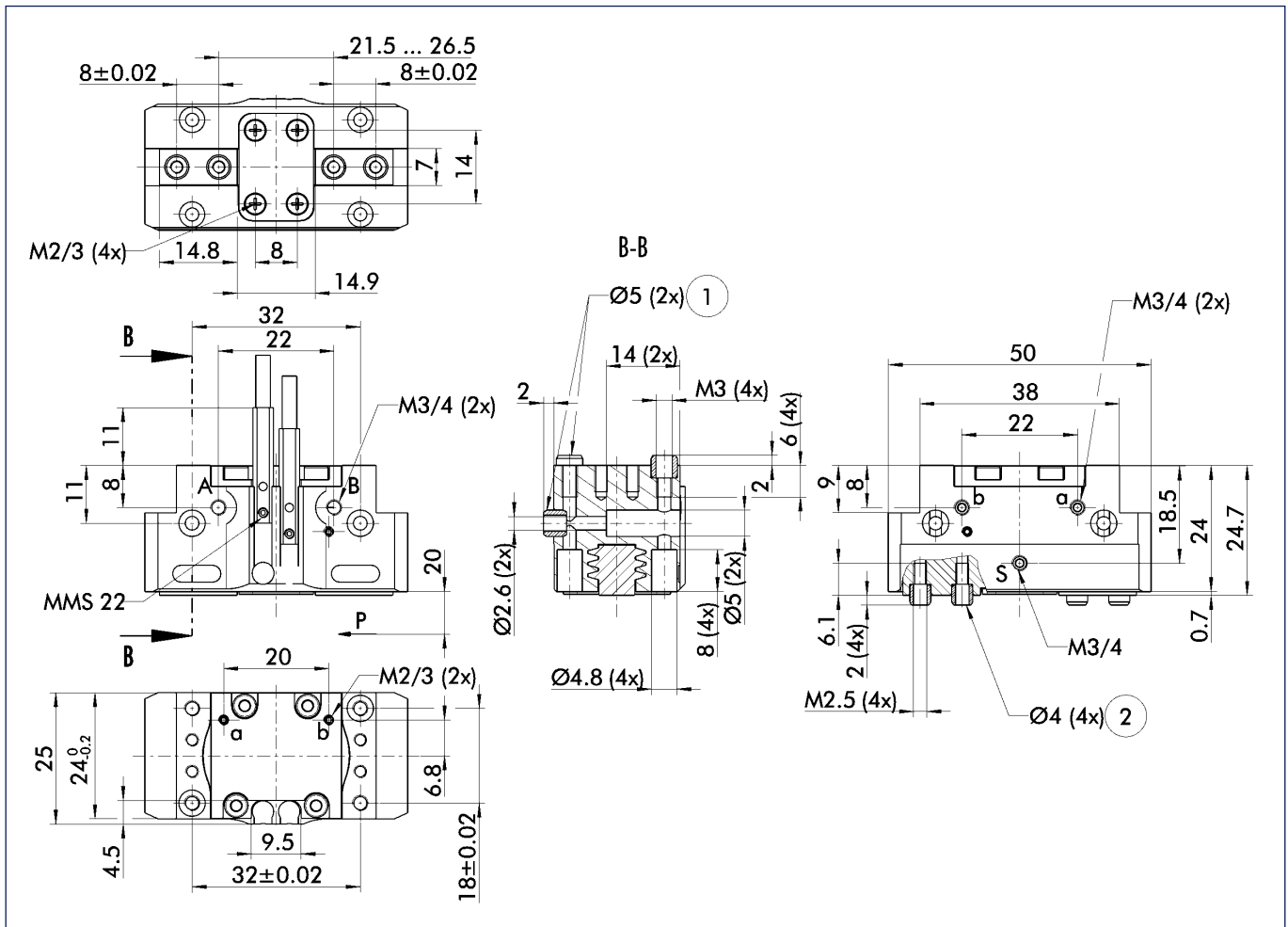

The drawing shows the gripper in the basic version with closed jaws, the dimensions do not include the options described below.

① The SDV-P pressure maintenance valve can also be used (see „Accessories“ catalog section) for I.D. or O.D. gripping as an alternative or in addition to the spring-loaded, mechanical gripping force safety device.

- A,a Main/direct connection, gripper opening
- B,b Main/direct connection, gripper closing
- S,s Air purge or ventilation hole
- ① Gripper connection
- ② Finger connection

### Hose-free direct connection

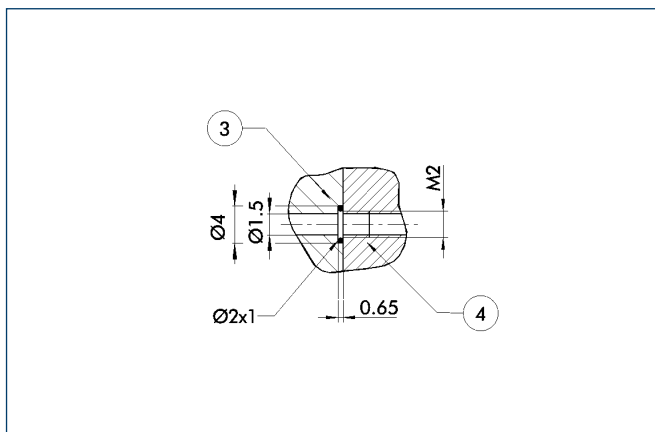

③ Adapter

④ Gripper

The direct connection is used for supplying compressed air to the gripper without hoses. Instead, the pressure medium is fed through bore-holes in the mounting plate.

### AS/IS gripping force safety device

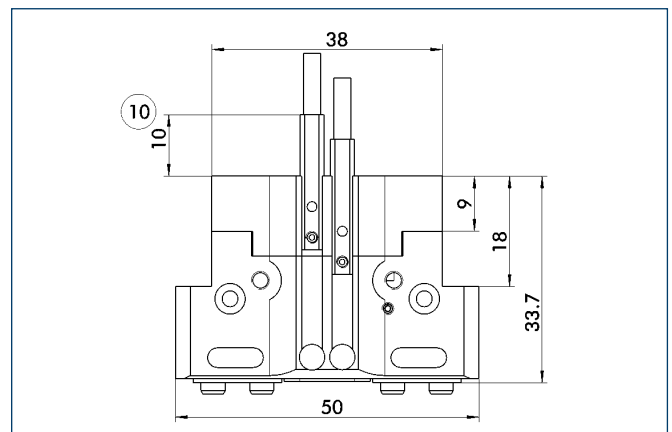

⑩ Projection only with AS version

The mechanical gripping force safety device ensures a minimum gripping force even if there is a drop in pressure. This acts as closing force in the AS version, and as opening force in the IS version. In addition, the gripping force safety device can also be employed as a gripping force booster or for single-acting gripping.



# PGN-plus 40

Pneumatic · 2-Finger Parallel Gripper · **Universal Gripper**

## Version with dust cov

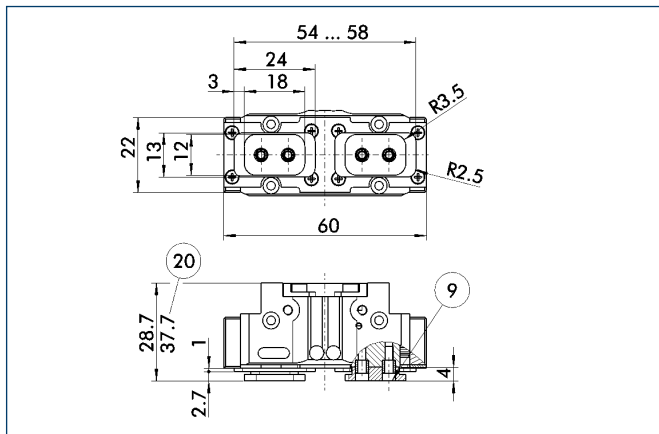

- ⑨ For screw connection diagram, see basic version
- ⑳ With AS / IS version

The „dust-protection“ option increases the degree of protection against penetrating substances. The screw connection diagram shifts by the height of the intermediate jaw. The finger length is still measured from the upper edge of the gripper housing.

## Finger blanks

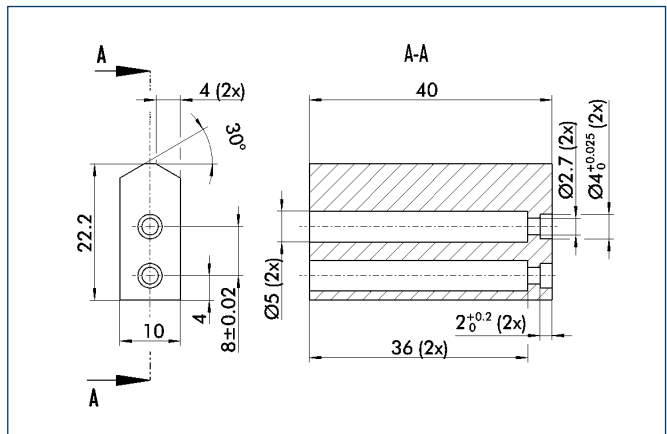

Finger blanks for customized subsequent machining, incl. screw connection diagram

Designation	Material	Scope of delivery	ID
ABR-plus 40	Aluminum	1	0300008
SBR-plus 40	16 MnCr 5	1	0300018

## HUE protective cover

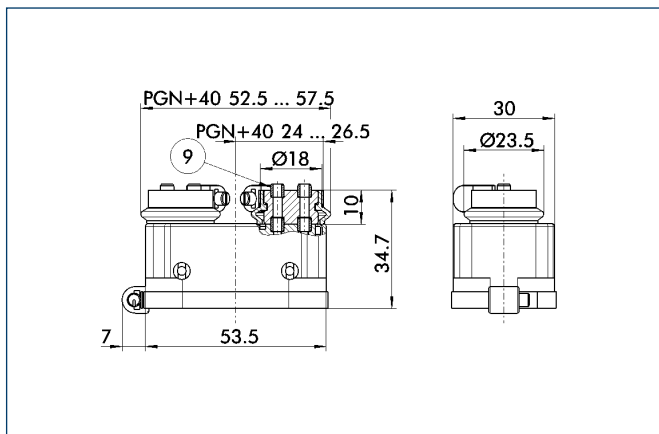

- ⑨ For screw connection diagram, see basic version

The HUE protective cover completely protects the gripper against external influences up to IP65 if an additional sealing of the cover bottom is provided as part of the application. The mounting diagram shifts by the height of the intermediate jaw.

Description	ID	ISO-Classification 14644-1
HUE PGN-plus 40	0371490	2



You can find more detailed information and individual parts of the above-mentioned accessories in the „Accessories“ catalog section.

### Sensor system

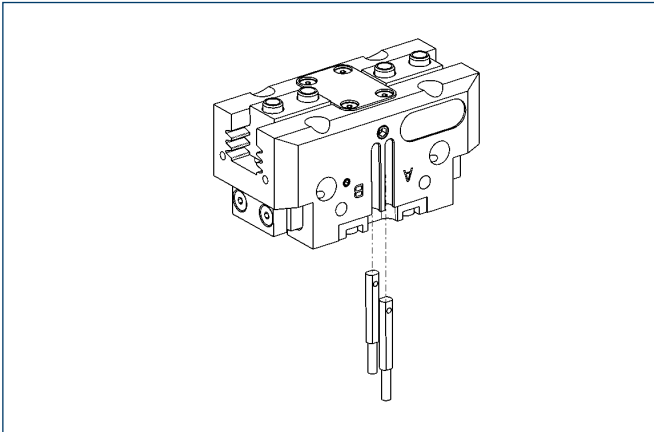

#### End position monitoring:

#### Electronic magnetic switches, for mounting in C-slot

Description	ID	Recommended product
MMS 22-S-M5-NPN	0301439	
MMS 22-S-M5-NPN-SA	0301449	
MMS 22-S-M5-PNP	0301438	
MMS 22-S-M5-PNP-SA	0301448	
MMS 22-S-M8-NPN	0301433	
MMS 22-S-M8-NPN-SA	0301443	
MMS 22-S-M8-PNP	0301432	•
MMS 22-S-M8-PNP-SA	0301442	
MMSK 22-S-NPN	0301435	
MMSK 22-S-NPN-SA	0301445	
MMSK 22-S-PNP	0301434	
MMSK 22-S-PNP-SA	0301444	

① Two sensors (NO contacts) are required for each gripper, plus extension cables as an option.

#### Extension cables for proximity switches/magnetic switches

Description	ID
KA BG05-L 3P-0300	0301652
KA BG08-L 3P-0300-PNP	0301622
KA BW05-L 3P-0300	0301650
KA BW08-L 3P-0300-NPN	0301602
KA BW08-L 3P-0300-PNP	0301594
KA BW08-L 3P-0500-NPN	9641116
KA BW08-L 3P-0500-PNP	0301502
KV BW08-SG08 3P-0030-PNP	0301495
KV BW08-SG08 3P-0100-PNP	0301496
KV BW08-SG08 3P-0200-PNP	0301497

① Please note the minimum permitted bending radii for the sensor cables, which are generally 35 mm.



You can find more detailed information and individual parts of the above-mentioned accessories in the „Accessories“ catalog section.



### Maximum permitted finger offset

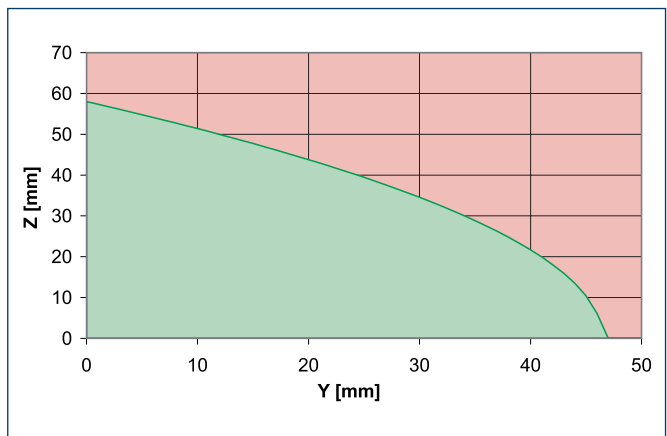
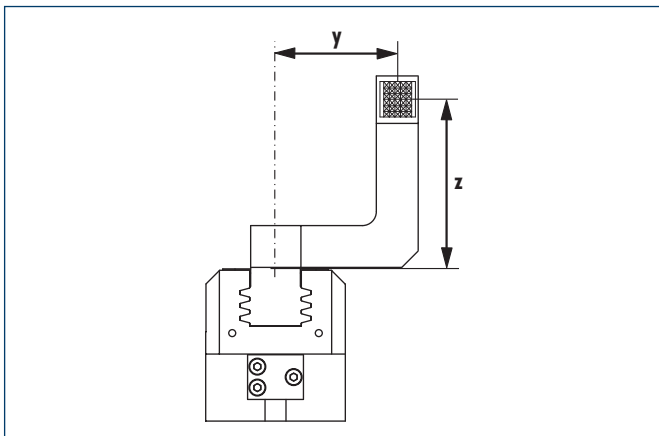

- Permitted range
- Non-permissible range

The curve applies to the basic version (stroke -1). For other versions, the curve will be parallel but offset in line with the max. permitted finger length.



You can find more detailed information and individual parts of the above-mentioned accessories in the „Accessories“ catalog section.

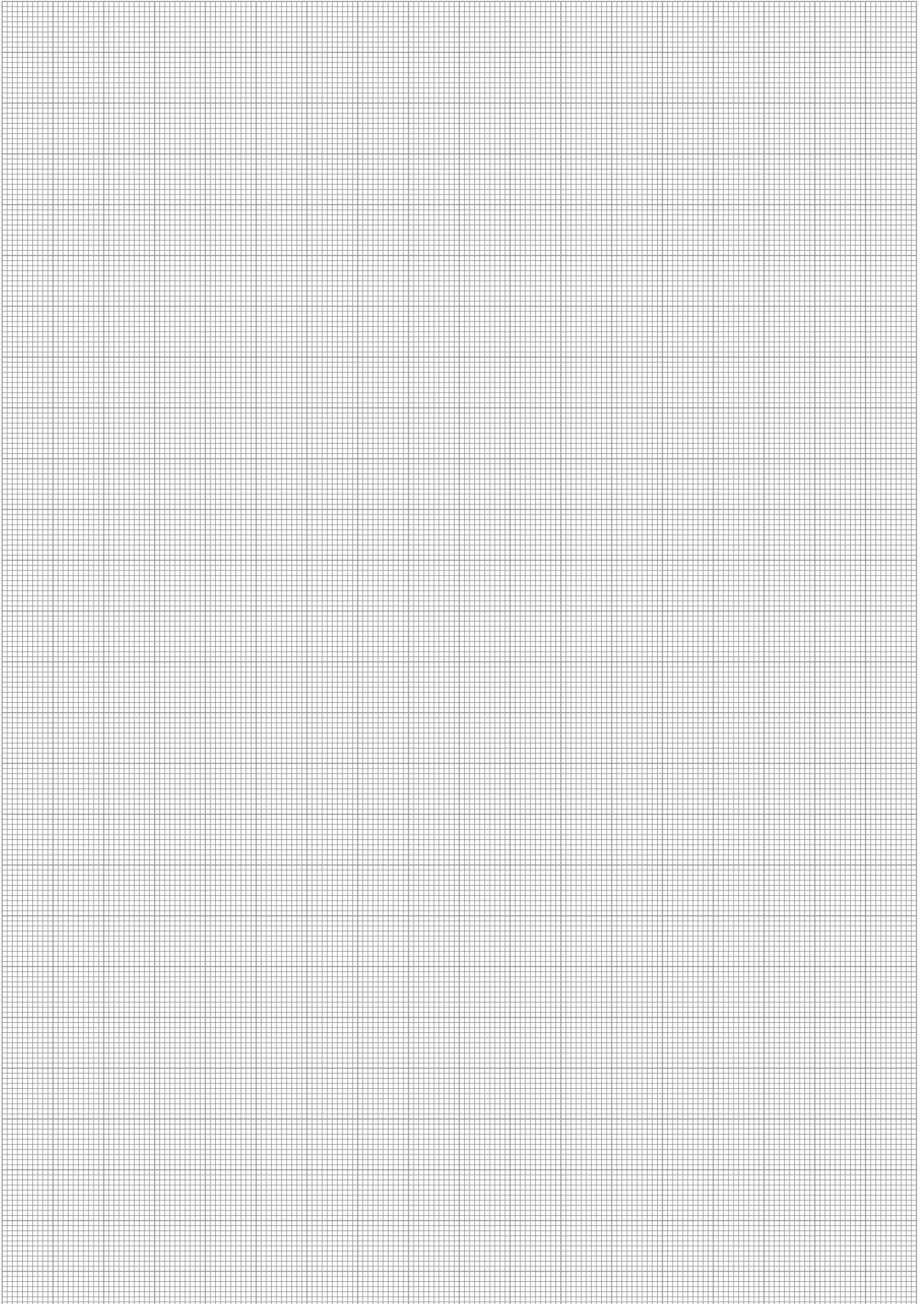

# PGN-plus 50

Pneumatic · 2-Finger Parallel Gripper · Universal Gripper



## Gripping force, I.D. gripping

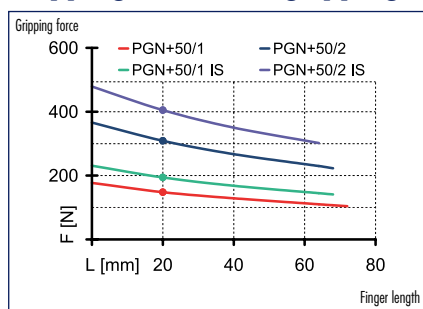

## Gripping force, O.D. gripping

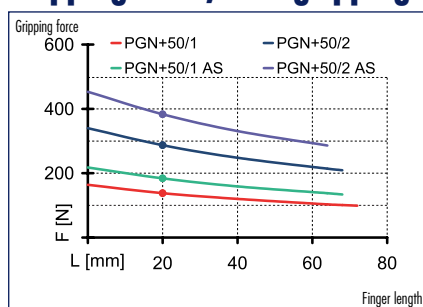

## Finger load

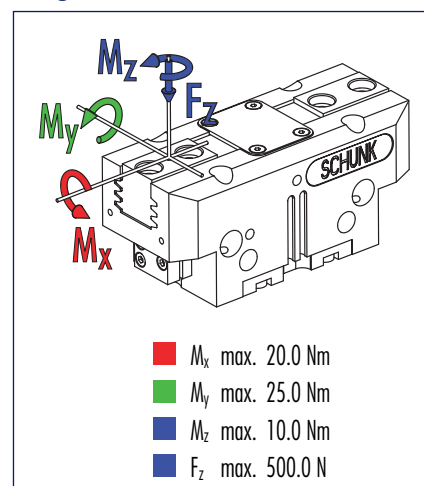

① Moments and forces apply per base jaw and may occur simultaneously.  $M_y$  may arise in addition to the moment generated by the gripping force itself. If the max. permitted finger weight is exceeded, it is imperative to throttle the air pressure so that the jaw movement occurs without any hitting or bouncing. Service life may reduce.

## Technical data

Description		PGN-plus 50-1	PGN-plus 50-2	PGN-plus 50-1-AS	PGN-plus 50-2-AS	PGN-plus 50-1-IS	PGN-plus 50-2-IS
	ID	0371099	0371149	0371399	0371449	0371459	0371469
Stroke per jaw	[mm]	4.0	2.0	4.0	2.0	4.0	2.0
Closing force	[N]	140.0	290.0	185.0	385.0		
Opening force	[N]	145.0	310.0			190.0	405.0
Min. spring force	[N]			45.0	95.0	45.0	95.0
Weight	[kg]	0.17	0.17	0.21	0.21	0.21	0.21
Recommended workpiece weight	[kg]	0.7	1.45	0.7	1.45	0.7	1.45
Air consumption per double stroke	[cm <sup>3</sup> ]	5.0	5.0	5.0	5.0	5.0	5.0
Minimum pressure	[bar]	2.5	2.5	4.0	4.0	4.0	4.0
Maximum pressure	[bar]	8.0	8.0	6.5	6.5	6.5	6.5
Nominal pressure	[bar]	6.0	6.0	6.0	6.0	6.0	6.0
Closing time	[s]	0.02	0.02	0.02	0.02	0.03	0.03
Opening time	[s]	0.02	0.02	0.03	0.03	0.02	0.02
Max. permitted finger length	[mm]	72.0	68.0	68.0	68.0	64.0	64.0
Max. permitted weight per finger	[kg]	0.18	0.18	0.18	0.18	0.18	0.18
IP rating		40	40	40	40	40	40
Min. ambient temperature	[°C]	-10.0	-10.0	-10.0	-10.0	-10.0	-10.0
Température ambiante max.	[°C]	90.0	90.0	90.0	90.0	90.0	90.0
Repeat accuracy	[mm]	0.01	0.01	0.01	0.01	0.01	0.01

### OPTIONS and their characteristics

Description	ID	37371099	37371149	37371399	37371449	37371459	37371469
Dust-protection version							
IP rating		64	64	64	64	64	64
Weight	[kg]	0.2	0.2	0.24	0.24	0.24	0.24
Anti-corrosion version	ID	38371099	38371149	38371399	38371449	38371459	38371469
High-temperature version	ID	39371099	39371149	39371399	39371449	39371459	39371469
Min. ambient temperature	[°C]	-10.0	-10.0	-10.0	-10.0	-10.0	-10.0
Température ambiante max.	[°C]	130.0	130.0	130.0	130.0	130.0	130.0
KVZ for increased grip force	ID	0372099	0372149	0372399		0372459	
Description		PGN-plus 50-1-KVZ	PGN-plus 50-2-KVZ	PGN-plus 50-1-AS-KVZ		PGN-plus 50-1-IS-KVZ	
Closing force	[N]	250.0	520.0	295.0			
Opening force	[N]	260.0	560.0			305.0	
Weight	[kg]	0.21	0.21	0.26		0.26	
Maximum pressure	[bar]	6.0	6.0	6.0		6.0	
Max. permitted finger length	[mm]	64.0	50.0	50.0		50.0	

### Main views

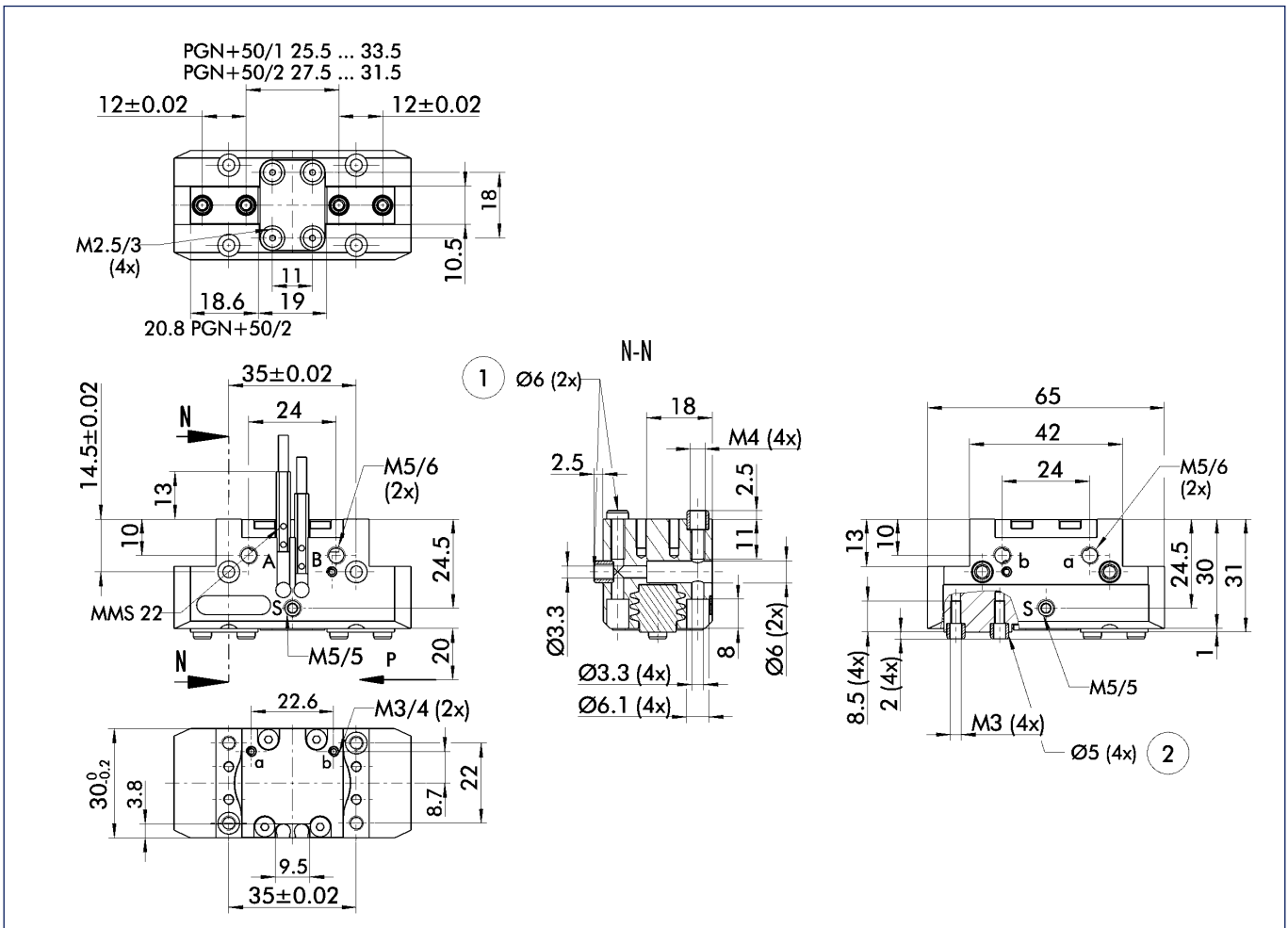

The drawing shows the gripper in the basic version with closed jaws, the dimensions do not include the options described below.

① The SDV-P pressure maintenance valve can also be used (see „Accessories“ catalog section) for I.D. or O.D. gripping as an alternative or in addition to the spring-loaded, mechanical gripping force safety device.

- A,a Main/direct connection, gripper opening
- B,b Main/direct connection, gripper closing
- S,s Air purge or ventilation hole
- ① Gripper connection
- ② Finger connection

### Hose-free direct connection

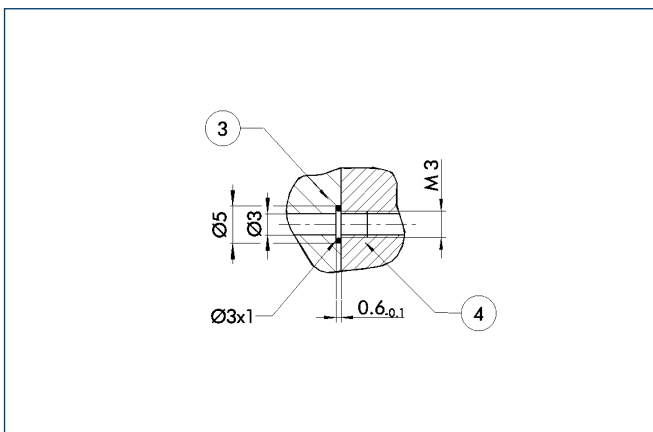

③ Adapter

④ Gripper

The direct connection is used for supplying compressed air to the gripper without hoses. Instead, the pressure medium is fed through bore-holes in the mounting plate.

### AS/IS gripping force safety device

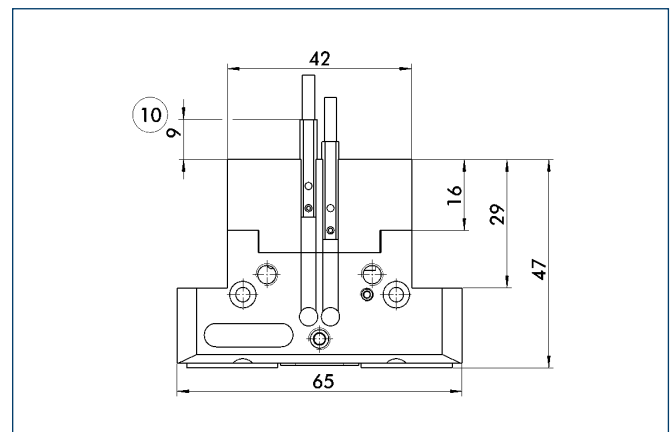

⑩ Projection only with AS version

The mechanical gripping force safety device ensures a minimum gripping force even if there is a drop in pressure. This acts as closing force in the AS version, and as opening force in the IS version. In addition, the gripping force safety device can also be employed as a gripping force booster or for single-acting gripping.

# PGN-plus 50

Pneumatic · 2-Finger Parallel Gripper · Universal Gripper

## Version with dust cover

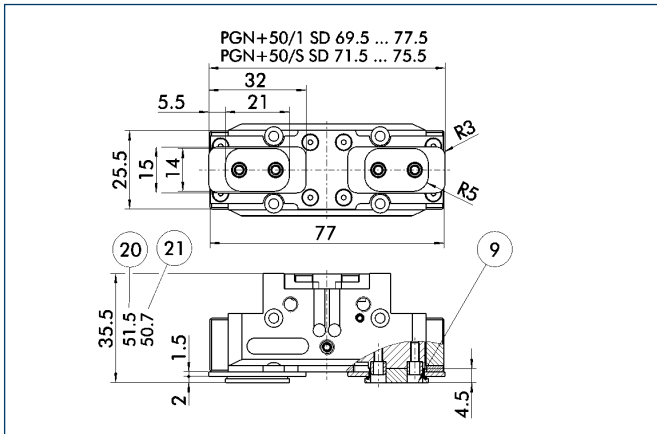

- ⑨ For screw connection diagram, see basic version
- ⑳ With AS / IS version
- ㉑ For KVZ version

The „dust-protection“ option increases the degree of protection against penetrating substances. The screw connection diagram shifts by the height of the intermediate jaw. The finger length is still measured from the upper edge of the gripper housing.

## KVZ for increased grip force

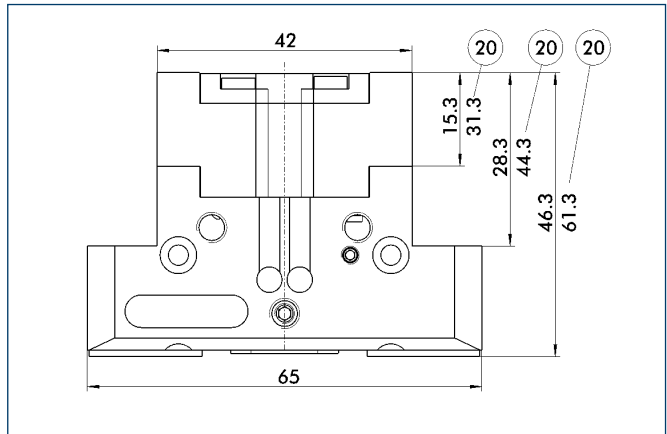

- ㉒ With AS / IS version

The KVZ cylinder increases the gripping forces during opening and closing. A second, in series-connected piston also increases the force on the wedge hook. The full gripping force shown in the data table is sometimes only reached after a few hundred gripping cycles. Please consider that grippers which are equipped with a gripping force safety device (AS / IS) are higher

## HUE protective cover

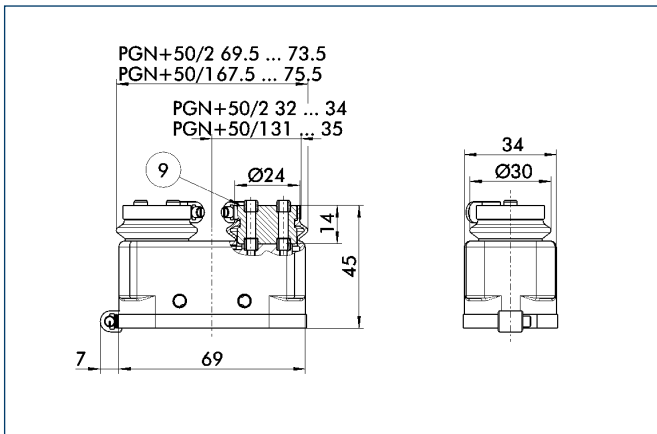

- ⑨ For screw connection diagram, see basic version

The HUE protective cover completely protects the gripper against external influences up to IP65 if an additional sealing of the cover bottom is provided as part of the application. The mounting diagram shifts by the height of the intermediate jaw.

Description	ID
HUE PGN-plus 50	0371479

## Finger blanks

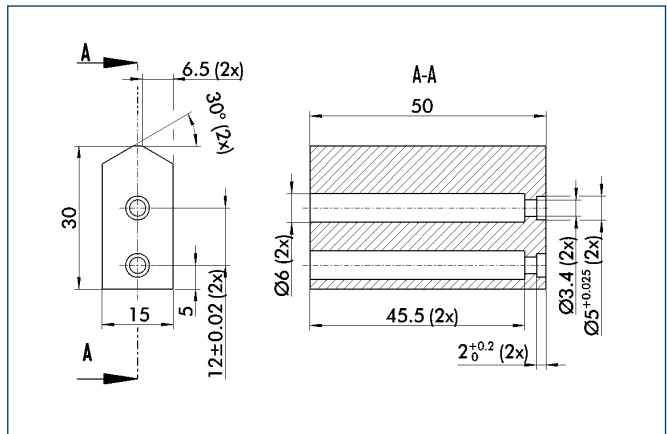

Finger blanks for customized subsequent machining, incl. screw connection diagram

Description	Material	Scope of delivery	ID
ABR-plus 50	Aluminum	1	0300009
SBR-plus 50	16 MnCr 5	1	0300019



You can find more detailed information and individual parts of the above-mentioned accessories in the „Accessories“ catalog section.



### Sensor system

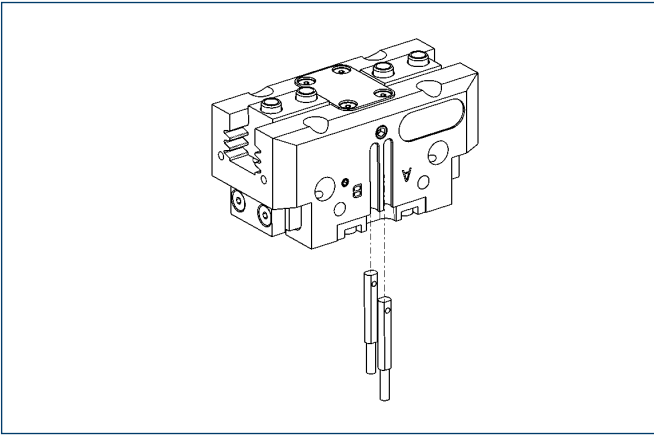

#### End position monitoring:

#### Electronic magnetic switches, for mounting in C-slot

Description	ID	Recommended product
MMS 22-S-M5-NPN	0301439	
MMS 22-S-M5-NPN-SA	0301449	
MMS 22-S-M5-PNP	0301438	
MMS 22-S-M5-PNP-SA	0301448	
MMS 22-S-M8-NPN	0301433	
MMS 22-S-M8-NPN-SA	0301443	
MMS 22-S-M8-PNP	0301432	•
MMS 22-S-M8-PNP-SA	0301442	
MMSK 22-S-NPN	0301435	
MMSK 22-S-NPN-SA	0301445	
MMSK 22-S-PNP	0301434	
MMSK 22-S-PNP-SA	0301444	

① Two sensors (NO contacts) are required for each gripper, plus extension cables as an option.

#### Extension cables for proximity switches/magnetic switches

Description	ID
KA BG05-L 3P-0300	0301652
KA BG08-L 3P-0300-PNP	0301622
KA BW05-L 3P-0300	0301650
KA BW08-L 3P-0300-NPN	0301602
KA BW08-L 3P-0300-PNP	0301594
KA BW08-L 3P-0500-NPN	9641116
KA BW08-L 3P-0500-PNP	0301502
KV BW08-SG08 3P-0030-PNP	0301495
KV BW08-SG08 3P-0100-PNP	0301496
KV BW08-SG08 3P-0200-PNP	0301497

① Please note the minimum permitted bending radii for the sensor cables, which are generally 35 mm.



You can find more detailed information and individual parts of the above-mentioned accessories in the „Accessories“ catalog section.



### Maximum permitted finger offset

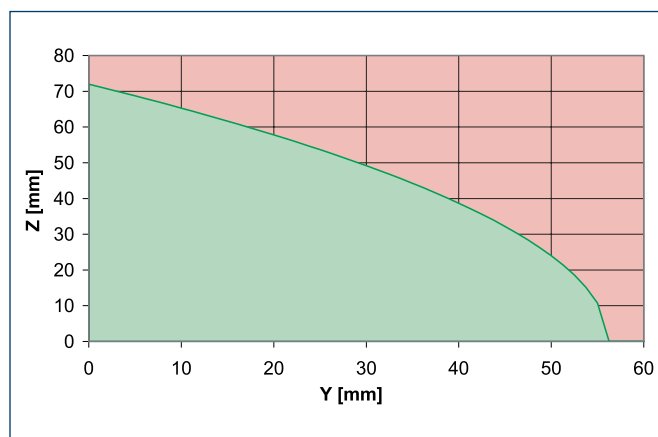
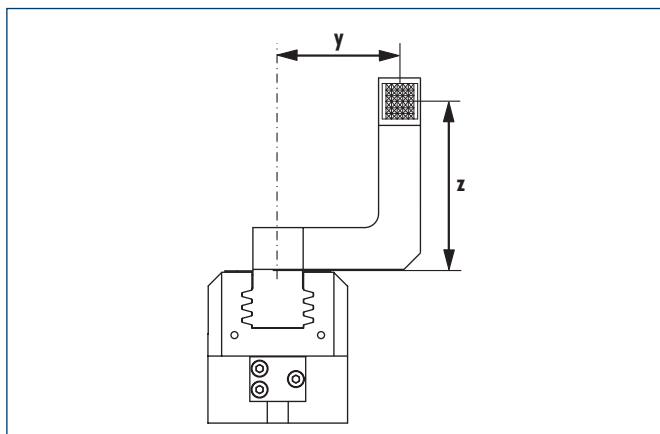

- Permitted range
- Non-permissible range

The curve applies to the basic version (stroke -1). For other versions, the curve will be parallel but offset in line with the max. permitted finger length.



You can find more detailed information and individual parts of the above-mentioned accessories in the „Accessories“ catalog section.

# PGN-plus 64

Pneumatic · 2-Finger Parallel Gripper · Universal Gripper



## Gripping force, I.D. gripping

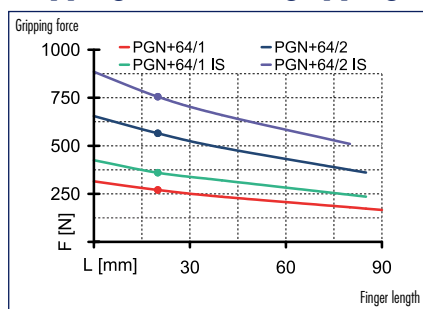

## Gripping force, O.D. gripping

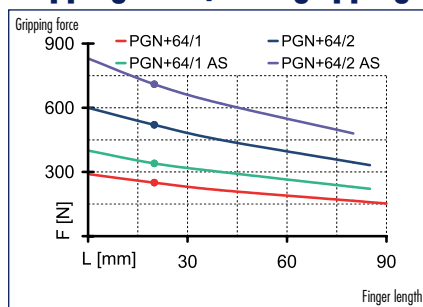

## Finger load

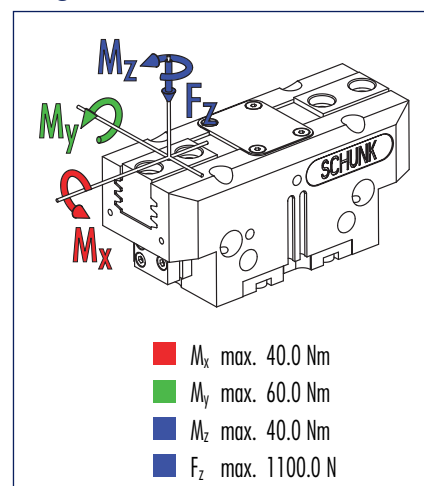

① Moments and forces apply per base jaw and may occur simultaneously.  $M_y$  may arise in addition to the moment generated by the gripping force itself. If the max. permitted finger weight is exceeded, it is imperative to throttle the air pressure so that the jaw movement occurs without any hitting or bouncing. Service life may reduce.

## Technical data

Description		PGN-plus 64-1	PGN-plus 64-2	PGN-plus 64-1-AS	PGN-plus 64-2-AS	PGN-plus 64-1-IS	PGN-plus 64-2-IS
	ID	0371090	0371091	0371092	0371093	0371094	0371095
Stroke per jaw	[mm]	6.0	3.0	6.0	3.0	6.0	3.0
Closing force	[N]	250.0	520.0	340.0	710.0		
Opening force	[N]	270.0	565.0			360.0	755.0
Min. spring force	[N]			90.0	190.0	90.0	190.0
Weight	[kg]	0.28	0.28	0.37	0.37	0.37	0.37
Recommended workpiece weight	[kg]	1.25	2.6	1.25	2.6	1.25	2.6
Air consumption per double stroke	[cm <sup>3</sup> ]	9.0	9.0	9.0	9.0	9.0	9.0
Minimum pressure	[bar]	2.5	2.5	4.0	4.0	4.0	4.0
Maximum pressure	[bar]	8.0	8.0	6.5	6.5	6.5	6.5
Nominal pressure	[bar]	6.0	6.0	6.0	6.0	6.0	6.0
Closing Time	[s]	0.03	0.03	0.02	0.02	0.04	0.04
Opening time	[s]	0.03	0.03	0.04	0.04	0.02	0.02
Max. permitted finger length	[mm]	90.0	85.0	85.0	80.0	85.0	80.0
Max. permitted weight per finger	[kg]	0.35	0.35	0.35	0.35	0.35	0.35
IP rating		40	40	40	40	40	40
Min. ambient temperature	[°C]	-10.0	-10.0	-10.0	-10.0	-10.0	-10.0
Température ambiante max.	[°C]	90.0	90.0	90.0	90.0	90.0	90.0
Repeat accuracy	[mm]	0.01	0.01	0.01	0.01	0.01	0.01

### OPTIONS and their characteristics

Dust-protection version	ID	37371090	37371091	37371092	37371093	37371094	37371095
IP rating		64	64	64	64	64	64
Weight	[kg]	0.35	0.35	0.44	0.44	0.44	0.44
Anti-corrosion version	ID	38371090	38371091	38371092	38371093	38371094	38371095
High-temperature version	ID	39371090	39371091	39371092	39371093	39371094	39371095
Min. ambient temperature	[°C]	-10.0	-10.0	-10.0	-10.0	-10.0	-10.0
Température ambiante max.	[°C]	130.0	130.0	130.0	130.0	130.0	130.0
KVZ for increased grip force	ID	0372090	0372091	0372092		0372093	
Description		PGN-plus 64-1-KVZ	PGN-plus 64-2-KVZ	PGN-plus 64-1-AS-KVZ		PGN-plus 64-1-IS-KVZ	
Closing force	[N]	450.0	935.0	540.0			
Opening force	[N]	485.0	1015.0			575.0	
Weight	[kg]	0.35	0.35	0.43		0.43	
Maximum pressure	[bar]	6.0	6.0	6.0		6.0	
Max. permitted finger length	[mm]	80.0	64.0	64.0		64.0	



# PGN-plus 64

Pneumatic · 2-Finger Parallel Gripper · **Universal Gripper**

## Version with dust cover

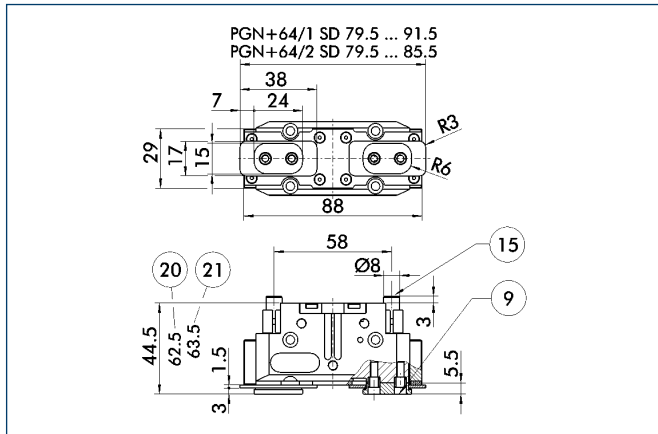

- ⑨ For screw connection diagram, see basic version
- 15 Sealing bolt
- 20 With AS / IS version
- 21 For KVZ version

The „dust-protection“ option increases the degree of protection against penetrating substances. The screw connection diagram shifts by the height of the intermediate jaw. The finger length is still measured from the upper edge of the gripper housing.

## HUE protective cover

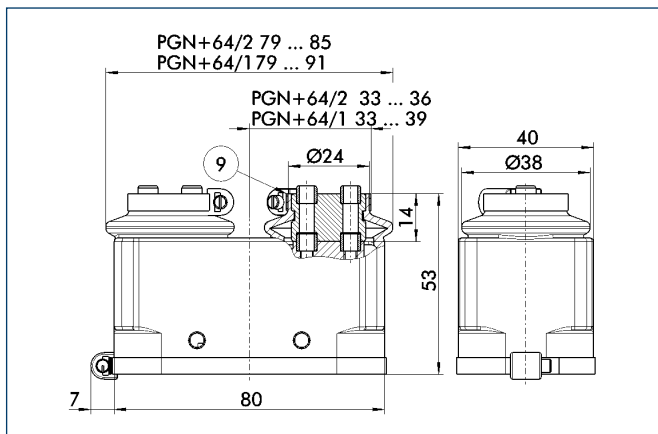

- ⑨ For screw connection diagram, see basic version

The HUE protective cover completely protects the gripper against external influences up to IP65 if an additional sealing of the cover bottom is provided as part of the application. The mounting diagram shifts by the height of the intermediate jaw.

Description	ID
HUE PGN-plus 64	0371480



You can find more detailed information and individual parts of the above-mentioned accessories in the „Accessories“ catalog section.

## KVZ for increased grip force

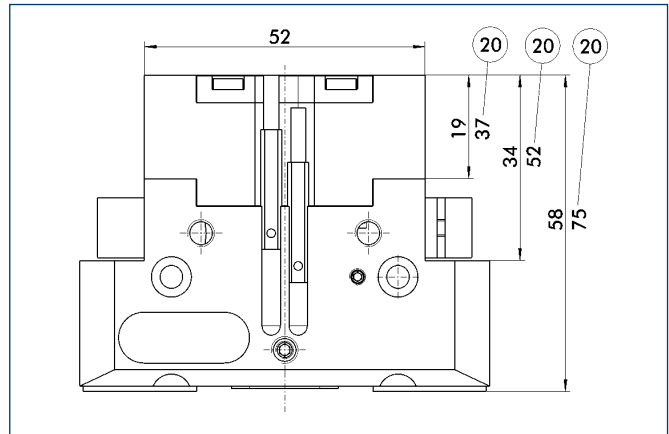

- 20 With AS / IS version

The KVZ cylinder increases the gripping forces during opening and closing. A second, in series-connected piston also increases the force on the wedge hook. The full gripping force shown in the data table is sometimes only reached after a few hundred gripping cycles. Please consider that grippers which are equipped with a gripping force safety device (AS / IS) are higher

## Finger blanks

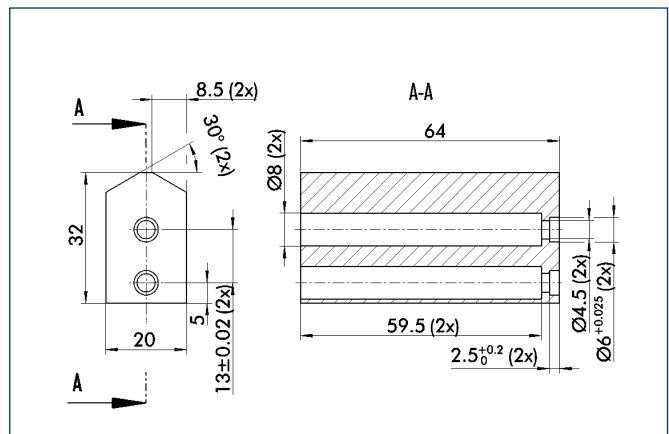

Finger blanks for customized subsequent machining, incl. screw connection diagram

Description	Material	Scope of delivery	ID
ABR-plus 64	Aluminum	1	0300010
SBR-plus 64	16 MnCr 5	1	0300020

### FMS force measuring jaws

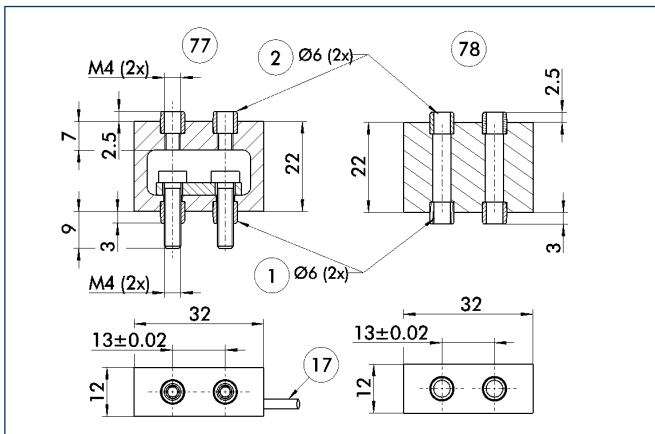

- ① Gripper connection
- ② Finger connection
- ⑰ Cable outlet
- ⑦⑦ Active intermediate jaws
- ⑦⑧ Passiv intermediate jaws

Force measuring jaws measure gripping forces, but can also determine workpiece weights or dimensional deviations. There are active and passive intermediate jaws (FMS-ZBA or FMS-ZBP). At least one active force measuring jaw is required per gripper, the rest can be passive. For each active jaw, an FMS-A1 control unit and an FMS-A connection cable are required.

Description	ID
FMS-A1	0301810
FMS-AKO200	0301820
FMS-AKO500	0301821
FMS-AK1000	0301822
FMS-AK2000	0301823
FMS-ZBA 64	0301832
FMS-ZBP 64	0301833

### BSWS quick-change jaw system

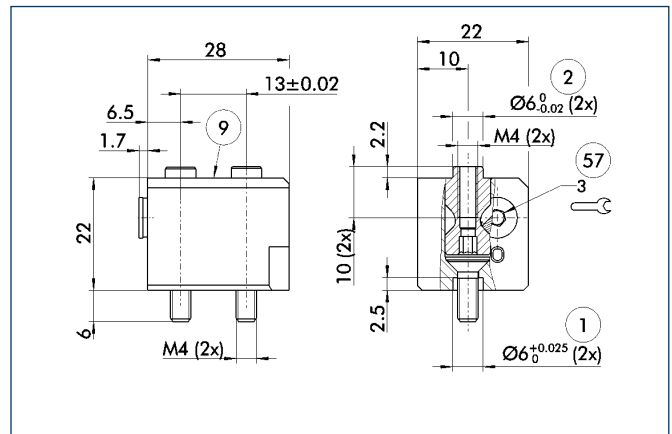

- ① Gripper connection
- ② Finger connection
- ⑨ For screw connection diagram, see basic version
- ⑤⑦ Locking mechanism

The BSWS quick-change jaw system enables top jaws to be changed on the gripper manually and rapidly. An adapter (BSWS-A) and a base (BSWS-B) are required for each gripper jaw.

Description	ID
BSWS-A 64	0303022
BSWS-B 64	0303023



You can find more detailed information and individual parts of the above-mentioned accessories in the „Accessories“ catalog section.

### Sensor system

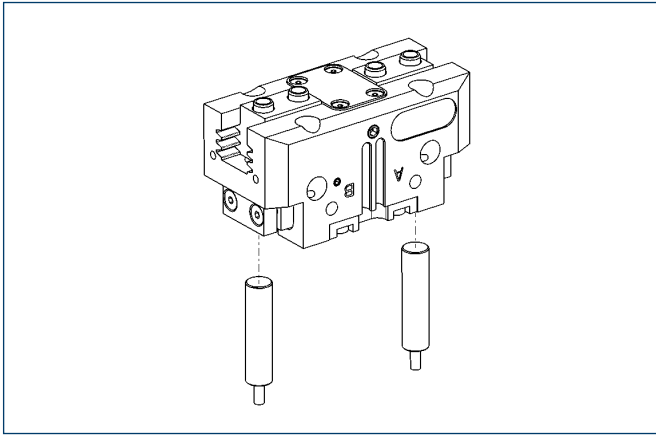

#### End position monitoring:

##### Inductive proximity switches, for direct mounting

Description	ID	Recommended product
IN 80-S-M12	0301578	
IN 80-S-M8	0301478	•
INK 80-S	0301550	

① Two sensors (NO contacts) are required for each gripper, plus extension cables as an option.

#### Extension cables for proximity switches/magnetic switches

Description	ID
KA BG05-L 3P-0300	0301652
KA BG08-L 3P-0300-PNP	0301622
KA BW05-L 3P-0300	0301650
KA BW08-L 3P-0300-NPN	0301602
KA BW08-L 3P-0300-PNP	0301594
KA BW08-L 3P-0500-NPN	9641116
KA BW08-L 3P-0500-PNP	0301502
KA BW12-L 3P-0300-PNP	0301503
KA BW12-L 3P-0500-PNP	0301507
KV BW08-SG08 3P-0030-PNP	0301495
KV BW08-SG08 3P-0100-PNP	0301496
KV BW08-SG08 3P-0200-PNP	0301497
KV BW12-SG12 3P-0030-PNP	0301595
KV BW12-SG12 3P-0100-PNP	0301596
KV BW12-SG12 3P-0200-PNP	0301597

① Please note the minimum permitted bending radii for the sensor cables, which are generally 35 mm.



You can find more detailed information and individual parts of the above-mentioned accessories in the „Accessories“ catalog section.

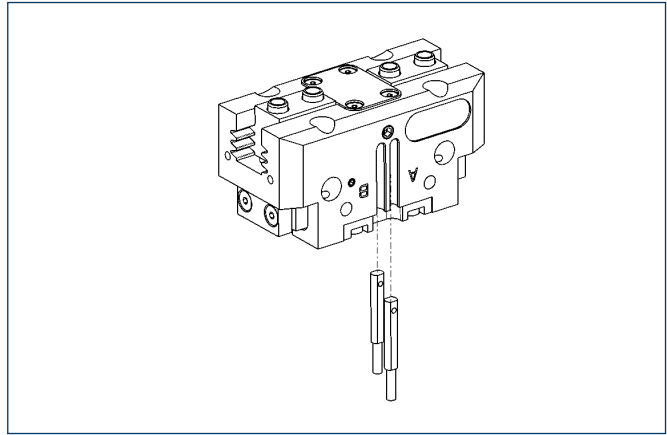

#### End position monitoring:

##### Electronic magnetic switches, for mounting in C-slot

Description	ID	Recommended product
MMS 22-S-M5-NPN	0301439	
MMS 22-S-M5-NPN-SA	0301449	
MMS 22-S-M5-PNP	0301438	
MMS 22-S-M5-PNP-SA	0301448	
MMS 22-S-M8-NPN	0301433	
MMS 22-S-M8-NPN-SA	0301443	
MMS 22-S-M8-PNP	0301432	•
MMS 22-S-M8-PNP-SA	0301442	
MMSK 22-S-NPN	0301435	
MMSK 22-S-NPN-SA	0301445	
MMSK 22-S-PNP	0301434	
MMSK 22-S-PNP-SA	0301444	

① Two sensors (NO contacts) are required for each gripper, plus extension cables as an option.

### Sensor system

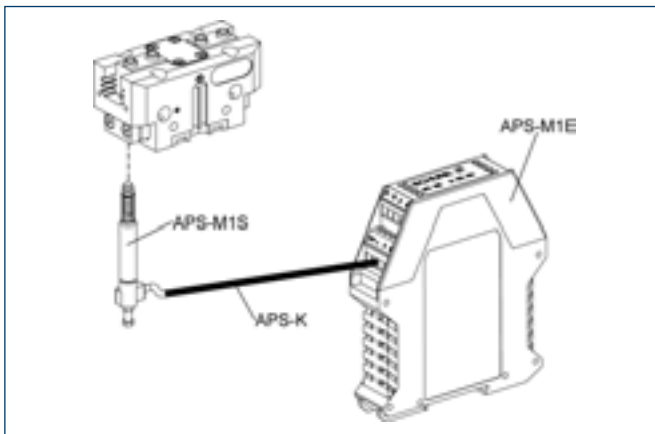

Measuring system:

APS Analog position sensor

Description	ID
APS-K0200	0302066
APS-K0700	0302068
APS-M1E	0302064
APS-M1S	0302062
AS-APS-M1-64/1	0302075

- ① When using an APS system, a mounting kit (AS-APS, incl. 3 m cable), an APS sensor (APS-M1S) and electronics (APS-M1E) are required for each gripper. An extension cable (APS-K) can be connected between the sensor and the electronics as an option. The max. cable length between the sensor and the electronics is 10 m, between the electronics and their control unit (PLC) it is max. 1 m.

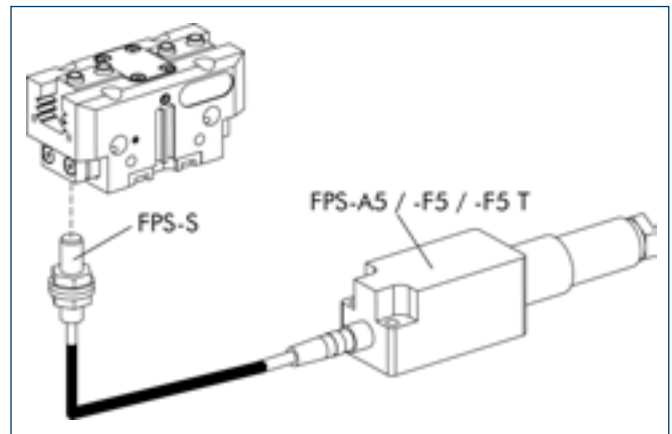

Measuring system:

FPS Flexible position sensor

Description	ID
AS-PGN/PZN-plus 64/1, PGN/PZN-plus 80/2	0301630
FPS-F5	0301805
FPS-F5 T	0301807
FPS-S M8	0301704

- ① When using an FPS system, an FPS sensor (FPS-S) and a control unit (FPS-F5 / F5 T or A5) are required for each gripper as well as a mounting kit (AS), if listed. Cable extensions (KV) are available as options in the „Accessories“ catalog section.

### Maximum permitted finger offset

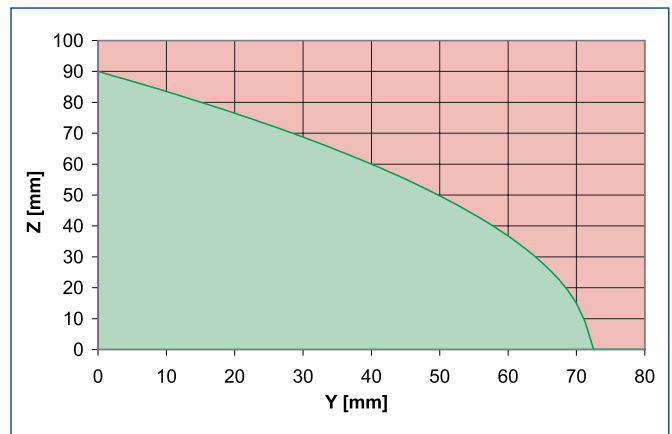
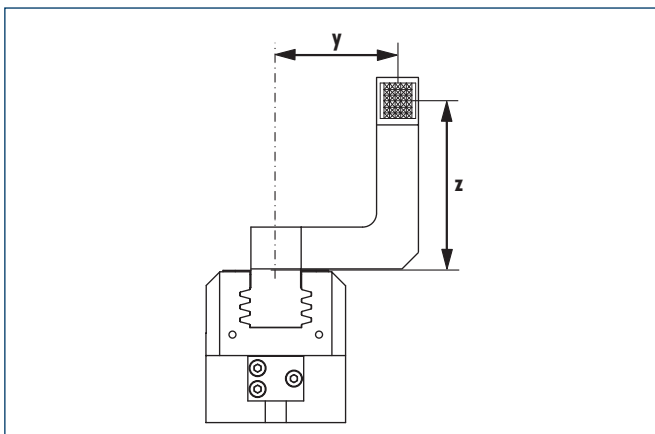

- Permitted range
- Non-permissible range

The curve applies to the basic version (stroke -1). For other versions, the curve will be parallel but offset in line with the max. permitted finger length.



You can find more detailed information and individual parts of the above-mentioned accessories in the „Accessories“ catalog section.



# PGN-plus 80

Pneumatic · 2-Finger Parallel Gripper · **Universal Gripper**



## Gripping force, I.D. gripping

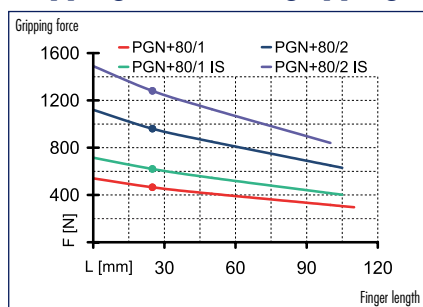

## Gripping force, O.D. gripping

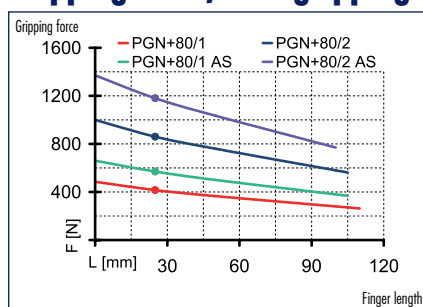

## Finger load

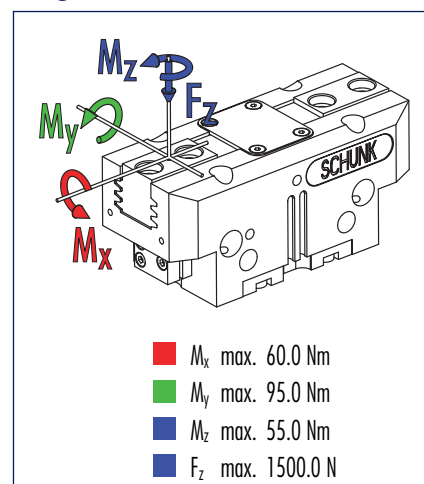

ⓘ Moments and forces apply per base jaw and may occur simultaneously.  $M_y$  may arise in addition to the moment generated by the gripping force itself. If the max. permitted finger weight is exceeded, it is imperative to throttle the air pressure so that the jaw movement occurs without any hitting or bouncing. Service life may reduce.

## Technical data

Description		PGN-plus 80-1	PGN-plus 80-2	PGN-plus 80-1-AS	PGN-plus 80-2-AS	PGN-plus 80-1-IS	PGN-plus 80-2-IS
	ID	0371101	0371151	0371401	0371451	0371461	0371471
Stroke per jaw	[mm]	8.0	4.0	8.0	4.0	8.0	4.0
Closing force	[N]	415.0	860.0	570.0	1180.0		
Opening force	[N]	465.0	960.0			620.0	1280.0
Min. spring force	[N]			155.0	320.0	155.0	320.0
Weight	[kg]	0.5	0.5	0.6	0.6	0.6	0.6
Recommended workpiece weight	[kg]	2.1	4.3	2.1	4.3	2.1	4.3
Air consumption per double stroke	[cm <sup>3</sup> ]	21.0	21.0	21.0	21.0	21.0	21.0
Minimum pressure	[bar]	2.5	2.5	4.0	4.0	4.0	4.0
Maximum pressure	[bar]	8.0	8.0	6.5	6.5	6.5	6.5
Nominal pressure	[bar]	6.0	6.0	6.0	6.0	6.0	6.0
Closing time	[s]	0.04	0.04	0.03	0.03	0.05	0.05
Opening time	[s]	0.04	0.04	0.05	0.05	0.03	0.03
Max. permitted finger length	[mm]	110.0	105.0	105.0	100.0	105.0	100.0
Max. permitted weight per finger	[kg]	0.6	0.6	0.6	0.6	0.6	0.6
IP rating		40	40	40	40	40	40
Min. ambient temperature	[°C]	-10.0	-10.0	-10.0	-10.0	-10.0	-10.0
Température ambiante max.	[°C]	90.0	90.0	90.0	90.0	90.0	90.0
Repeat accuracy	[mm]	0.01	0.01	0.01	0.01	0.01	0.01

### OPTIONS and their characteristics

Dust-protection version	ID	37371101	37371151	37371401	37371451	37371461	37371471
IP rating		64	64	64	64	64	64
Weight	[kg]	0.6	0.6	0.7	0.7	0.7	0.7
Anti-corrosion version	ID	38371101	38371151	38371401	38371451	38371461	38371471
High-temperature version	ID	39371101	39371151	39371401	39371451	39371461	39371471
Min. ambient temperature	[°C]	-10.0	-10.0	-10.0	-10.0	-10.0	-10.0
Température ambiante max.	[°C]	130.0	130.0	130.0	130.0	130.0	130.0
KVZ for increased grip force	ID	0372101	0372151	0372401		0372461	
Description		PGN-plus 80-1-KVZ	PGN-plus 80-2-KVZ	PGN-plus 80-1-AS-KVZ		PGN-plus 80-1-IS-KVZ	
Closing force	[N]	745.0	1550.0	900.0			
Opening force	[N]	835.0	1730.0			990.0	
Weight	[kg]	0.65	0.65	0.75		0.75	
Maximum pressure	[bar]	6.0	6.0	6.0		6.0	
Max. permitted finger length	[mm]	100.0	80.0	80.0		80.0	

### Main views

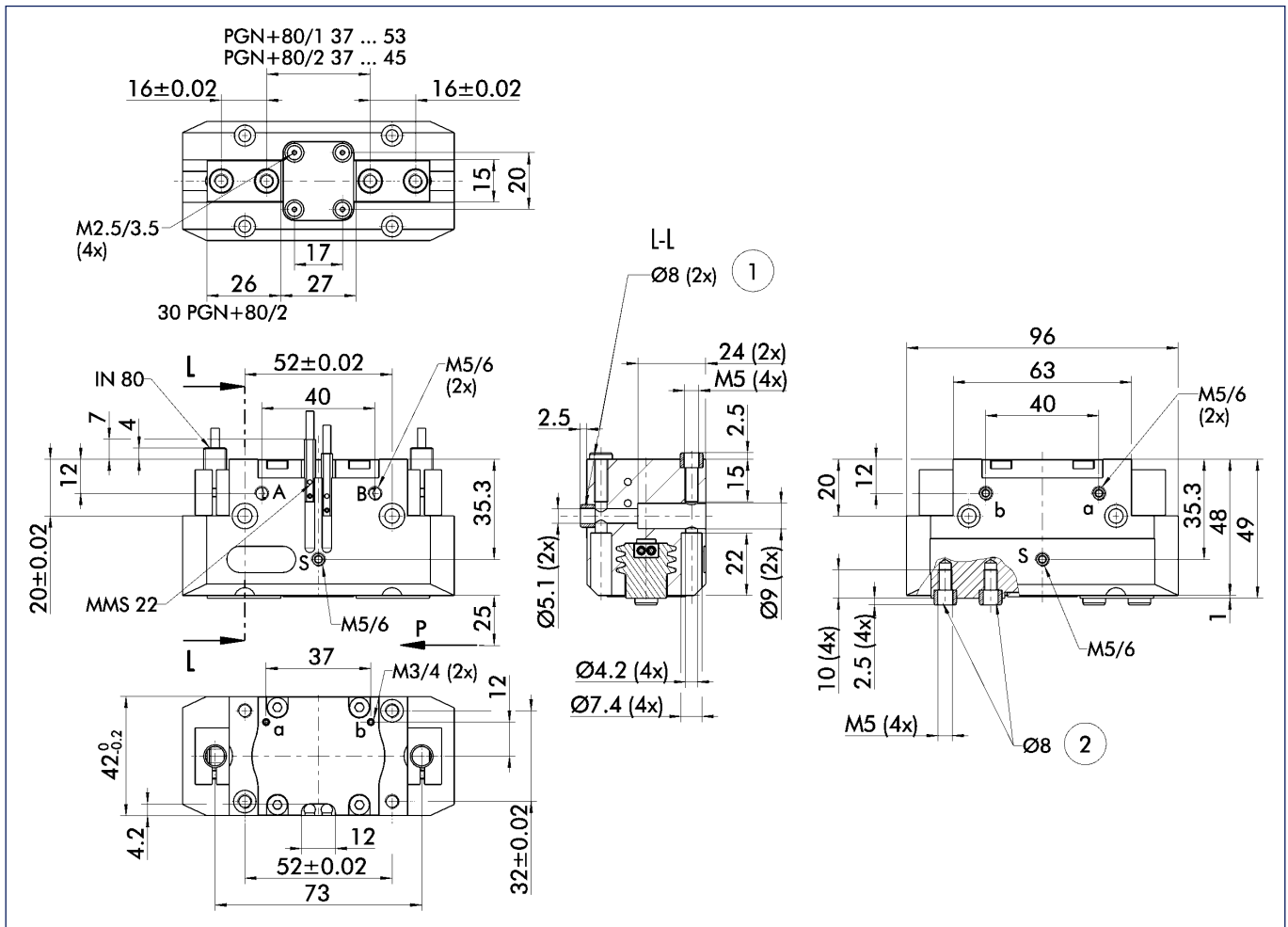

The drawing shows the gripper in the basic version with closed jaws, the dimensions do not include the options described below.

① The SDV-P pressure maintenance valve can also be used (see „Accessories“ catalog section) for I.D. or O.D. gripping as an alternative or in addition to the spring-loaded, mechanical gripping force safety device.

- A,a Main/direct connection, gripper opening
- B,b Main/direct connection, gripper closing
- S,s Air purge or ventilation hole
- ① Gripper connection
- ② Finger connection

### Hose-free direct connection

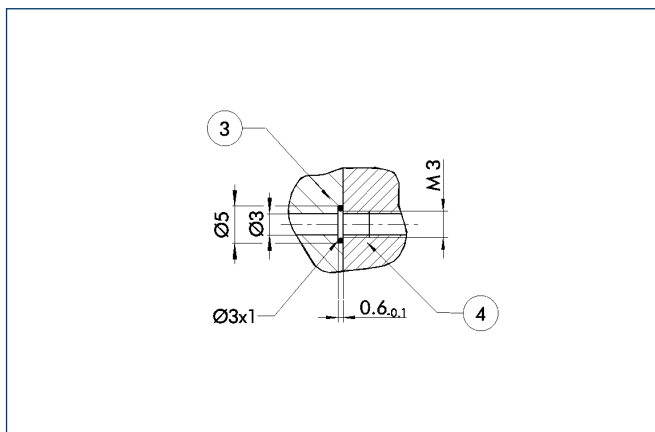

③ Adapter

④ Gripper

The direct connection is used for supplying compressed air to the gripper without hoses. Instead, the pressure medium is fed through bore-holes in the mounting plate.

### AS/IS gripping force safety device

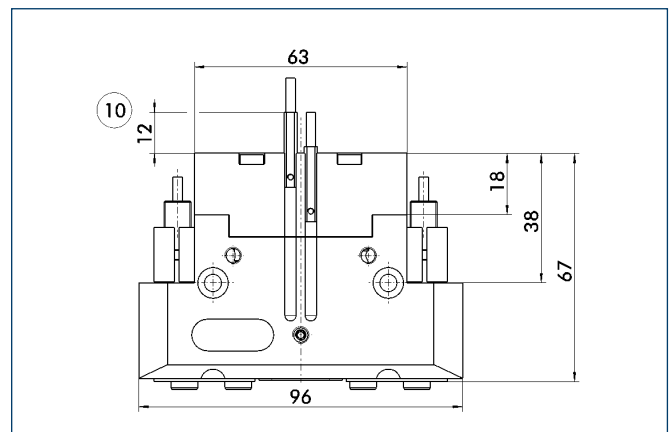

⑩ Projection only with AS version

The mechanical gripping force safety device ensures a minimum gripping force even if there is a drop in pressure. This acts as closing force in the AS version, and as opening force in the IS version. In addition, the gripping force safety device can also be employed as a gripping force booster or for single-acting gripping.

# PGN-plus 80

## Pneumatic · 2-Finger Parallel Gripper · Universal Gripper

### Version with dust cover

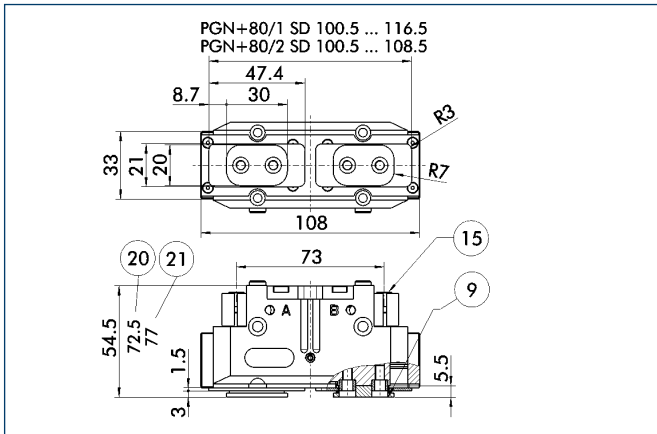

- ⑨ For screw connection diagram, see basic version
- ⑮ Sealing bolt
- ⑳ With AS / IS version
- ㉑ For KVZ version

The „dust-protection“ option increases the degree of protection against penetrating substances. The screw connection diagram shifts by the height of the intermediate jaw. The finger length is still measured from the upper edge of the gripper housing.

### KVZ for increased grip force

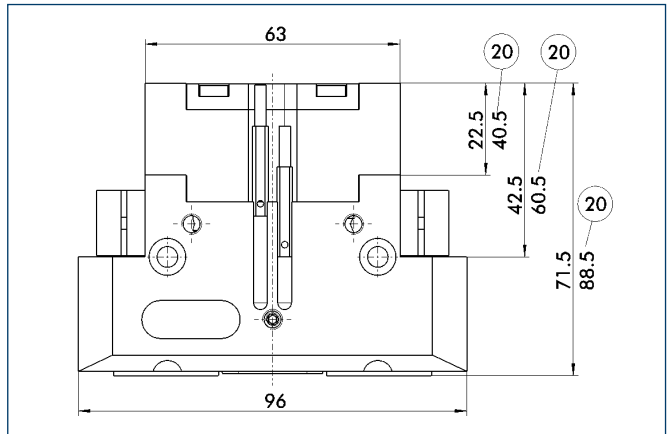

- ㉑ With AS / IS version

The KVZ cylinder increases the gripping forces during opening and closing. A second, in series-connected piston also increases the force on the wedge hook. The full gripping force shown in the data table is sometimes only reached after a few hundred gripping cycles. Please consider that grippers which are equipped with a gripping force safety device (AS / IS) are higher

### HUE protective cover

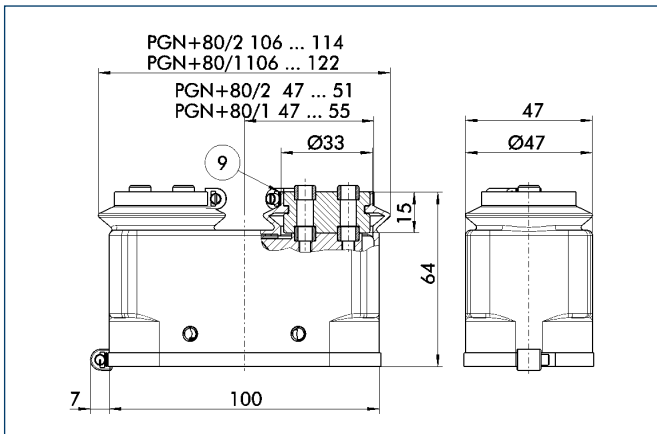

- ⑨ For screw connection diagram, see basic version

The HUE protective cover completely protects the gripper against external influences up to IP65 if an additional sealing of the cover bottom is provided as part of the application. The mounting diagram shifts by the height of the intermediate jaw.

Description	ID
HUE PGN-plus 80	0371481

### Finger blanks

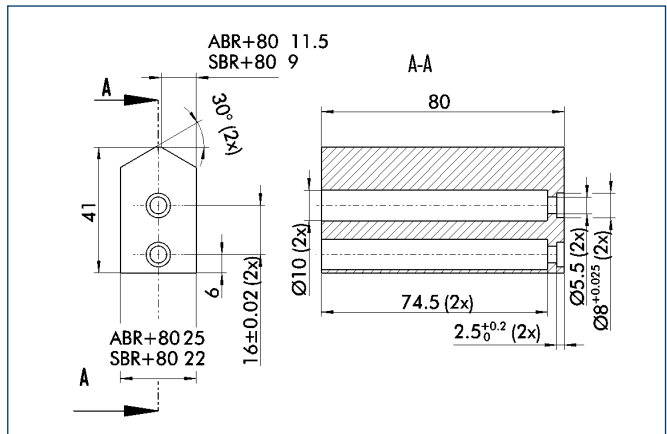

Finger blanks for customized subsequent machining, incl. screw connection diagram

Description	Material	Scope of delivery	ID
ABR-plus 80	Aluminum	1	0300011
SBR-plus 80	16 MnCr 5	1	0300021



You can find more detailed information and individual parts of the above-mentioned accessories in the „Accessories“ catalog section.

### FMS force measuring jaws

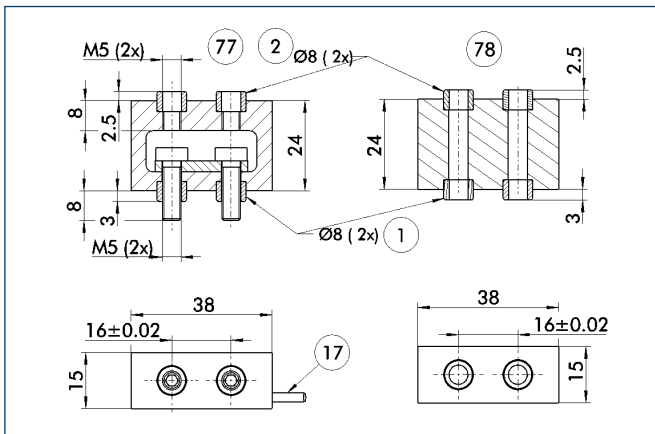

- ① Gripper connection
- ② Finger connection
- ⑰ Cable outlet
- ⑦⑦ Active intermediate jaws
- ⑦⑧ Passiv intermediate jaws

Force measuring jaws measure gripping forces, but can also determine workpiece weights or dimensional deviations. There are active and passive intermediate jaws (FMS-ZBA or FMS-ZBP). At least one active force measuring jaw is required per gripper, the rest can be passive. For each active jaw, an FMS-A1 control unit and an FMS-A connection cable are required.

Description	ID
FMS-A1	0301810
FMS-AKO200	0301820
FMS-AKO500	0301821
FMS-AK1000	0301822
FMS-AK2000	0301823
FMS-ZBA 80	0301834
FMS-ZBP 80	0301835

### BSWS quick-change jaw system

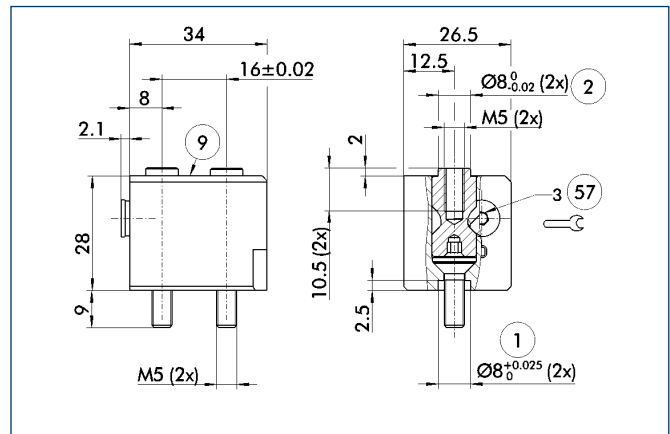

- ① Gripper connection
- ② Finger connection
- ⑨ For screw connection diagram, see basic version
- ⑤⑦ Locking mechanism

The BSWS quick-change jaw system enables top jaws to be changed on the gripper manually and rapidly. An adapter (BSWS-A) and a base (BSWS-B) are required for each gripper jaw.

Description	ID
BSWS-A 80	0303024
BSWS-B 80	0303025



You can find more detailed information and individual parts of the above-mentioned accessories in the „Accessories“ catalog section.

### Sensor system

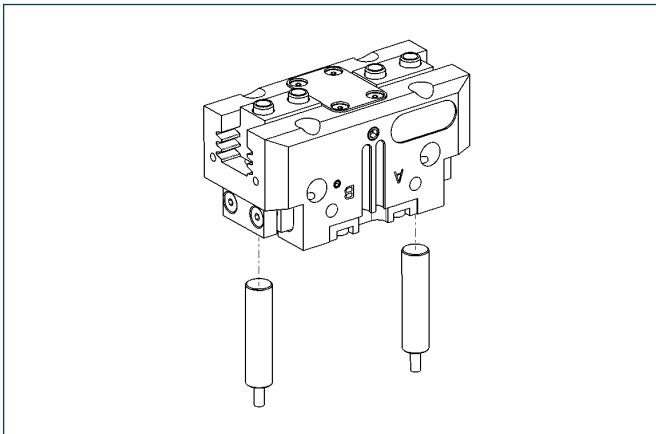

#### End position monitoring:

##### Inductive proximity switches, for direct mounting

Description	ID	Recommended product
IN 80-S-M12	0301578	
IN 80-S-M8	0301478	•
IN-C 80-S-M8	0301475	
INK 80-S	0301550	

① Two sensors (NO contacts) are required for each gripper, plus extension cables as an option.

#### Extension cables for proximity switches/magnetic switches

Description	ID
KA BG05-L 3P-0300	0301652
KA BG08-L 3P-0300-PNP	0301622
KA BW05-L 3P-0300	0301650
KA BW08-L 3P-0300-NPN	0301602
KA BW08-L 3P-0300-PNP	0301594
KA BW08-L 3P-0500-NPN	9641116
KA BW08-L 3P-0500-PNP	0301502
KA BW12-L 3P-0300-PNP	0301503
KA BW12-L 3P-0500-PNP	0301507
KV BW08-SG08 3P-0030-PNP	0301495
KV BW08-SG08 3P-0100-PNP	0301496
KV BW08-SG08 3P-0200-PNP	0301497
KV BW12-SG12 3P-0030-PNP	0301595
KV BW12-SG12 3P-0100-PNP	0301596
KV BW12-SG12 3P-0200-PNP	0301597

① Please note the minimum permitted bending radii for the sensor cables, which are generally 35 mm.

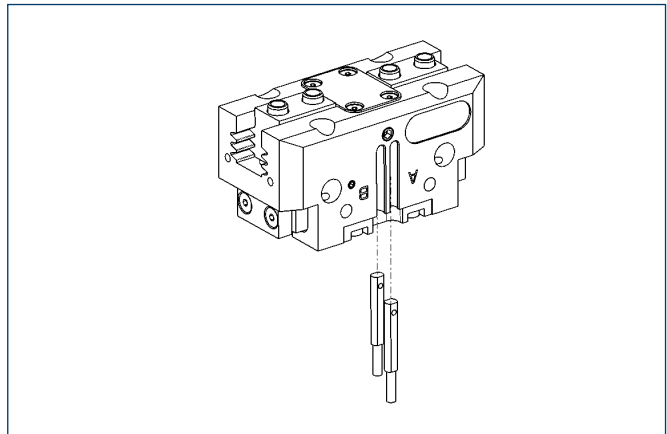

#### End position monitoring:

##### Electronic magnetic switches, for mounting in C-slot

Description	ID	Recommended product
MMS 22-S-M5-NPN	0301439	
MMS 22-S-M5-NPN-SA	0301449	
MMS 22-S-M5-PNP	0301438	
MMS 22-S-M5-PNP-SA	0301448	
MMS 22-S-M8-NPN	0301433	
MMS 22-S-M8-NPN-SA	0301443	
MMS 22-S-M8-PNP	0301432	•
MMS 22-S-M8-PNP-SA	0301442	
MMSK 22-S-NPN	0301435	
MMSK 22-S-NPN-SA	0301445	
MMSK 22-S-PNP	0301434	
MMSK 22-S-PNP-SA	0301444	

① Two sensors (NO contacts) are required for each gripper, plus extension cables as an option.



You can find more detailed information and individual parts of the above-mentioned accessories in the „Accessories“ catalog section.

### Sensor system

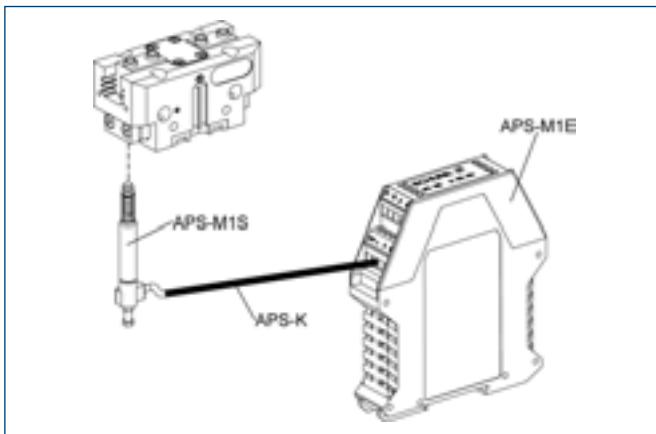

Measuring system:

APS Analog position sensor

Description	ID
APS-K0200	0302066
APS-K0700	0302068
APS-M1E	0302064
APS-M1S	0302062
AS-APS-M1-80/1	0302077
AS-APS-M1-80/2	0302078

- ① When using an APS system, a mounting kit (AS-APS, incl. 3 m cable), an APS sensor (APS-M1S) and electronics (APS-M1E) are required for each gripper. An extension cable (APS-K) can be connected between the sensor and the electronics as an option. The max. cable length between the sensor and the electronics is 10 m, between the electronics and their control unit (PLC) it is max. 1 m.

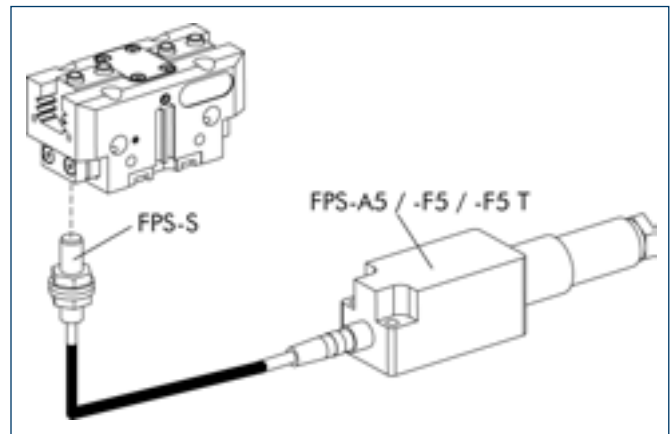

Measuring system:

FPS Flexible position sensor

Description	ID
AS-PGN-plus/PZN-plus 80/1, PZB 80/100	0301632
AS-PGN/PZN-plus 64/1, PGN/PZN-plus 80/2	0301630
FPS-F5	0301805
FPS-F5 T	0301807
FPS-S M8	0301704

- ① When using an FPS system, an FPS sensor (FPS-S) and an control unit (FPS-F5 / F5 T or A5) are required for each gripper as well as a mounting kit (AS), if listed. Cable extensions (KV) are available as options in the „Accessories“ catalog section.

### Maximum permitted finger offset

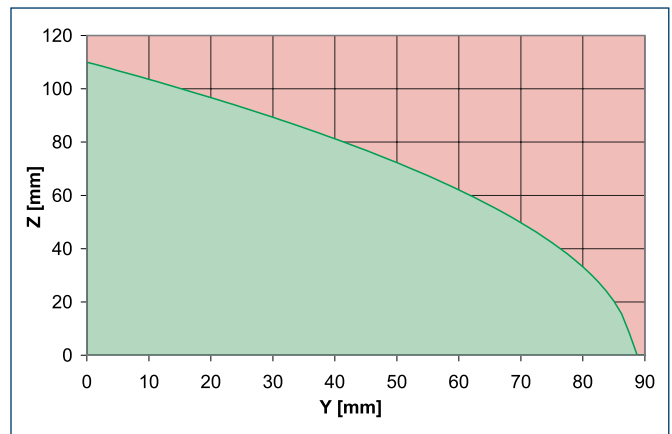
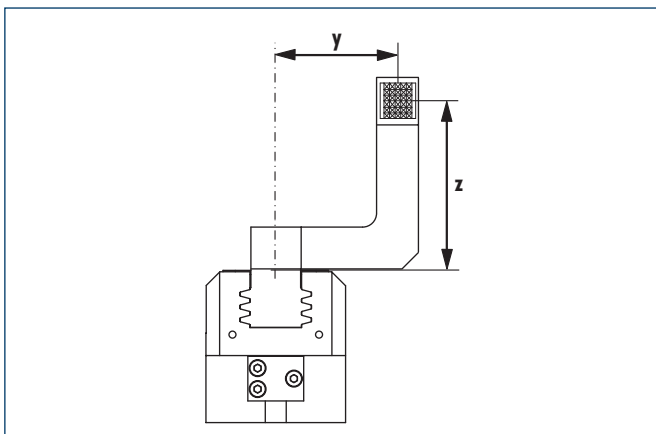

- Permitted range
- Non-permissible range

The curve applies to the basic version (stroke -1). For other versions, the curve will be parallel but offset in line with the max. permitted finger length.



You can find more detailed information and individual parts of the above-mentioned accessories in the „Accessories“ catalog section.

# PGN-plus 100

Pneumatic · 2-Finger Parallel Gripper · Universal Gripper



## Gripping force, I.D. gripping

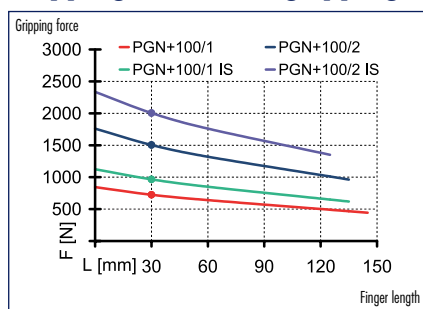

## Gripping force, O.D. gripping

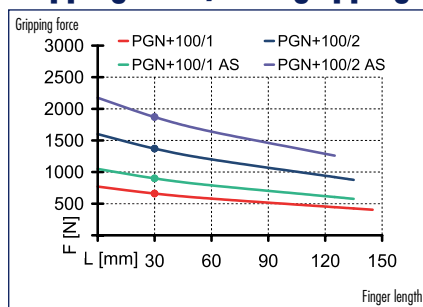

## Finger load

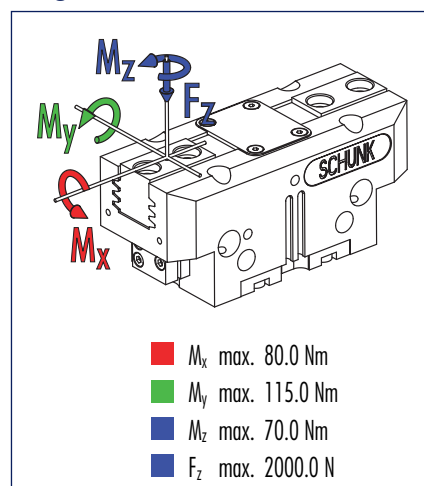

ⓘ Moments and forces apply per base jaw and may occur simultaneously.  $M_y$  may arise in addition to the moment generated by the gripping force itself. If the max. permitted finger weight is exceeded, it is imperative to throttle the air pressure so that the jaw movement occurs without any hitting or bouncing. Service life may reduce.

## Technical data

Description		PGN-plus 100-1	PGN-plus 100-2	PGN-plus 100-1-AS	PGN-plus 100-2-AS	PGN-plus 100-1-IS	PGN-plus 100-2-IS
	ID	0371102	0371152	0371402	0371452	0371462	0371472
Stroke per jaw	[mm]	10.0	5.0	10.0	5.0	10.0	5.0
Closing force	[N]	660.0	1370.0	900.0	1870.0		
Opening force	[N]	725.0	1500.0			965.0	1740.0
Min. spring force	[N]			240.0	500.0	240.0	240.0
Weight	[kg]	0.81	0.81	1.0	1.0	1.0	1.0
Recommended workpiece weight	[kg]	3.3	6.85	3.3	6.85	3.3	6.85
Air consumption per double stroke	[cm <sup>3</sup> ]	40.0	40.0	40.0	40.0	40.0	40.0
Minimum pressure	[bar]	2.5	2.5	4.0	4.0	4.0	4.0
Maximum pressure	[bar]	8.0	8.0	6.5	6.5	6.5	6.5
Nominal pressure	[bar]	6.0	6.0	6.0	6.0	6.0	6.0
Closing time	[s]	0.07	0.07	0.05	0.05	0.09	0.09
Opening time	[s]	0.07	0.07	0.09	0.09	0.05	0.05
Max. permitted finger length	[mm]	145.0	135.0	135.0	125.0	135.0	125.0
Max. permitted weight per finger	[kg]	1.1	1.1	1.1	1.1	1.1	1.1
IP rating		40	40	40	40	40	40
Min. ambient temperature	[°C]	-10.0	-10.0	-10.0	-10.0	-10.0	-10.0
Température ambiante max.	[°C]	90.0	90.0	90.0	90.0	90.0	90.0
Repeat accuracy	[mm]	0.01	0.01	0.01	0.01	0.01	0.01

### OPTIONS and their characteristics

Dust-protection version	ID	37371102	37371152	37371402	37371452	37371462	37371472
IP rating		64	64	64	64	64	64
Weight	[kg]	0.99	0.99	1.18	1.18	1.18	1.18
Anti-corrosion version	ID	38371102	38371152	38371402	38371452	38371462	38371472
High-temperature version	ID	39371102	39371152	39371402	39371452	39371462	39371472
Min. ambient temperature	[°C]	-10.0	-10.0	-10.0	-10.0	-10.0	-10.0
Température ambiante max.	[°C]	130.0	130.0	130.0	130.0	130.0	130.0
KVZ for increased grip force	ID	0372102	0372152	0372402		0372462	
Description		PGN-plus 100-1-KVZ	PGN-plus 100-2-KVZ	PGN-plus 100-1-AS-KVZ		PGN-plus 100-1-IS-KVZ	
Closing force	[N]	1190.0	2465.0	1430.0			
Opening force	[N]	1305.0	2700.0			1545.0	
Weight	[kg]	1.05	1.05	1.3		1.3	
Maximum pressure	[bar]	6.0	6.0	6.0		6.0	
Max. permitted finger length	[mm]	125.0	100.0	100.0		100.0	



### Main views

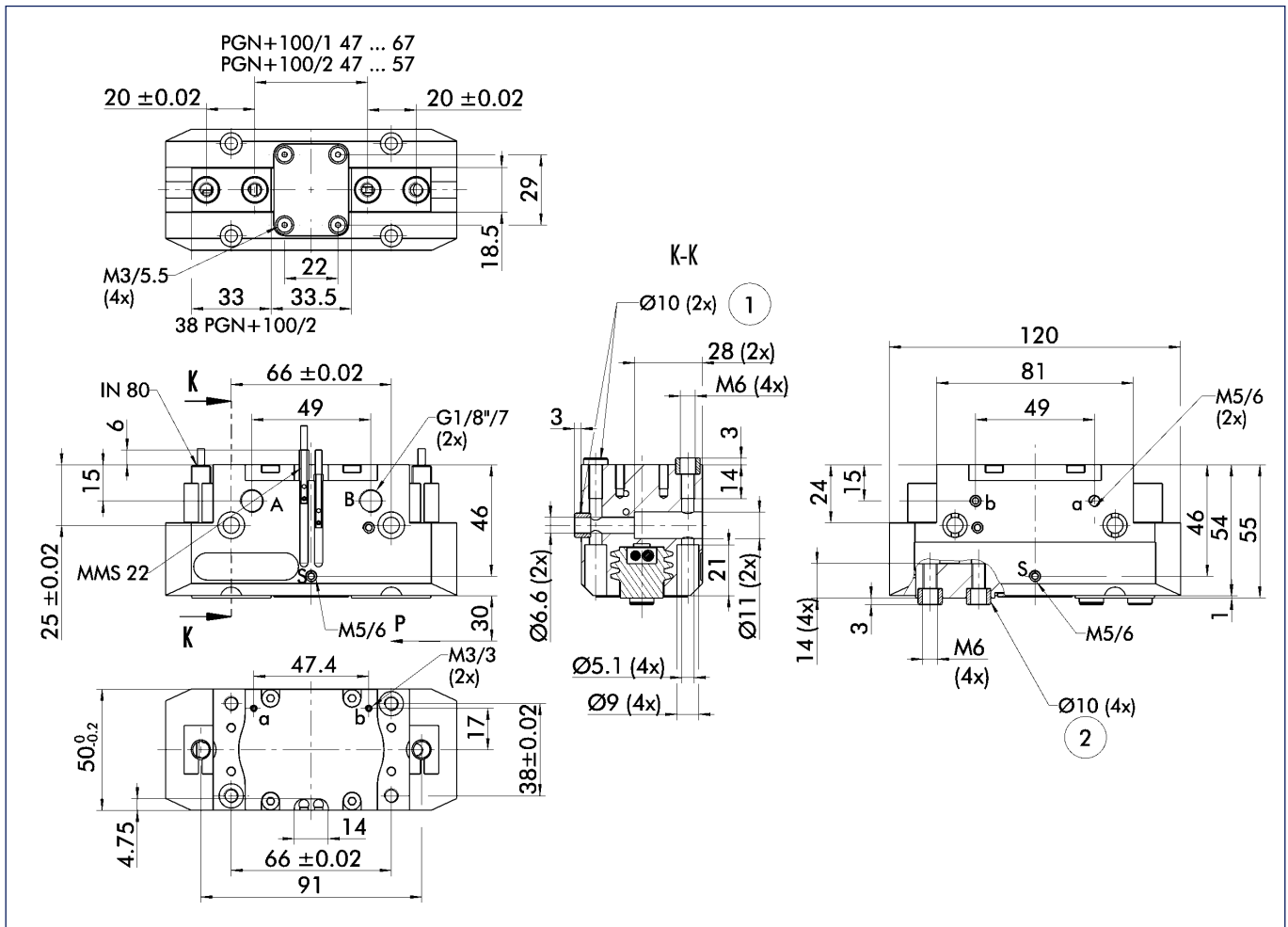

The drawing shows the gripper in the basic version with closed jaws, the dimensions do not include the options described below.

① The SDV-P pressure maintenance valve can also be used (see „Accessories“ catalog section) for I.D. or O.D. gripping as an alternative or in addition to the spring-loaded, mechanical gripping force safety device.

- A,a Main/direct connection, gripper opening
- B,b Main/direct connection, gripper closing
- S,s Air purge or ventilation hole
- ① Gripper connection
- ② Finger connection

### Hose-free direct connection

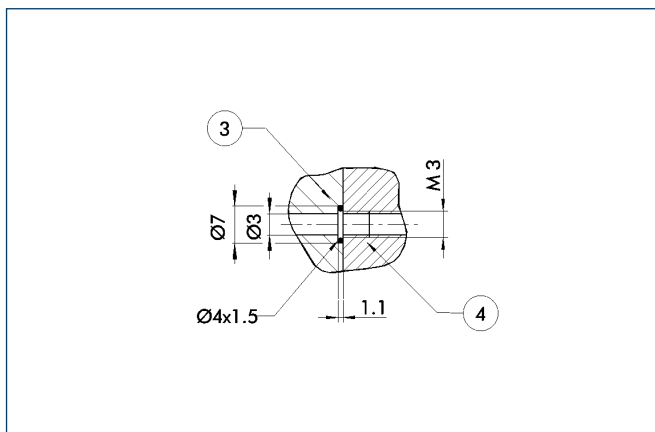

③ Adapter

④ Gripper

The direct connection is used for supplying compressed air to the gripper without hoses. Instead, the pressure medium is fed through bore-holes in the mounting plate.

### AS/IS gripping force safety device

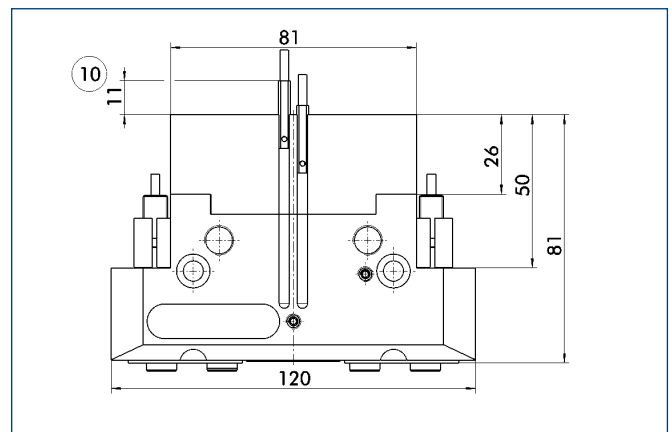

⑩ Projection only with AS version

The mechanical gripping force safety device ensures a minimum gripping force even if there is a drop in pressure. This acts as closing force in the AS version, and as opening force in the IS version. In addition, the gripping force safety device can also be employed as a gripping force booster or for single-acting gripping.

# PGN-plus 100

Pneumatic · 2-Finger Parallel Gripper · Universal Gripper

## Version with dust cover

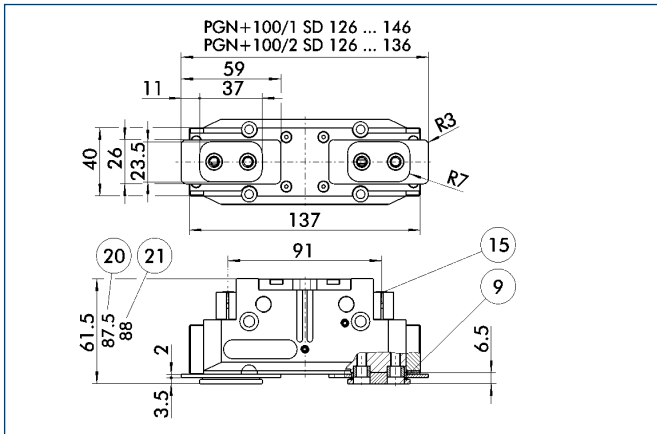

- ⑨ For screw connection diagram, see basic version
- ⑮ Sealing bolt
- ⑳ With AS / IS version
- ㉑ For KVZ version

The „dust-protection“ option increases the degree of protection against penetrating substances. The screw connection diagram shifts by the height of the intermediate jaw. The finger length is still measured from the upper edge of the gripper housing.

## KVZ for increased grip force

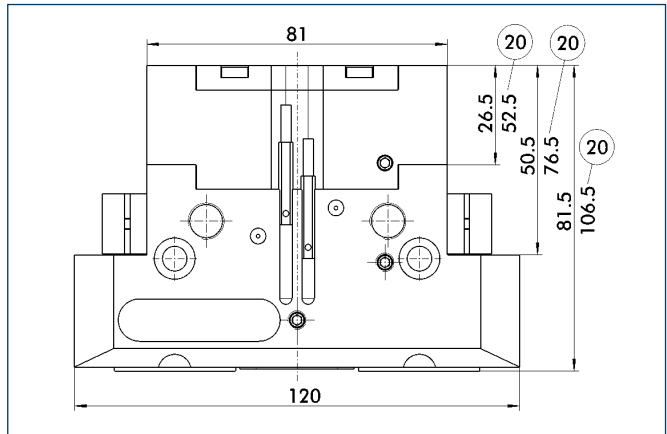

- ㉒ With AS / IS version

The KVZ cylinder increases the gripping forces during opening and closing. A second, in series-connected piston also increases the force on the wedge hook. The full gripping force shown in the data table is sometimes only reached after a few hundred gripping cycles. Please consider that grippers which are equipped with a gripping force safety device (AS / IS) are higher

## HUE protective cover

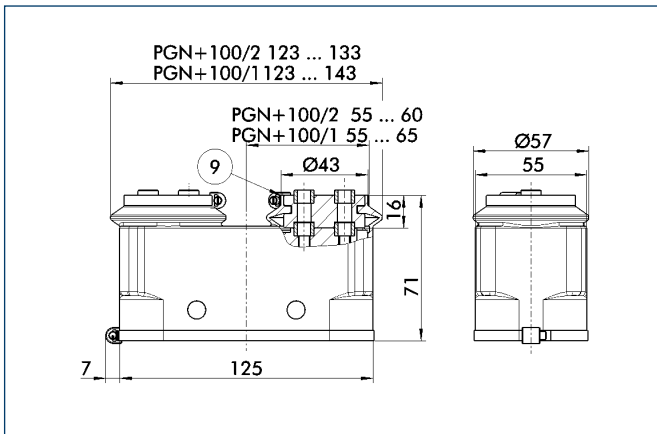

- ⑨ For screw connection diagram, see basic version

The HUE protective cover completely protects the gripper against external influences up to IP65 if an additional sealing of the cover bottom is provided as part of the application. The mounting diagram shifts by the height of the intermediate jaw.

Description	ID
HUE PGN-plus 100	0371482

## Finger blanks

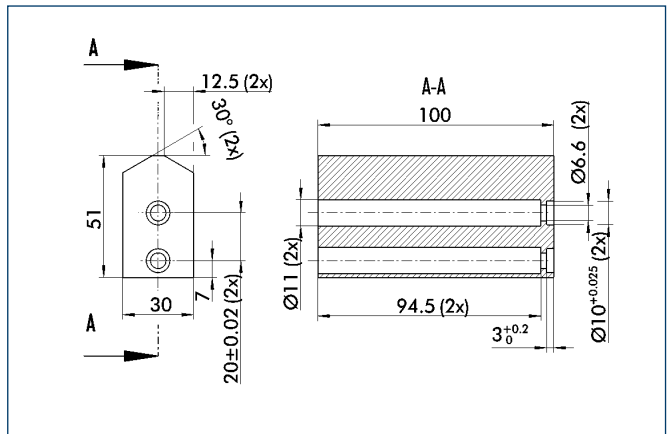

Finger blanks for customized subsequent machining, incl. screw connection diagram

Description	Material	Scope of delivery	ID
ABR-plus 100	Aluminum	1	0300012
SBR-plus 100	16 MnCr 5	1	0300022



You can find more detailed information and individual parts of the above-mentioned accessories in the „Accessories“ catalog section.

### FMS force measuring jaws

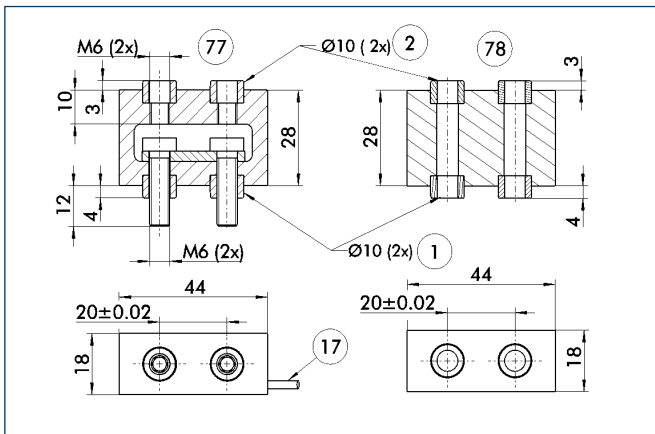

- ① Gripper connection
- ② Finger connection
- ⑰ Cable outlet
- ⑦⑦ Active intermediate jaws
- ⑦⑧ Passiv intermediate jaws

Force measuring jaws measure gripping forces, but can also determine workpiece weights or dimensional deviations. There are active and passive intermediate jaws (FMS-ZBA or FMS-ZBP). At least one active force measuring jaw is required per gripper, the rest can be passive. For each active jaw, an FMS-A1 control unit and an FMS-A connection cable are required.

Description	ID
FMS-A1	0301810
FMS-AK0200	0301820
FMS-AK0500	0301821
FMS-AK1000	0301822
FMS-AK2000	0301823
FMS-ZBA 100	0301836
FMS-ZBP 100	0301837

### BSWS quick-change jaw system

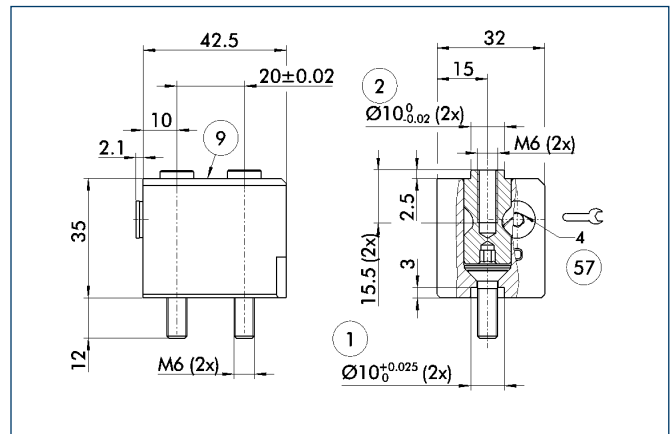

- ① Gripper connection
- ② Finger connection
- ⑨ For screw connection diagram, see basic version
- ⑤⑦ Locking mechanism

The BSWS quick-change jaw system enables top jaws to be changed on the gripper manually and rapidly. An adapter (BSWS-A) and a base (BSWS-B) are required for each gripper jaw.

Description	ID
BSWS-A 100	0303026
BSWS-B 100	0303027



You can find more detailed information and individual parts of the above-mentioned accessories in the „Accessories“ catalog section.

### Sensor system

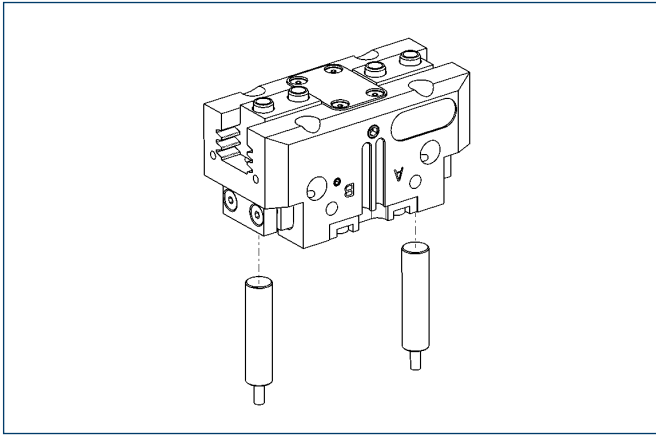

#### End position monitoring:

##### Inductive proximity switches, for direct mounting

Description	ID	Recommended product
IN 80-S-M12	0301578	
IN 80-S-M8	0301478	•
IN-C 80-S-M8	0301475	
INK 80-S	0301550	

① Two sensors (NO contacts) are required for each gripper, plus extension cables as an option.

#### Extension cables for proximity switches/magnetic switches

Description	ID
KA BG05-L 3P-0300	0301652
KA BG08-L 3P-0300-PNP	0301622
KA BW05-L 3P-0300	0301650
KA BW08-L 3P-0300-NPN	0301602
KA BW08-L 3P-0300-PNP	0301594
KA BW08-L 3P-0500-NPN	9641116
KA BW08-L 3P-0500-PNP	0301502
KA BW12-L 3P-0300-PNP	0301503
KA BW12-L 3P-0500-PNP	0301507
KV BW08-SG08 3P-0030-PNP	0301495
KV BW08-SG08 3P-0100-PNP	0301496
KV BW08-SG08 3P-0200-PNP	0301497
KV BW12-SG12 3P-0030-PNP	0301595
KV BW12-SG12 3P-0100-PNP	0301596
KV BW12-SG12 3P-0200-PNP	0301597

① Please note the minimum permitted bending radii for the sensor cables, which are generally 35 mm.

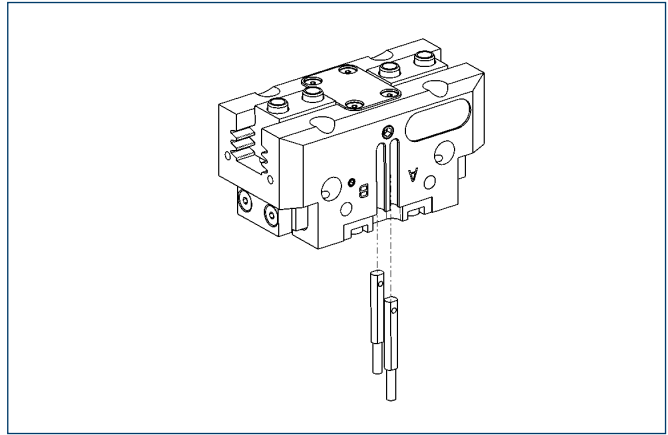

#### End position monitoring:

##### Electronic magnetic switches, for mounting in C-slot

Description	ID	Recommended product
MMS 22-S-M5-NPN	0301439	
MMS 22-S-M5-NPN-SA	0301449	
MMS 22-S-M5-PNP	0301438	
MMS 22-S-M5-PNP-SA	0301448	
MMS 22-S-M8-NPN	0301433	
MMS 22-S-M8-NPN-SA	0301443	
MMS 22-S-M8-PNP	0301432	•
MMS 22-S-M8-PNP-SA	0301442	
MMSK 22-S-NPN	0301435	
MMSK 22-S-NPN-SA	0301445	
MMSK 22-S-PNP	0301434	
MMSK 22-S-PNP-SA	0301444	

① Two sensors (NO contacts) are required for each gripper, plus extension cables as an option.



You can find more detailed information and individual parts of the above-mentioned accessories in the „Accessories“ catalog section.

### Sensor system

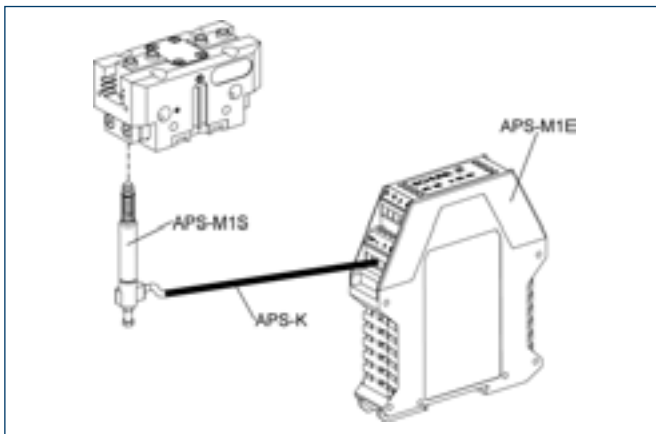

Measuring system:

APS Analog position sensor

Description	ID
APS-K0200	0302066
APS-K0700	0302068
APS-M1E	0302064
APS-M1S	0302062
AS-APS-M1-100/1	0302079
AS-APS-M1-100/2	0302080

- ① When using an APS system, a mounting kit (AS-APS, incl. 3 m cable), an APS sensor (APS-M1S) and electronics (APS-M1E) are required for each gripper. An extension cable (APS-K) can be connected between the sensor and the electronics as an option. The max. cable length between the sensor and the electronics is 10 m, between the electronics and their control unit (PLC) it is max. 1 m.

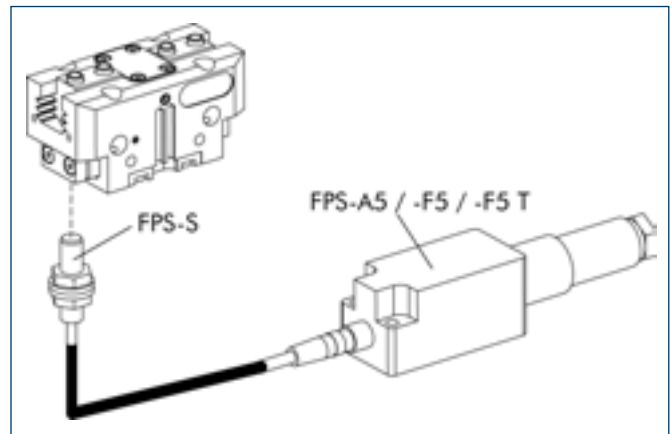

Measuring system:

FPS Flexible position sensor

Description	ID
AS-PGN/PZN-plus 100/1	0301634
AS-PGN/PZN-plus 100/2, PZB 125	0301635
FPS-F5	0301805
FPS-F5 T	0301807
FPS-S M8	0301704

- ① When using an FPS system, an FPS sensor (FPS-S) and a control unit (FPS-F5 / F5 T or A5) are required for each gripper as well as a mounting kit (AS), if listed. Cable extensions (KV) are available as options in the „Accessories“ catalog section.

### Maximum permitted finger offset

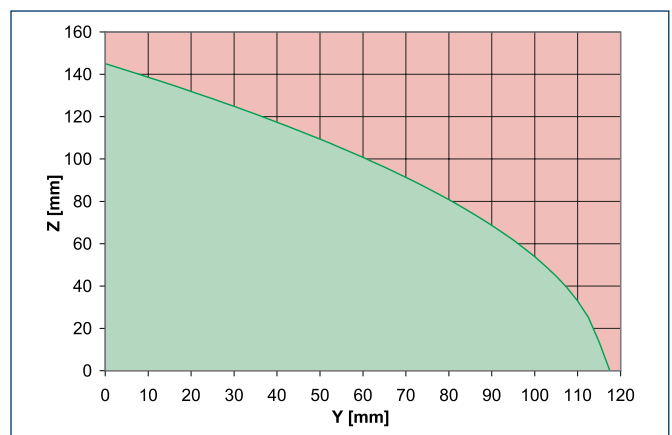
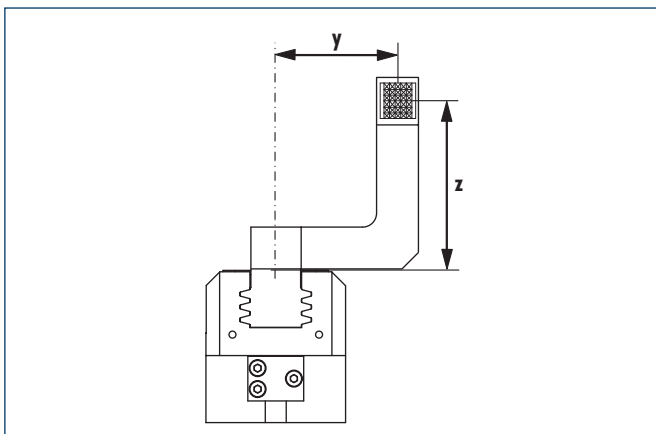

- Permitted range
- Non-permissible range

The curve applies to the basic version (stroke -1). For other versions, the curve will be parallel but offset in line with the max. permitted finger length.



You can find more detailed information and individual parts of the above-mentioned accessories in the „Accessories“ catalog section.

# PGN-plus 125

Pneumatic · 2-Finger Parallel Gripper · **Universal Gripper**

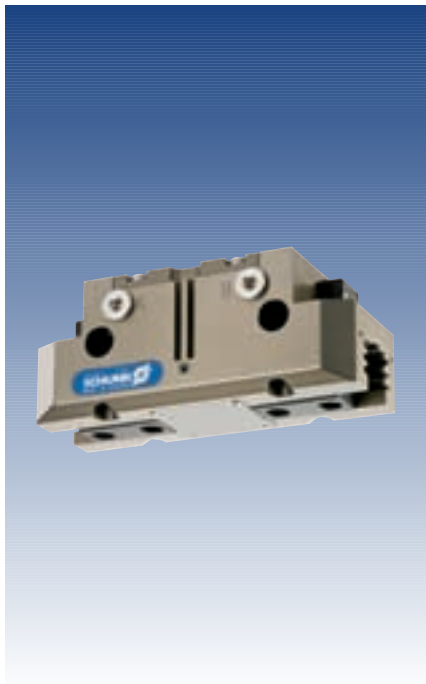

## Gripping force, I.D. gripping

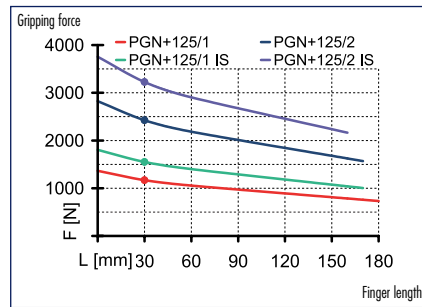

## Gripping force, O.D. gripping

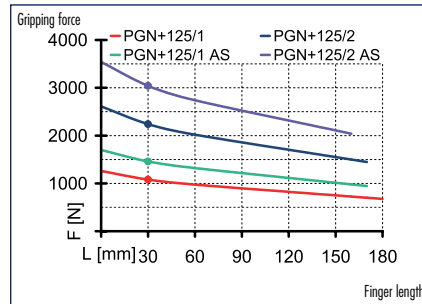

## Finger load

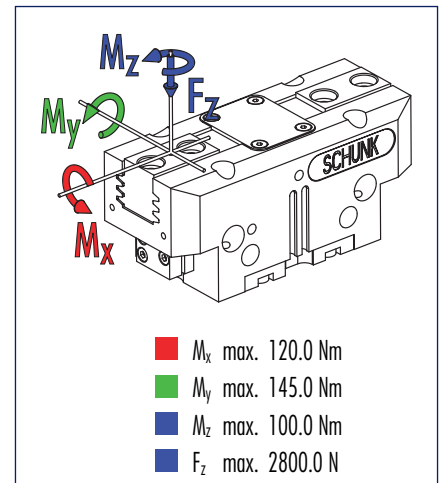

① Moments and forces apply per base jaw and may occur simultaneously.  $M_y$  may arise in addition to the moment generated by the gripping force itself. If the max. permitted finger weight is exceeded, it is imperative to throttle the air pressure so that the jaw movement occurs without any hitting or bouncing. Service life may reduce.

## Technical data

Description		PGN-plus 125-1	PGN-plus 125-2	PGN-plus 125-1-AS	PGN-plus 125-2-AS	PGN-plus 125-1-IS	PGN-plus 125-2-IS
	ID	0371103	0371153	0371403	0371453	0371463	0371473
Stroke per jaw	[mm]	13.0	6.0	13.0	6.0	13.0	6.0
Closing force	[N]	1080.0	2240.0	1470.0	3040.0		
Opening force	[N]	1170.0	2420.0			1560.0	3220.0
Min. spring force	[N]			390.0	800.0	390.0	800.0
Weight	[kg]	1.35	1.35	1.85	1.85	1.85	1.85
Recommended workpiece weight	[kg]	5.4	11.2	5.4	11.2	5.4	11.2
Air consumption per double stroke	[cm <sup>3</sup> ]	81.0	81.0	81.0	81.0	81.0	81.0
Minimum pressure	[bar]	2.5	2.5	4.0	4.0	4.0	4.0
Maximum pressure	[bar]	8.0	8.0	6.5	6.5	6.5	6.5
Nominal pressure	[bar]	6.0	6.0	6.0	6.0	6.0	6.0
Closing time	[s]	0.1	0.1	0.08	0.08	0.12	0.12
Opening time	[s]	0.1	0.1	0.12	0.12	0.08	0.08
Max. permitted finger length	[mm]	180.0	170.0	170.0	160.0	170.0	160.0
Max. permitted weight per finger	[kg]	2.1	2.1	2.1	2.1	2.1	2.1
IP rating		40	40	40	40	40	40
Min. ambient temperature	[°C]	-10.0	-10.0	-10.0	-10.0	-10.0	-10.0
Température ambiante max.	[°C]	90.0	90.0	90.0	90.0	90.0	90.0
Repeat accuracy	[mm]	0.01	0.01	0.01	0.01	0.01	0.01

### OPTIONS and their characteristics

Dust-protection version	ID	37371103	37371153	37371403	37371453	37371463	37371473
IP rating		64	64	64	64	64	64
Weight	[kg]	1.55	1.55	2.05	2.05	2.05	2.05
Anti-corrosion version	ID	38371103	38371153	38371403	38371453	38371463	38371473
High-temperature version	ID	39371103	39371153	39371403	39371453	39371463	39371473
Min. ambient temperature	[°C]	-10.0	-10.0	-10.0	-10.0	-10.0	-10.0
Température ambiante max.	[°C]	130.0	130.0	130.0	130.0	130.0	130.0
KVZ for increased grip force	ID	0372103	0372153	0372403		0372463	
Description		PGN-plus 125-1-KVZ	PGN-plus 125-2-KVZ	PGN-plus 125-1-AS-KVZ		PGN-plus 125-1-IS-KVZ	
Closing force	[N]	1945.0	4030.0	2335.0			
Opening force	[N]	2105.0	4355.0			2495.0	
Weight	[kg]	1.85	1.85	2.3		2.3	
Maximum pressure	[bar]	6.0	6.0	6.0		6.0	
Max. permitted finger length	[mm]	160.0	125.0	125.0		125.0	

### Main views

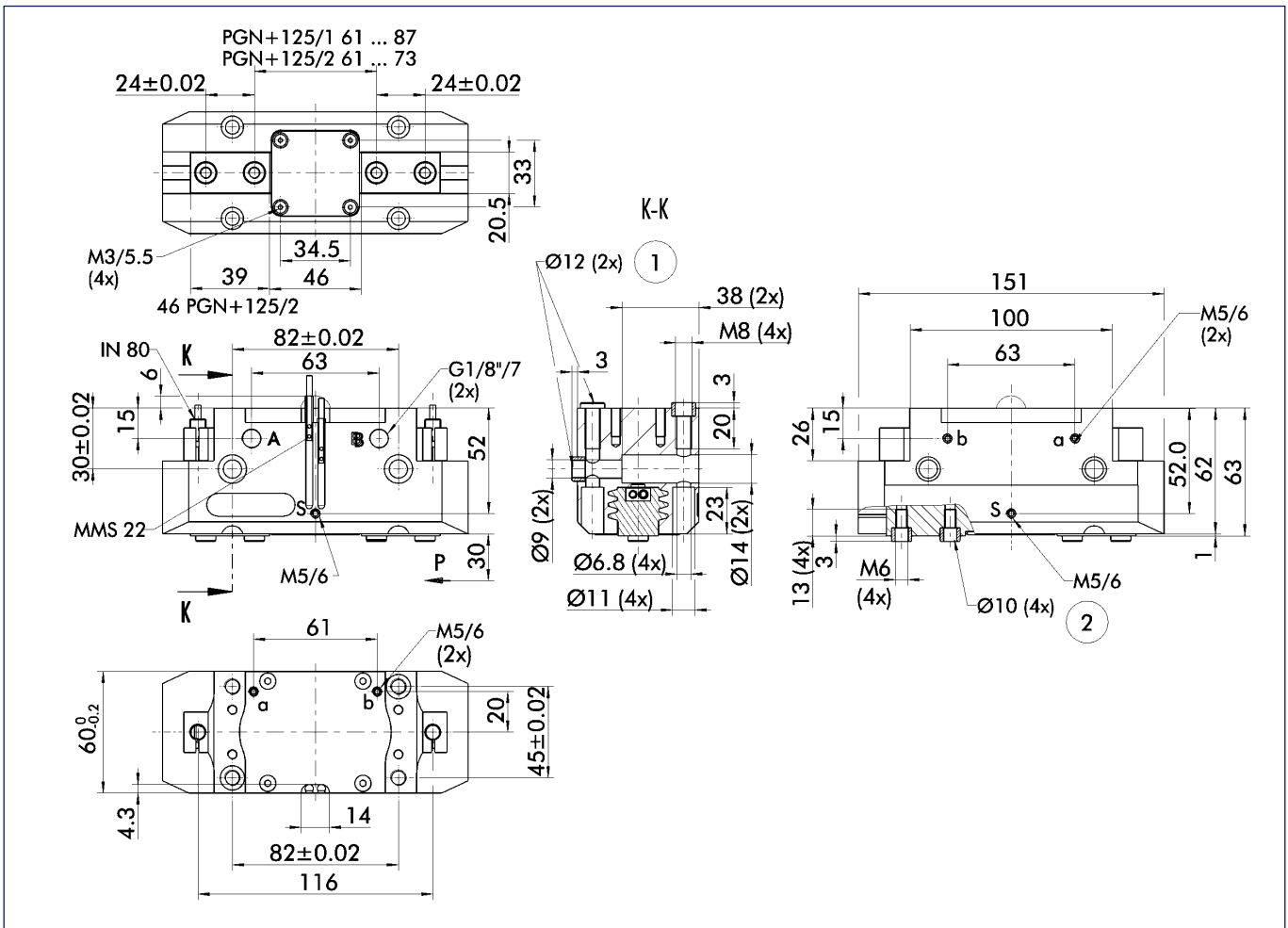

The drawing shows the gripper in the basic version with closed jaws, the dimensions do not include the options described below.

① The SDV-P pressure maintenance valve can also be used (see „Accessories“ catalog section) for I.D. or O.D. gripping as an alternative or in addition to the spring-loaded, mechanical gripping force safety device.

- A,a Main/direct connection, gripper opening
- B,b Main/direct connection, gripper closing
- S,s Air purge or ventilation hole
- ① Gripper connection
- ② Finger connection

### Hose-free direct connection

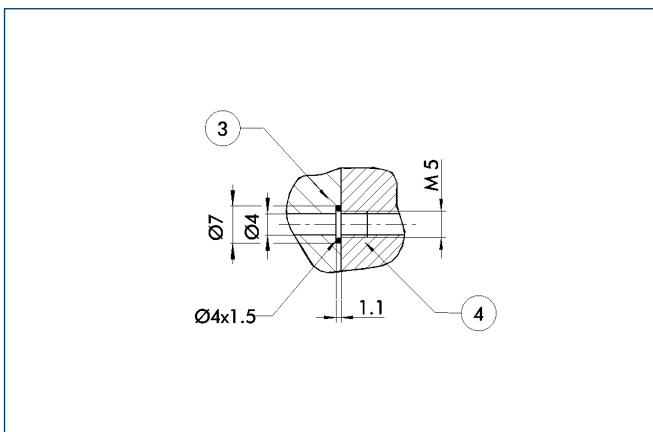

- ③ Adapter
- ④ Gripper

The direct connection is used for supplying compressed air to the gripper without hoses. Instead, the pressure medium is fed through bore-holes in the mounting plate.

### AS/IS gripping force safety device

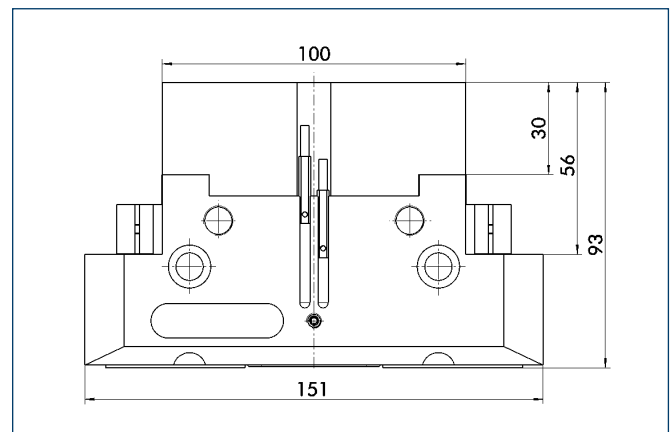

The mechanical gripping force safety device ensures a minimum gripping force even if there is a drop in pressure. This acts as closing force in the AS version, and as opening force in the IS version. In addition, the gripping force safety device can also be employed as a gripping force booster or for single-acting gripping.





### FMS force measuring jaws

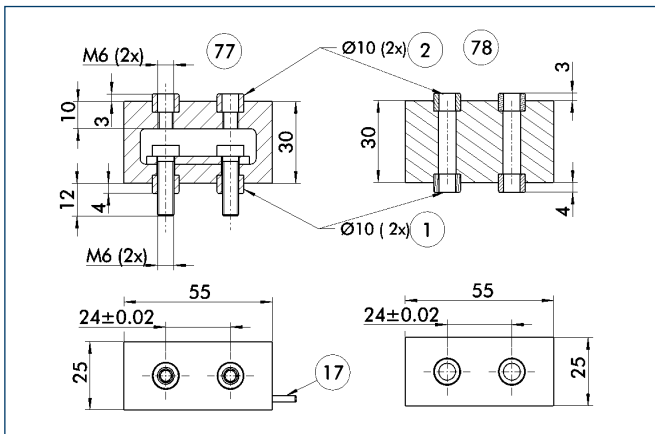

- ① Gripper connection
- ② Finger connection
- ⑰ Cable outlet
- ⑦⑦ Active intermediate jaws
- ⑦⑧ Passiv intermediate jaws

Force measuring jaws measure gripping forces, but can also determine workpiece weights or dimensional deviations. There are active and passive intermediate jaws (FMS-ZBA or FMS-ZBP). At least one active force measuring jaw is required per gripper, the rest can be passive. For each active jaw, an FMS-A1 control unit and an FMS-A connection cable are required.

Description	ID
FMS-A1	0301810
FMS-AK0200	0301820
FMS-AK0500	0301821
FMS-AK1000	0301822
FMS-AK2000	0301823
FMS-ZBA 125	0301838
FMS-ZBP 125	0301839

### BSWS quick-change jaw system

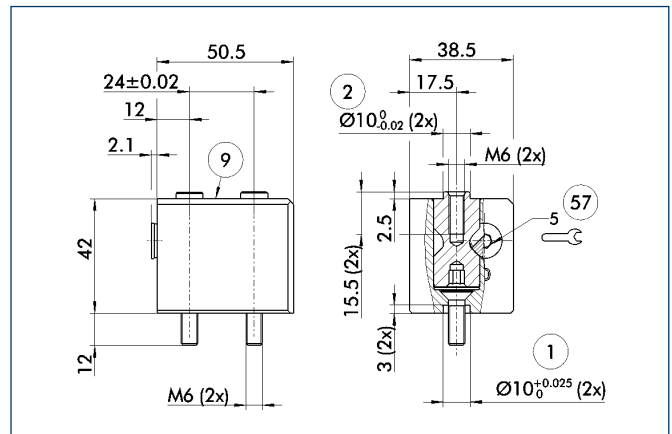

- ① Gripper connection
- ② Finger connection
- ⑨ For screw connection diagram, see basic version
- ⑤⑦ Locking mechanism

The BSWS quick-change jaw system enables top jaws to be changed on the gripper manually and rapidly. An adapter (BSWS-A) and a base (BSWS-B) are required for each gripper jaw.

Description	ID
BSWS-A 125	0303028
BSWS-B 125	0303029



You can find more detailed information and individual parts of the above-mentioned accessories in the „Accessories“ catalog section.

### Sensor system

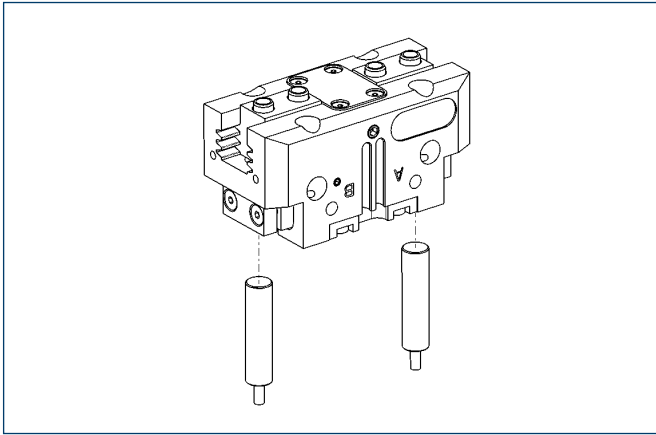

#### End position monitoring:

##### Inductive proximity switches, for direct mounting

Description	ID	Recommended product
IN 80-S-M12	0301578	
IN 80-S-M8	0301478	•
INK 80-S	0301550	

① Two sensors (NO contacts) are required for each gripper, plus extension cables as an option.

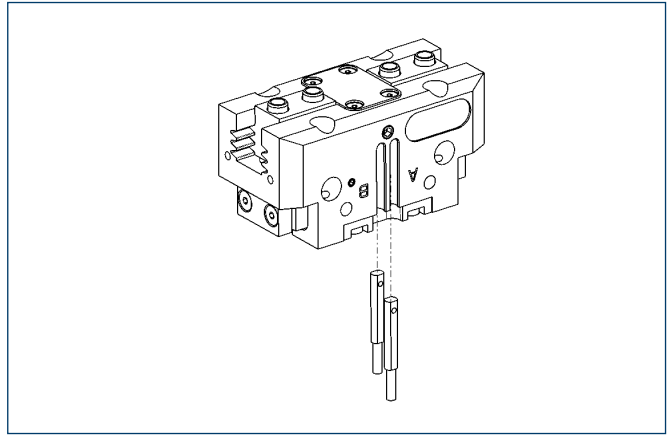

#### End position monitoring:

##### Electronic magnetic switches, for mounting in C-slot

Description	ID	Recommended product
MMS 22-S-M5-NPN	0301439	
MMS 22-S-M5-NPN-SA	0301449	
MMS 22-S-M5-PNP	0301438	
MMS 22-S-M5-PNP-SA	0301448	
MMS 22-S-M8-NPN	0301433	
MMS 22-S-M8-NPN-SA	0301443	
MMS 22-S-M8-PNP	0301432	•
MMS 22-S-M8-PNP-SA	0301442	
MMSK 22-S-NPN	0301435	
MMSK 22-S-NPN-SA	0301445	
MMSK 22-S-PNP	0301434	
MMSK 22-S-PNP-SA	0301444	

① Two sensors (NO contacts) are required for each gripper, plus extension cables as an option.

#### Extension cables for proximity switches/magnetic switches

Description	ID
KA BG05-L 3P-0300	0301652
KA BG08-L 3P-0300-PNP	0301622
KA BW05-L 3P-0300	0301650
KA BW08-L 3P-0300-NPN	0301602
KA BW08-L 3P-0300-PNP	0301594
KA BW08-L 3P-0500-NPN	9641116
KA BW08-L 3P-0500-PNP	0301502
KA BW12-L 3P-0300-PNP	0301503
KA BW12-L 3P-0500-PNP	0301507
KV BW08-SG08 3P-0030-PNP	0301495
KV BW08-SG08 3P-0100-PNP	0301496
KV BW08-SG08 3P-0200-PNP	0301497
KV BW12-SG12 3P-0030-PNP	0301595
KV BW12-SG12 3P-0100-PNP	0301596
KV BW12-SG12 3P-0200-PNP	0301597

① Please note the minimum permitted bending radii for the sensor cables, which are generally 35 mm.



You can find more detailed information and individual parts of the above-mentioned accessories in the „Accessories“ catalog section.

### Sensor system

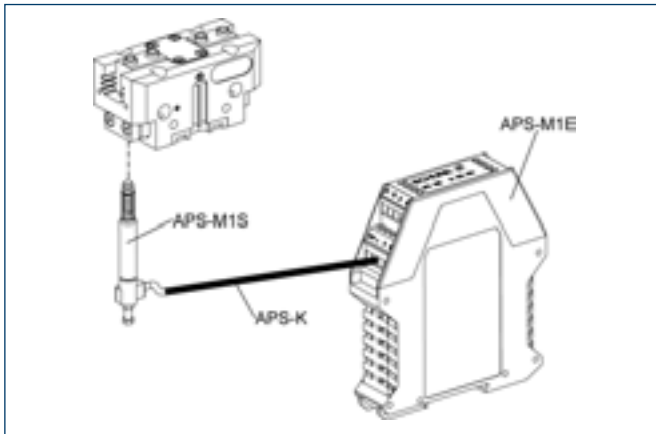

Measuring system:

APS Analog position sensor

Description	ID
APS-K0200	0302066
APS-K0700	0302068
APS-M1E	0302064
APS-M1S	0302062
AS-APS-M1-125/1	0302081
AS-APS-M1-125/2	0302082

- ① When using an APS system, a mounting kit (AS-APS, incl. 3 m cable), an APS sensor (APS-M1S) and electronics (APS-M1E) are required for each gripper. An extension cable (APS-K) can be connected between the sensor and the electronics as an option. The max. cable length between the sensor and the electronics is 10 m, between the electronics and their control unit (PLC) it is max. 1 m.

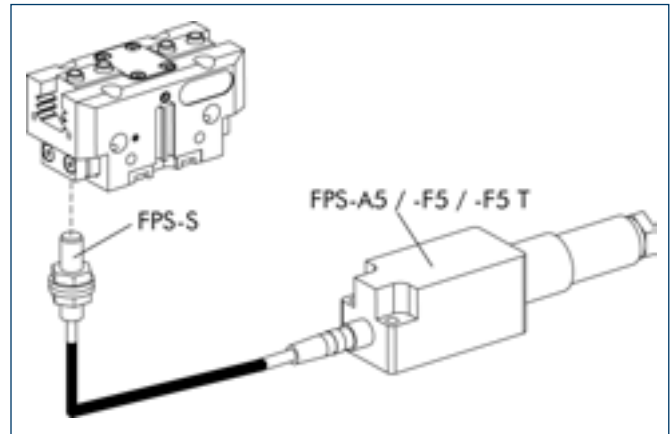

Measuring system:

FPS Flexible position sensor

Description	ID
AS-PGN/PZN-plus 125/1, PZB 160	0301636
AS-PGN/PZN-plus 125/2	0301637
FPS-F5	0301805
FPS-F5 T	0301807
FPS-S M8	0301704

- ① When using an FPS system, an FPS sensor (FPS-S) and a control unit (FPS-F5 / F5 T or A5) are required for each gripper as well as a mounting kit (AS), if listed. Cable extensions (KV) are available as options in the „Accessories“ catalog section.

### Maximum permitted finger offset

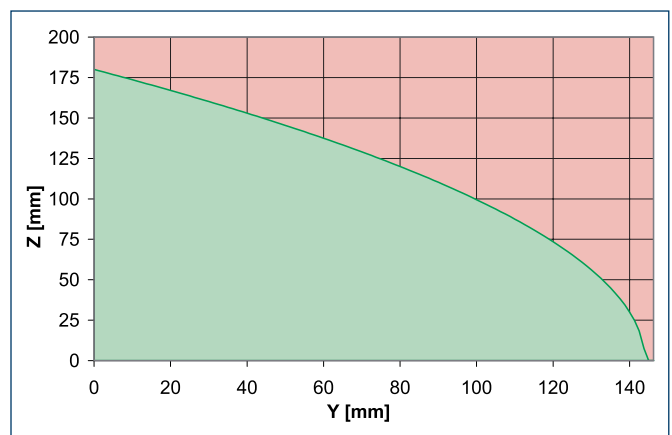
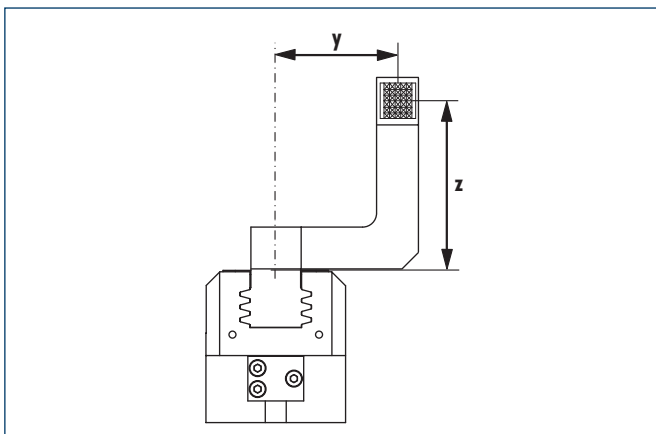

- Permitted range
- Non-permissible range

The curve applies to the basic version (stroke -1). For other versions, the curve will be parallel but offset in line with the max. permitted finger length.



You can find more detailed information and individual parts of the above-mentioned accessories in the „Accessories“ catalog section.

# PGN-plus 160

Pneumatic · 2-Finger Parallel Gripper · Universal Gripper



## Gripping force, I.D. gripping

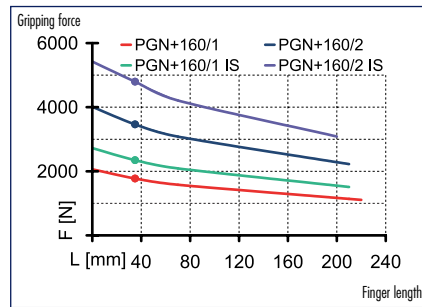

## Gripping force, O.D. gripping

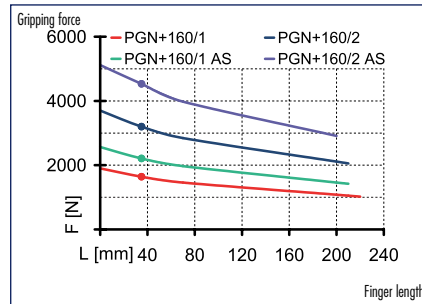

## Finger load

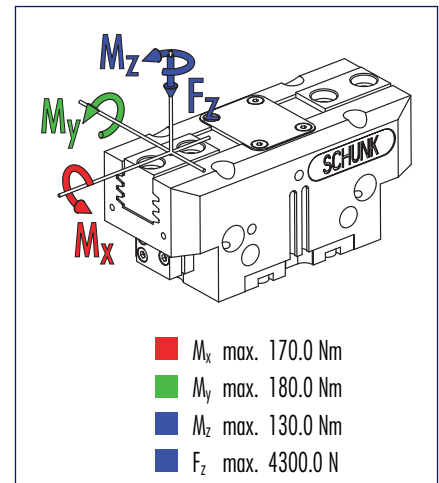

① Moments and forces apply per base jaw and may occur simultaneously.  $M_y$  may arise in addition to the moment generated by the gripping force itself. If the max. permitted finger weight is exceeded, it is imperative to throttle the air pressure so that the jaw movement occurs without any hitting or bouncing. Service life may reduce.

## Technical data

Description		PGN-plus 160-1	PGN-plus 160-2	PGN-plus 160-1-AS	PGN-plus 160-2-AS	PGN-plus 160-1-IS	PGN-plus 160-2-IS
ID		0371104	0371154	0371404	0371454	0371464	0371474
Stroke per jaw	[mm]	16.0	8.0	16.0	8.0	16.0	8.0
Closing force	[N]	1640.0	3200.0	2210.0	4420.0		
Opening force	[N]	1770.0	3460.0			2340.0	4680.0
Min. spring force	[N]			570.0	1220.0	570.0	1220.0
Weight	[kg]	2.6	2.6	3.3	3.3	3.3	3.3
Recommended workpiece weight	[kg]	8.2	16.0	8.2	16.0	8.2	16.0
Air consumption per double stroke	[cm <sup>3</sup> ]	157.0	157.0	157.0	157.0	157.0	157.0
Minimum pressure	[bar]	2.5	2.5	4.0	4.0	4.0	4.0
Maximum pressure	[bar]	8.0	8.0	6.5	6.5	6.5	6.5
Nominal pressure	[bar]	6.0	6.0	6.0	6.0	6.0	6.0
Closing time	[s]	0.15	0.15	0.12	0.12	0.25	0.25
Opening time	[s]	0.15	0.15	0.25	0.25	0.12	0.12
Max. permitted finger length	[mm]	220.0	210.0	210.0	200.0	210.0	200.0
Max. permitted weight per finger	[kg]	3.5	3.5	3.5	3.5	3.5	3.5
IP rating		40	40	40	40	40	40
Min. ambient temperature	[°C]	-10.0	-10.0	-10.0	-10.0	-10.0	-10.0
Température ambiante max.	[°C]	90.0	90.0	90.0	90.0	90.0	90.0
Repeat accuracy	[mm]	0.01	0.01	0.01	0.01	0.01	0.01

### OPTIONS and their characteristics

Dust-protection version	ID	37371104	37371154	37371404	37371454	37371464	37371474
IP rating		64	64	64	64	64	64
Weight	[kg]	3.0	3.0	3.7	3.7	3.7	3.7
Anti-corrosion version	ID	38371104	38371154	38371404	38371454	38371464	38371474
High-temperature version	ID	39371104	39371154	39371404	39371454	39371464	39371474
Min. ambient temperature	[°C]	-10.0	-10.0	-10.0	-10.0	-10.0	-10.0
Température ambiante max.	[°C]	130.0	130.0	130.0	130.0	130.0	130.0
KVZ for increased grip force	ID	0372104	0372154	0372404		0372464	
Description		PGN-plus 160-1-KVZ	PGN-plus 160-2-KVZ	PGN-plus 160-1-AS-KVZ		PGN-plus 160-1-IS-KVZ	
Closing force	[N]	2950.0	5760.0	3520.0			
Opening force	[N]	3185.0	6230.0			3755.0	
Weight	[kg]	3.4	3.4	4.4		4.4	
Maximum pressure	[bar]	6.0	6.0	6.0		6.0	
Max. permitted finger length	[mm]	160.0	125.0	125.0		125.0	

### Main views

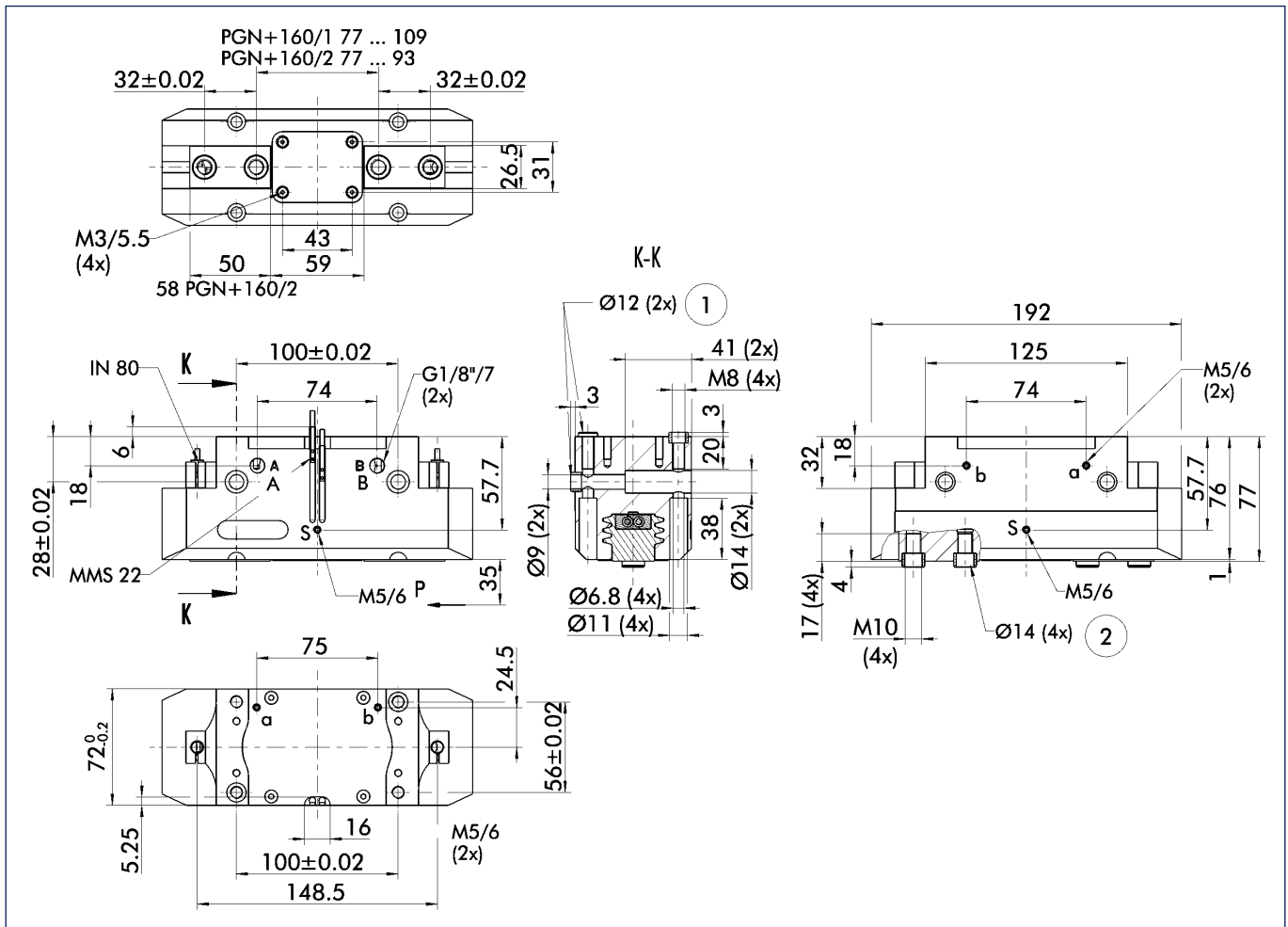

The drawing shows the gripper in the basic version with closed jaws, the dimensions do not include the options described below.

① The SDV-P pressure maintenance valve can also be used (see „Accessories“ catalog section) for I.D. or O.D. gripping as an alternative or in addition to the spring-loaded, mechanical gripping force safety device.

- A,a Main/direct connection, gripper opening
- B,b Main/direct connection, gripper closing
- S,s Air purge or ventilation hole
- ① Gripper connection
- ② Finger connection

### Hose-free direct connection

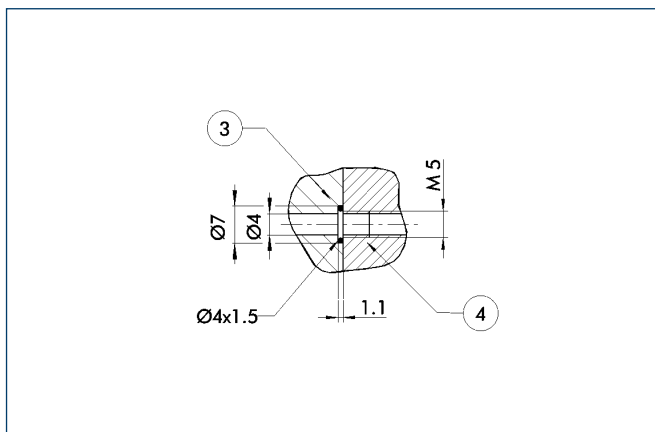

③ Adapter

④ Gripper

The direct connection is used for supplying compressed air to the gripper without hoses. Instead, the pressure medium is fed through bore-holes in the mounting plate.

### AS/IS gripping force safety device

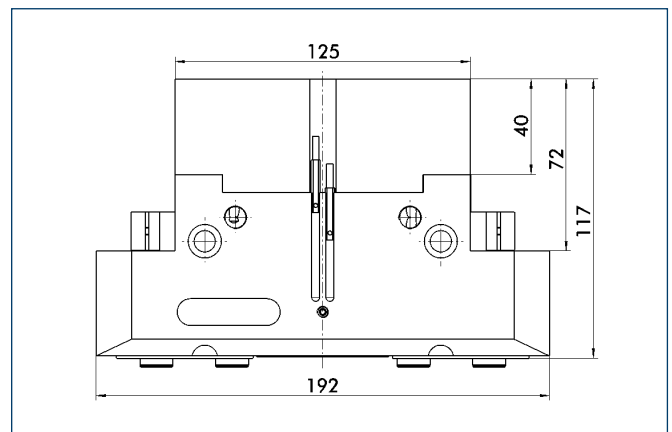

The mechanical gripping force safety device ensures a minimum gripping force even if there is a drop in pressure. This acts as closing force in the AS version, and as opening force in the IS version. In addition, the gripping force safety device can also be employed as a gripping force booster or for single-acting gripping.

# PGN-plus 160

Pneumatic · 2-Finger Parallel Gripper · Universal Gripper

## Version with dust cover

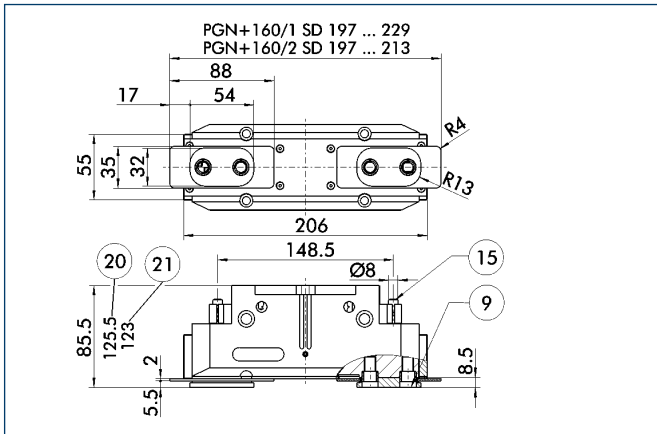

- ⑨ For screw connection diagram, see basic version
- ⑮ Sealing bolt
- ⑳ With AS / IS version
- ㉑ For KVZ version

The „dust-protection“ option increases the degree of protection against penetrating substances. The screw connection diagram shifts by the height of the intermediate jaw. The finger length is still measured from the upper edge of the gripper housing.

## KVZ for increased grip force

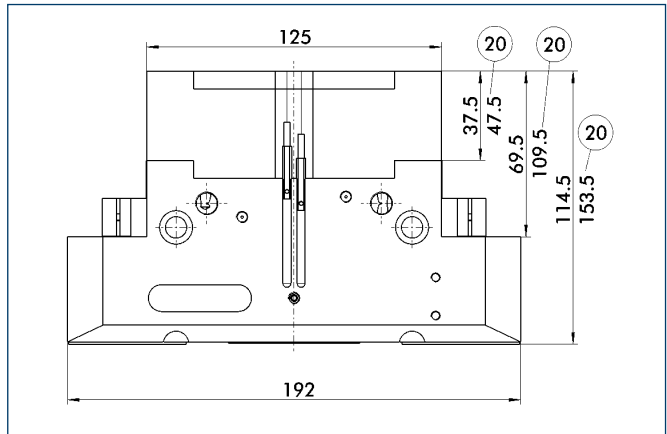

- ㉑ With AS / IS version

The KVZ cylinder increases the gripping forces during opening and closing. A second, in series-connected piston also increases the force on the wedge hook. The full gripping force shown in the data table is sometimes only reached after a few hundred gripping cycles. Please consider that grippers which are equipped with a gripping force safety device (AS / IS) are higher

## HUE protective cover

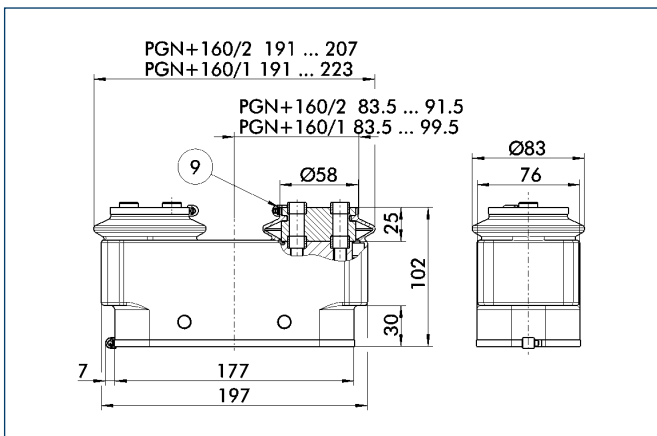

- ⑨ For screw connection diagram, see basic version

The HUE protective cover completely protects the gripper against external influences up to IP65 if an additional sealing of the cover bottom is provided as part of the application. The mounting diagram shifts by the height of the intermediate jaw.

Description	ID
HUE PGN-plus 160	0371484

## Finger blanks

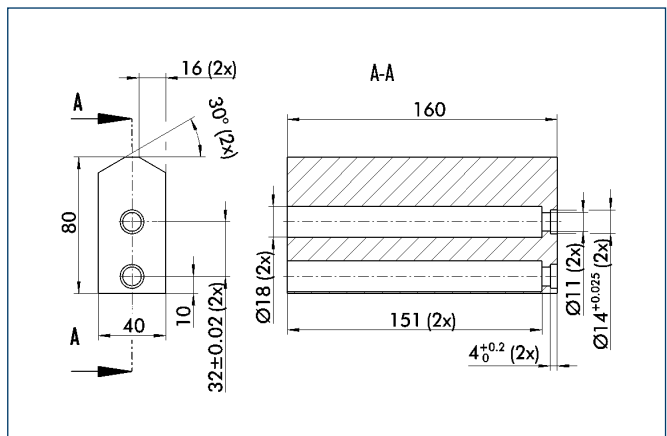

Finger blanks for customized subsequent machining, incl. screw connection diagram

Description	Material	Scope of delivery	ID
ABR-plus 160	Aluminum	1	0300014
SBR-plus 160	16 MnCr 5	1	0300024



You can find more detailed information and individual parts of the above-mentioned accessories in the „Accessories“ catalog section.



### Sensor system

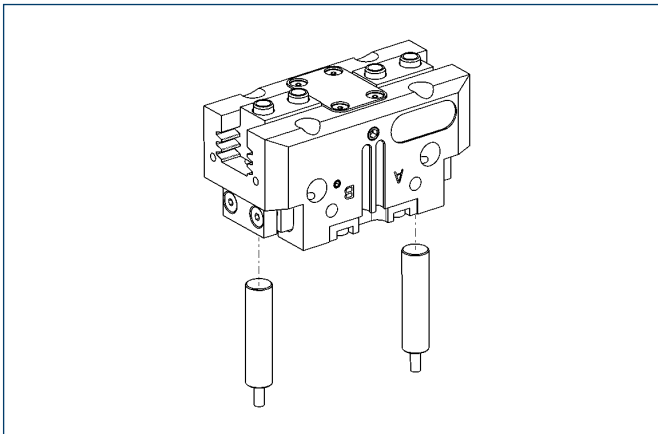

#### End position monitoring:

##### Inductive proximity switches, for direct mounting

Description	ID	Recommended product
IN 80-S-M12	0301578	
IN 80-S-M8	0301478	•
INK 80-S	0301550	

① Two sensors (NO contacts) are required for each gripper, plus extension cables as an option.

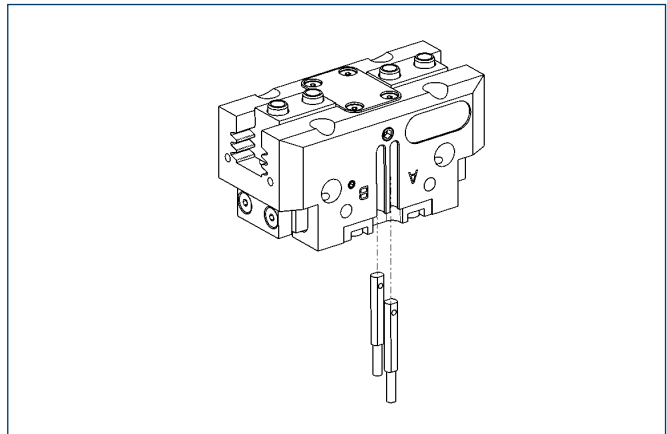

#### End position monitoring:

##### Electronic magnetic switches, for mounting in C-slot

Description	ID	Recommended product
MMS 22-S-M5-NPN	0301439	
MMS 22-S-M5-NPN-SA	0301449	
MMS 22-S-M5-PNP	0301438	
MMS 22-S-M5-PNP-SA	0301448	
MMS 22-S-M8-NPN	0301433	
MMS 22-S-M8-NPN-SA	0301443	
MMS 22-S-M8-PNP	0301432	•
MMS 22-S-M8-PNP-SA	0301442	
MMSK 22-S-NPN	0301435	
MMSK 22-S-NPN-SA	0301445	
MMSK 22-S-PNP	0301434	
MMSK 22-S-PNP-SA	0301444	

① Two sensors (NO contacts) are required for each gripper, plus extension cables as an option.

#### Extension cables for proximity switches/magnetic switches

Description	ID
KA BG05-L 3P-0300	0301652
KA BG08-L 3P-0300-PNP	0301622
KA BW05-L 3P-0300	0301650
KA BW08-L 3P-0300-NPN	0301602
KA BW08-L 3P-0300-PNP	0301594
KA BW08-L 3P-0500-NPN	9641116
KA BW08-L 3P-0500-PNP	0301502
KA BW12-L 3P-0300-PNP	0301503
KA BW12-L 3P-0500-PNP	0301507
KV BW08-SG08 3P-0030-PNP	0301495
KV BW08-SG08 3P-0100-PNP	0301496
KV BW08-SG08 3P-0200-PNP	0301497
KV BW12-SG12 3P-0030-PNP	0301595
KV BW12-SG12 3P-0100-PNP	0301596
KV BW12-SG12 3P-0200-PNP	0301597

① Please note the minimum permitted bending radii for the sensor cables, which are generally 35 mm.



You can find more detailed information and individual parts of the above-mentioned accessories in the „Accessories“ catalog section.



### Sensor system

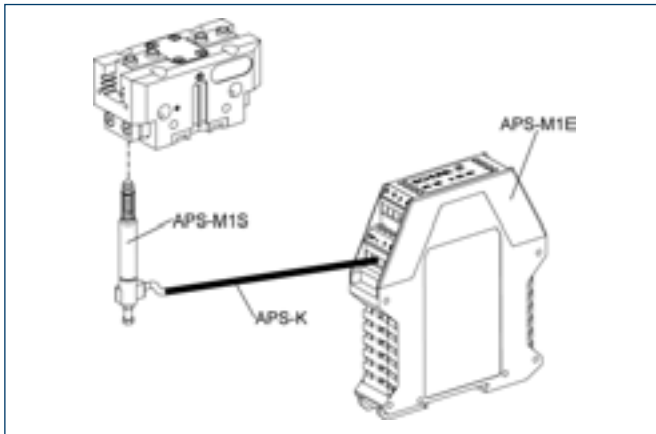

Measuring system:

APS Analog position sensor

Description	ID
APS-K0200	0302066
APS-K0700	0302068
APS-M1E	0302064
APS-M1S	0302062
AS-APS-M1-160/1 und 240/2	0302083
AS-APS-M1-160/2	0302084

- ① When using an APS system, a mounting kit (AS-APS, incl. 3 m cable), an APS sensor (APS-M1S) and electronics (APS-M1E) are required for each gripper. An extension cable (APS-K) can be connected between the sensor and the electronics as an option. The max. cable length between the sensor and the electronics is 10 m, between the electronics and their control unit (PLC) it is max. 1 m.

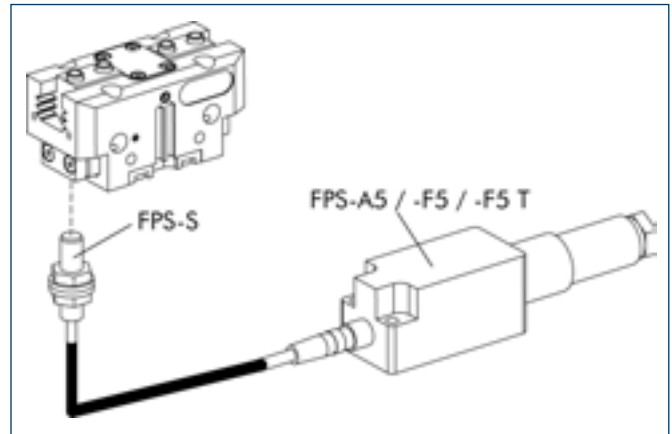

Measuring system:

FPS Flexible position sensor

Description	ID
AS-PGN/PZN-plus 160/1	0301638
AS-PGN/PZN-plus 160/2	0301639
FPS-F5	0301805
FPS-F5 T	0301807
FPS-S M8	0301704

- ① When using an FPS system, an FPS sensor (FPS-S) and an control unit (FPS-F5 / F5 T or A5) are required for each gripper as well as a mounting kit (AS), if listed. Cable extensions (KV) are available as options in the „Accessories“ catalog section.

### Maximum permitted finger offset

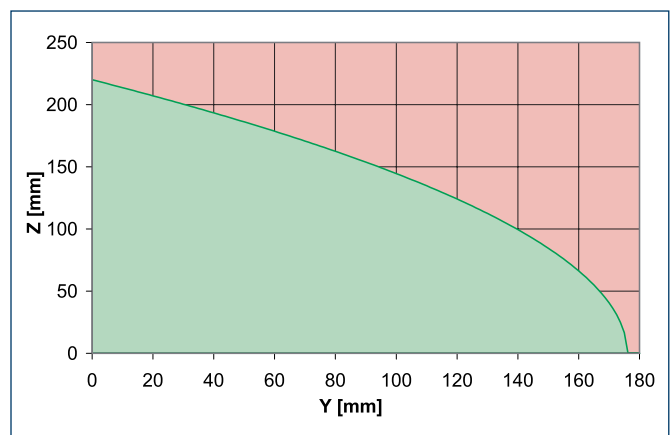
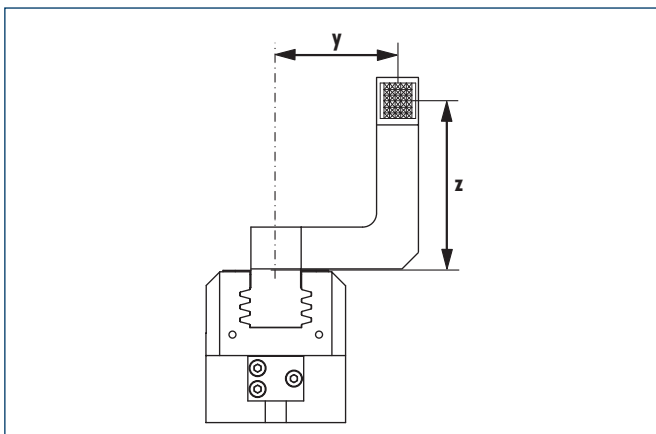

- Permitted range  
■ Non-permissible range

The curve applies to the basic version (stroke -1). For other versions, the curve will be parallel but offset in line with the max. permitted finger length.



You can find more detailed information and individual parts of the above-mentioned accessories in the „Accessories“ catalog section.

# PGN-plus 200

Pneumatic · 2-Finger Parallel Gripper · Universal Gripper



## Gripping force, I.D. gripping

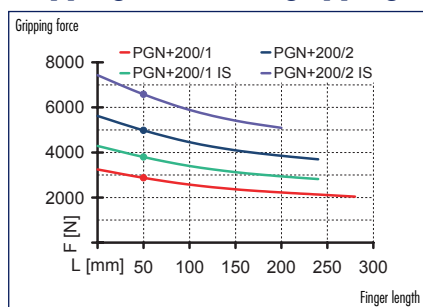

## Gripping force, O.D. gripping

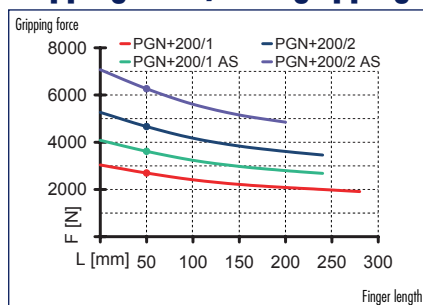

## Finger load

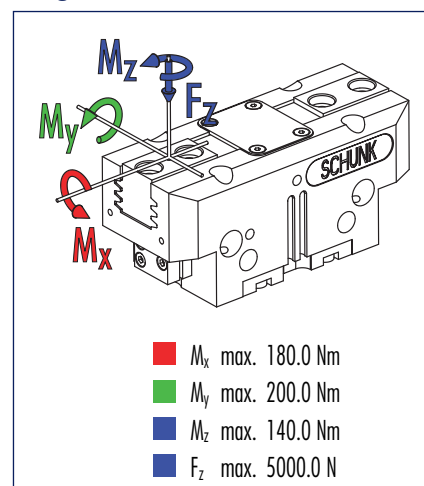

① Moments and forces apply per base jaw and may occur simultaneously.  $M_y$  may arise in addition to the moment generated by the gripping force itself. If the max. permitted finger weight is exceeded, it is imperative to throttle the air pressure so that the jaw movement occurs without any hitting or bouncing. Service life may reduce.

## Technical data

Description		PGN-plus 200-1	PGN-plus 200-2	PGN-plus 200-1-AS	PGN-plus 200-2-AS	PGN-plus 200-1-IS	PGN-plus 200-2-IS
	ID	0371105	0371155	0371405	0371455	0371465	0371475
Stroke per jaw	[mm]	25.0	14.0	25.0	14.0	25.0	14.0
Closing force	[N]	2700.0	4650.0	3610.0	6250.0		
Opening force	[N]	2870.0	4980.0			3780.0	6580.0
Min. spring force	[N]			910.0	1600.0	910.0	1600.0
Weight	[kg]	5.4	5.4	7.5	7.5	7.5	7.5
Recommended workpiece weight	[kg]	13.5	23.5	13.5	23.5	13.5	23.5
Air consumption per double stroke	[cm <sup>3</sup> ]	390.0	390.0	390.0	390.0	390.0	390.0
Minimum pressure	[bar]	2.5	2.5	4.0	4.0	4.0	4.0
Maximum pressure	[bar]	8.0	8.0	6.5	6.5	6.5	6.5
Nominal pressure	[bar]	6.0	6.0	6.0	6.0	6.0	6.0
Closing time	[s]	0.35	0.35	0.3	0.3	0.6	0.6
Opening time	[s]	0.35	0.35	0.6	0.6	0.3	0.3
Max. permitted finger length	[mm]	280.0	240.0	240.0	200.0	240.0	200.0
Max. permitted weight per finger	[kg]	6.5	6.5	6.5	6.5	6.5	6.5
IP rating		40	40	40	40	40	40
Min. ambient temperature	[°C]	-10.0	-10.0	-10.0	-10.0	-10.0	-10.0
Température ambiante max.	[°C]	90.0	90.0	90.0	90.0	90.0	90.0
Repeat accuracy	[mm]	0.02	0.02	0.02	0.02	0.02	0.02

### OPTIONS and their characteristics

Dust-protection version	ID	37371105	37371155	37371405	37371455	37371465	37371475
IP rating		64	64	64	64	64	64
Weight	[kg]	6.0	6.0	8.1	8.1	8.1	8.1
Anti-corrosion version	ID	38371105	38371155	38371405	38371455	38371465	38371475
High-temperature version	ID	39371105	39371155	39371405	39371455	39371465	39371475
Min. ambient temperature	[°C]	-10.0	-10.0	-10.0	-10.0	-10.0	-10.0
Température ambiante max.	[°C]	130.0	130.0	130.0	130.0	130.0	130.0
KVZ for increased grip force	ID	0372105	0372155	0372405		0372465	
Description		PGN-plus 200-1-KVZ	PGN-plus 200-2-KVZ	PGN-plus 200-1-AS-KVZ		PGN-plus 200-1-IS-KVZ	
Closing force	[N]	4860.0	8370.0	5770.0			
Opening force	[N]	5165.0	8965.0			6075.0	
Weight	[kg]	6.7	6.7	9.0		9.0	
Maximum pressure	[bar]	6.0	6.0	6.0		6.0	
Max. permitted finger length	[mm]	200.0	160.0	160.0		160.0	

### Main views

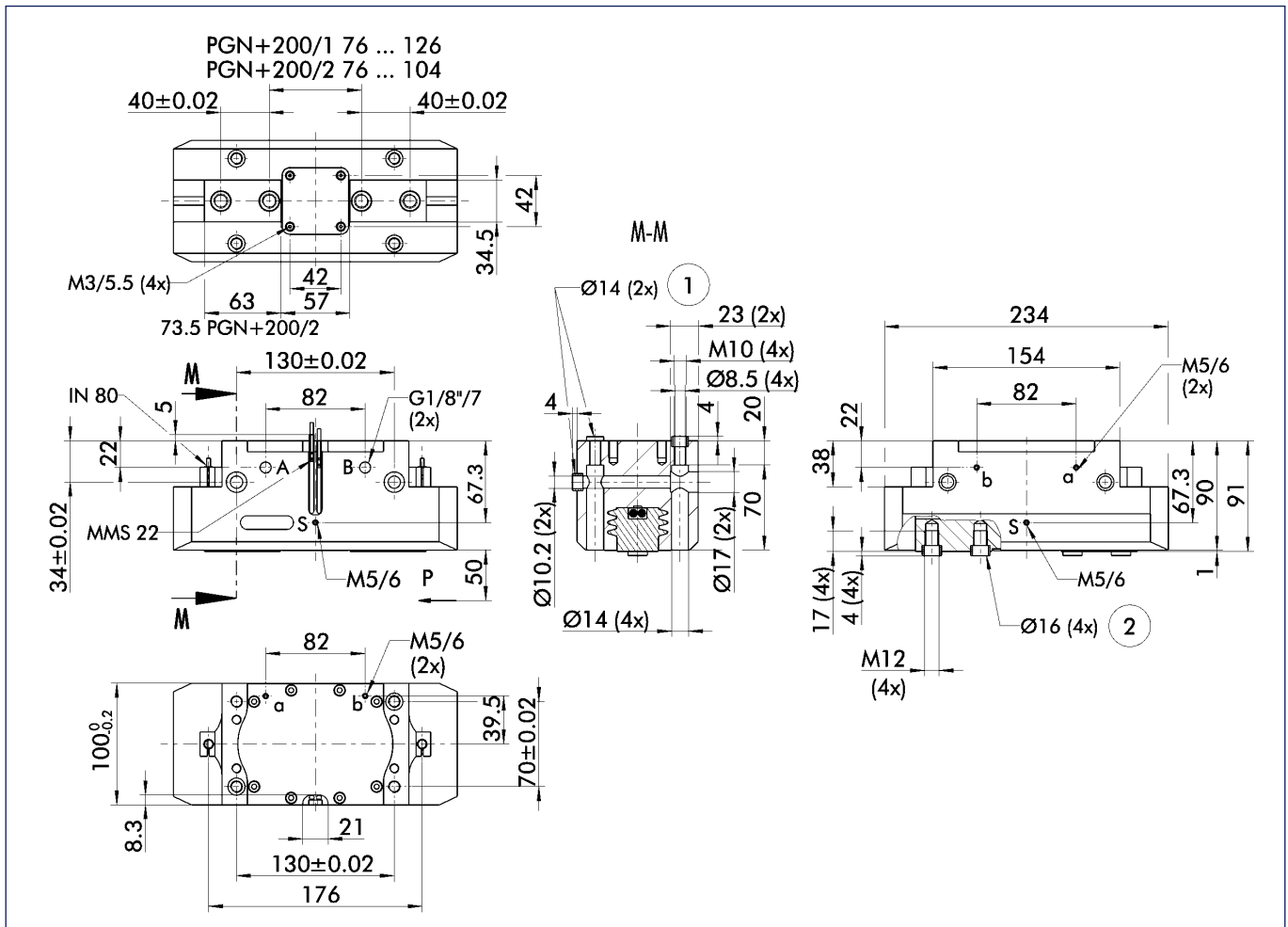

The drawing shows the gripper in the basic version with closed jaws, the dimensions do not include the options described below.

① The SDV-P pressure maintenance valve can also be used (see „Accessories“ catalog section) for I.D. or O.D. gripping as an alternative or in addition to the spring-loaded, mechanical gripping force safety device.

- A,a Main/direct connection, gripper opening
- B,b Main/direct connection, gripper closing
- S,s Air purge or ventilation hole
- ① Gripper connection
- ② Finger connection

### Hose-free direct connection

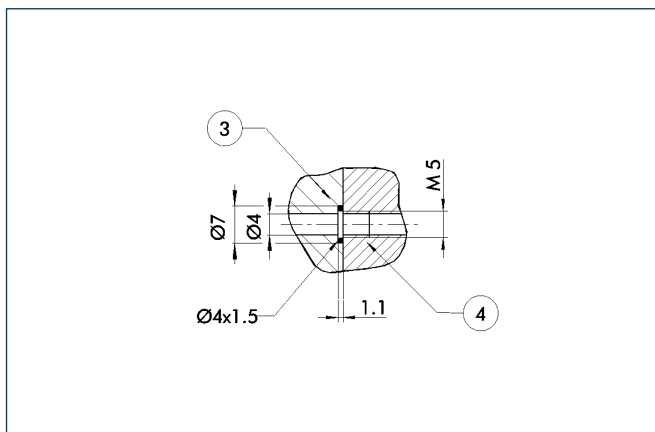

- ③ Adapter
- ④ Gripper

The direct connection is used for supplying compressed air to the gripper without hoses. Instead, the pressure medium is fed through bore-holes in the mounting plate.

### AS/IS gripping force safety device

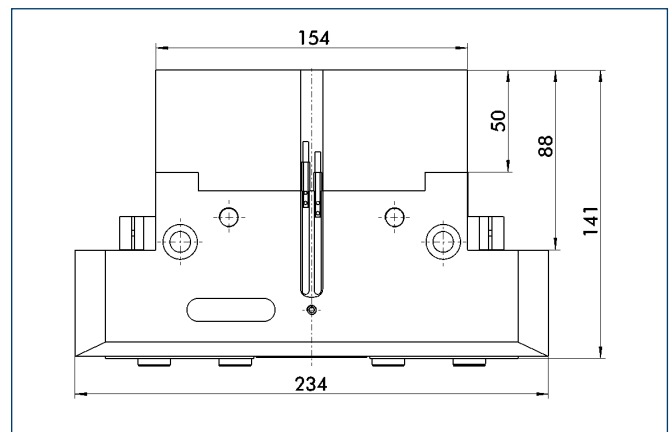

The mechanical gripping force safety device ensures a minimum gripping force even if there is a drop in pressure. This acts as closing force in the AS version, and as opening force in the IS version. In addition, the gripping force safety device can also be employed as a gripping force booster or for single-acting gripping.

# PGN-plus 200

## Pneumatic · 2-Finger Parallel Gripper · Universal Gripper

### Version with dust cover

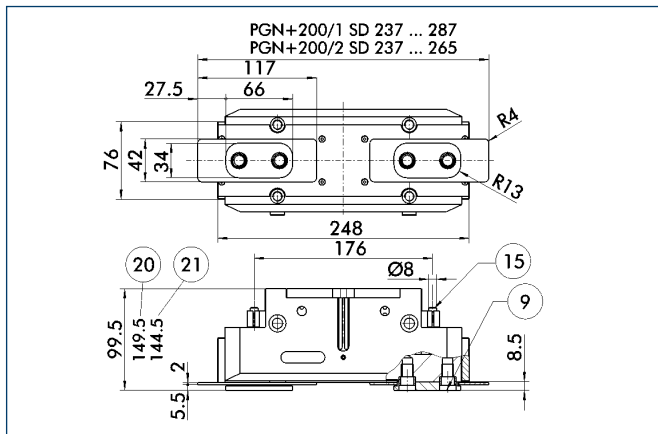

- ⑨ For screw connection diagram, see basic version
- ⑮ Sealing bolt
- ⑳ With AS / IS version
- ㉑ For KVZ version

The „dust-protection“ option increases the degree of protection against penetrating substances. The screw connection diagram shifts by the height of the intermediate jaw. The finger length is still measured from the upper edge of the gripper housing.

### Finger blanks

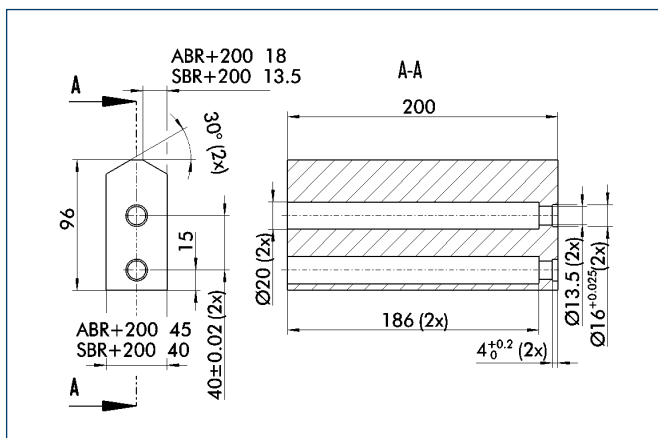

Finger blanks for customized subsequent machining, incl. screw connection diagram

Description	Material	Scope of delivery	ID
ABR-plus 200	Aluminum	1	0300015
SBR-plus 200	16 MnCr 5	1	0300025

### KVZ for increased grip force

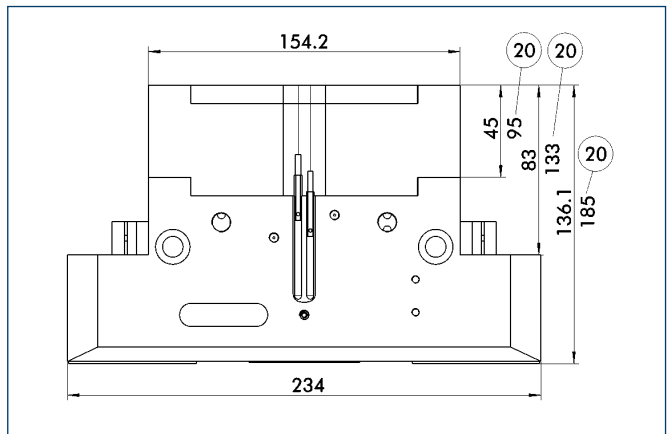

- ㉒ With AS / IS version

The KVZ cylinder increases the gripping forces during opening and closing. A second, in series-connected piston also increases the force on the wedge hook. The full gripping force shown in the data table is sometimes only reached after a few hundred gripping cycles. Please consider that grippers which are equipped with a gripping force safety device (AS / IS) are higher.

### FMS force measuring jaws

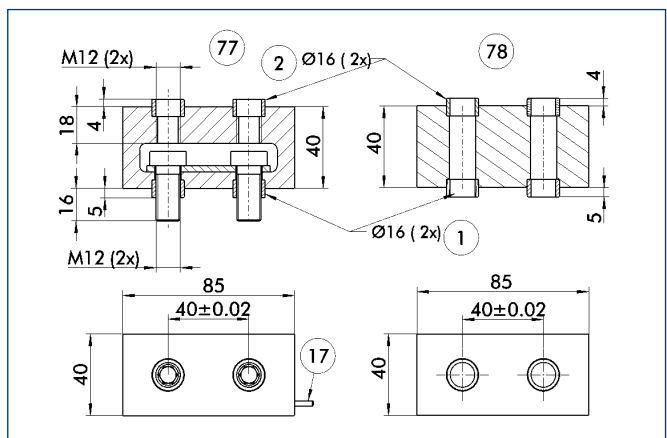

- ① Gripper connection
- ② Finger connection
- ⑰ Cable outlet
- ⑱ Fine serration
- ⑲ Air connection

Force measuring jaws measure gripping forces, but can also determine workpiece weights or dimensional deviations. There are active and passive intermediate jaws (FMS-ZBA or FMS-ZBP). At least one active force measuring jaw is required per gripper, the rest can be passive. For each active jaw, an FMS-A1 control unit and an FMS-A connection cable are required.

Description	ID
FMS-A2	0301811
FMS-AK0200	0301820
FMS-AK0500	0301821
FMS-AK1000	0301822
FMS-AK2000	0301823
FMS-ZBA 200	0301842
FMS-ZBP 200	0301843



You can find more detailed information and individual parts of the above-mentioned accessories in the „Accessories“ catalog section.

### Sensor system

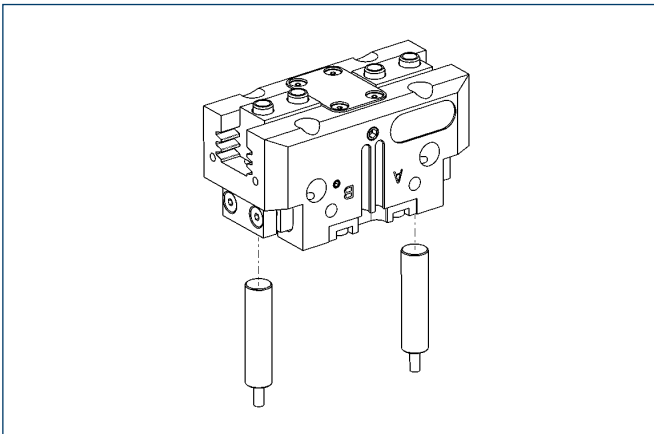

End position monitoring:  
Inductive proximity switches, for direct mounting

Description	ID	Recommended product
IN 80-S-M12	0301578	
IN 80-S-M8	0301478	•
INK 80-S	0301550	

① Two sensors (NO contacts) are required for each gripper, plus extension cables as an option.

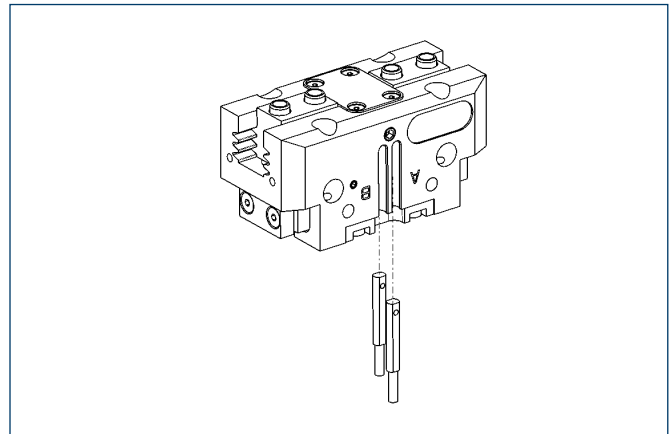

End position monitoring:  
Electronic magnetic switches, for mounting in C-slot

Description	ID	Recommended product
MMS 22-S-M5-NPN	0301439	
MMS 22-S-M5-NPN-SA	0301449	
MMS 22-S-M5-PNP	0301438	
MMS 22-S-M5-PNP-SA	0301448	
MMS 22-S-M8-NPN	0301433	
MMS 22-S-M8-NPN-SA	0301443	
MMS 22-S-M8-PNP	0301432	•
MMS 22-S-M8-PNP-SA	0301442	
MMSK 22-S-NPN	0301435	
MMSK 22-S-NPN-SA	0301445	
MMSK 22-S-PNP	0301434	
MMSK 22-S-PNP-SA	0301444	

① Two sensors (NO contacts) are required for each gripper, plus extension cables as an option.

### Extension cables for proximity switches/magnetic switches

Description	ID
KA BG05-L 3P-0300	0301652
KA BG08-L 3P-0300-PNP	0301622
KA BW05-L 3P-0300	0301650
KA BW08-L 3P-0300-NPN	0301602
KA BW08-L 3P-0300-PNP	0301594
KA BW08-L 3P-0500-NPN	9641116
KA BW08-L 3P-0500-PNP	0301502
KA BW12-L 3P-0300-PNP	0301503
KA BW12-L 3P-0500-PNP	0301507
KV BW08-SG08 3P-0030-PNP	0301495
KV BW08-SG08 3P-0100-PNP	0301496
KV BW08-SG08 3P-0200-PNP	0301497
KV BW12-SG12 3P-0030-PNP	0301595
KV BW12-SG12 3P-0100-PNP	0301596
KV BW12-SG12 3P-0200-PNP	0301597

① Please note the minimum permitted bending radii for the sensor cables, which are generally 35 mm.



You can find more detailed information and individual parts of the above-mentioned accessories in the „Accessories“ catalog section.

### Sensor system

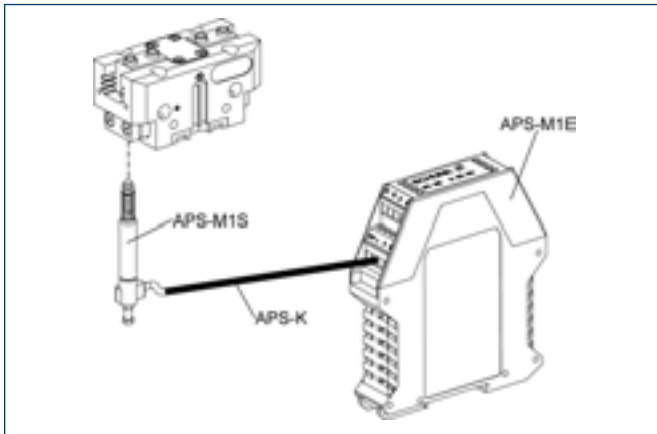

Measuring system:

APS Analog position sensor

Description	ID
APS-K0200	0302066
APS-K0700	0302068
APS-M1E	0302064
APS-M1S	0302062
AS-APS-M1-200/1 und 380/2	0302085
AS-APS-M1-200/2	0302086

- ① When using an APS system, a mounting kit (AS-APS, incl. 3 m cable), an APS sensor (APS-M1S) and electronics (APS-M1E) are required for each gripper. An extension cable (APS-K) can be connected between the sensor and the electronics as an option. The max. cable length between the sensor and the electronics is 10 m, between the electronics and their control unit (PLC) it is max. 1 m.

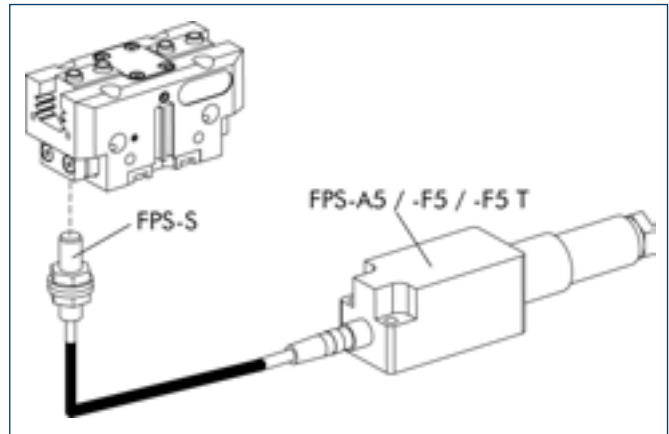

Measuring system:

FPS Flexible position sensor

Description	ID
AS-PGN/PZN-plus 200/1	0301640
AS-PGN/PZN-plus 200/2	0301641
FPS-F5	0301805
FPS-F5 T	0301807
FPS-S M8	0301704

- ① When using an FPS system, an FPS sensor (FPS-S) and an control unit (FPS-F5 / F5 T or A5) are required for each gripper as well as a mounting kit (AS), if listed. Cable extensions (KV) are available as options in the „Accessories“ catalog section.

### Maximum permitted finger offset

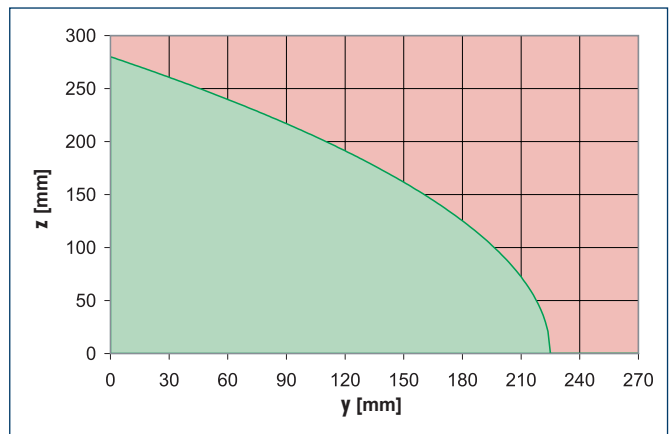
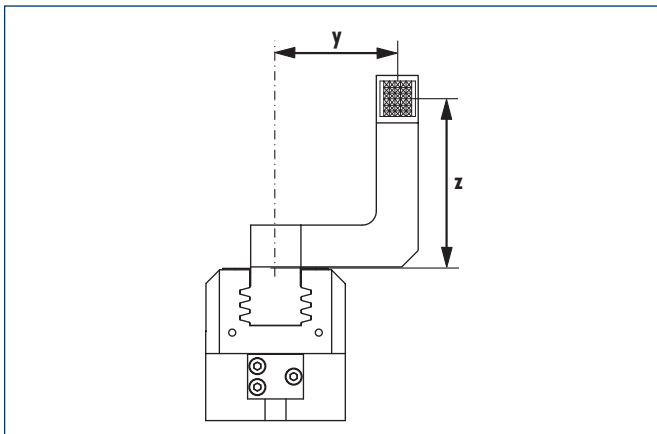

- Permitted range
- Non-permissible range

The curve applies to the basic version (stroke -1). For other versions, the curve will be parallel but offset in line with the max. permitted finger length.



You can find more detailed information and individual parts of the above-mentioned accessories in the „Accessories“ catalog section.

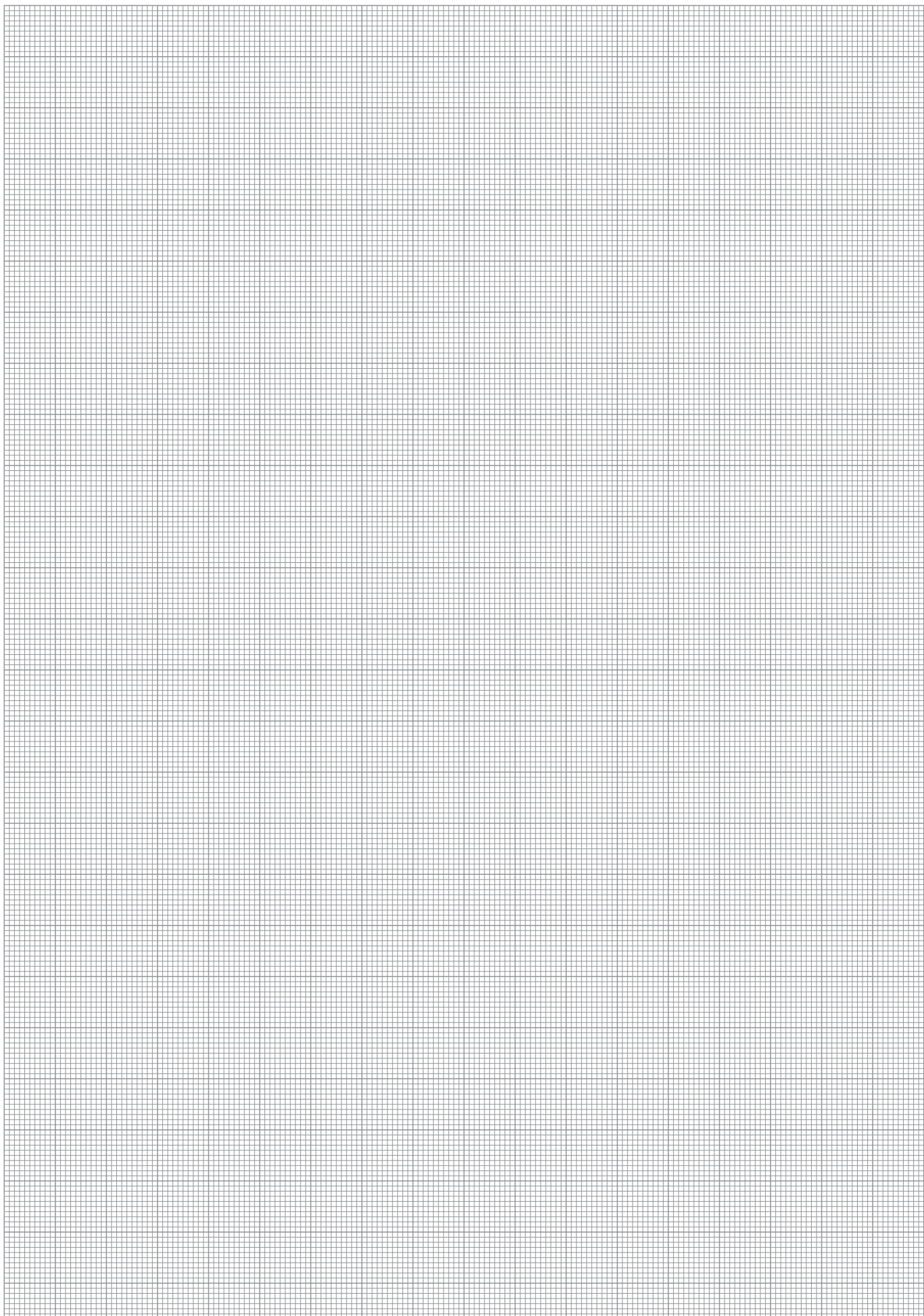



# PGN-plus 240

Pneumatic · 2-Finger Parallel Gripper · **Universal Gripper**

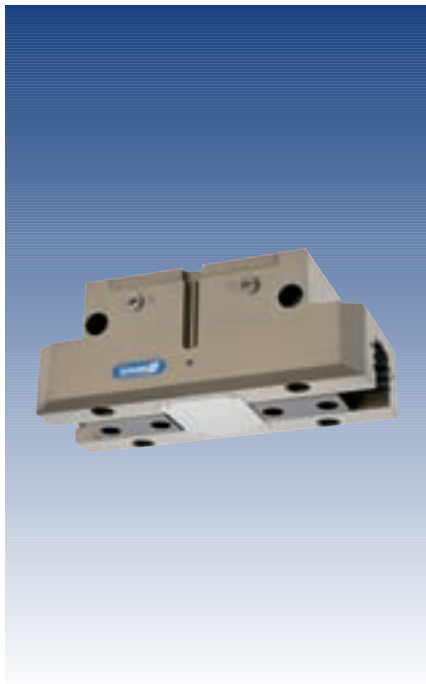

## Gripping force, I.D. gripping

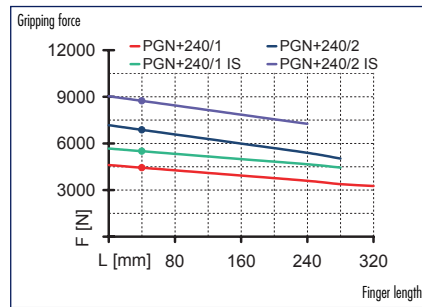

## Gripping force, O.D. gripping

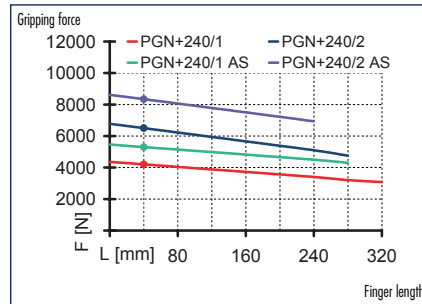

## Finger load

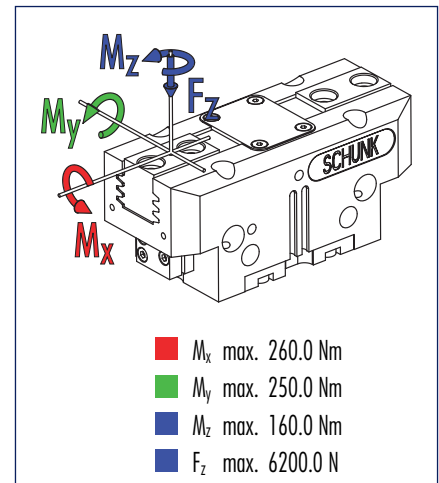

① Moments and forces apply per base jaw and may occur simultaneously.  $M_y$  may arise in addition to the moment generated by the gripping force itself. If the max. permitted finger weight is exceeded, it is imperative to throttle the air pressure so that the jaw movement occurs without any hitting or bouncing. Service life may reduce.

## Technical data

Description		PGN-plus 240-1	PGN-plus 240-2	PGN-plus 240-1-AS	PGN-plus 240-2-AS	PGN-plus 240-1-IS	PGN-plus 240-2-IS
	ID	0371108	0371158	0371408	0371458	0371468	0371478
Stroke per jaw	[mm]	30.0	17.0	30.0	17.0	30.0	17.0
Closing force	[N]	4200.0	6500.0	5300.0	8340.0		
Opening force	[N]	4440.0	6870.0			5540.0	8710.0
Min. spring force	[N]			1100.0	1840.0	1100.0	1840.0
Weight	[kg]	8.5	8.5	12.0	12.0	12.0	12.0
Recommended workpiece weight	[kg]	20.0	34.5	20.0	34.5	20.0	34.5
Air consumption per double stroke	[cm <sup>3</sup> ]	646.0	646.0	646.0	646.0	646.0	646.0
Minimum pressure	[bar]	2.5	2.5	4.0	4.0	4.0	4.0
Maximum pressure	[bar]	8.0	8.0	6.5	6.5	6.5	6.5
Nominal pressure	[bar]	6.0	6.0	6.0	6.0	6.0	6.0
Closing time	[s]	0.45	0.45	0.35	0.35	0.65	0.65
Opening time	[s]	0.45	0.45	0.65	0.65	0.35	0.35
Max. permitted finger length	[mm]	320.0	280.0	280.0	240.0	280.0	240.0
Max. permitted weight per finger	[kg]	8.5	8.5	8.5	8.5	8.5	8.5
IP rating		40	40	40	40	40	40
Min. ambient temperature	[°C]	-10.0	-10.0	-10.0	-10.0	-10.0	-10.0
Température ambiante max.	[°C]	90.0	90.0	90.0	90.0	90.0	90.0
Repeat accuracy	[mm]	0.04	0.04	0.04	0.04	0.04	0.04

### OPTIONS and their characteristics

Dust-protection version	ID	37371108	37371158	37371408	37371458	37371468	37371478
IP rating		64	64	64	64	64	64
Weight	[kg]	11.4	11.4	14.4	14.4	14.4	14.4
Anti-corrosion version	ID	38371108	38371158	38371408	38371458	38371468	38371478
High-temperature version	ID	39371108	39371158	39371408	39371458	39371468	39371478
Min. ambient temperature	[°C]	-10.0	-10.0	-10.0	-10.0	-10.0	-10.0
Température ambiante max.	[°C]	130.0	130.0	130.0	130.0	130.0	130.0



### Main views

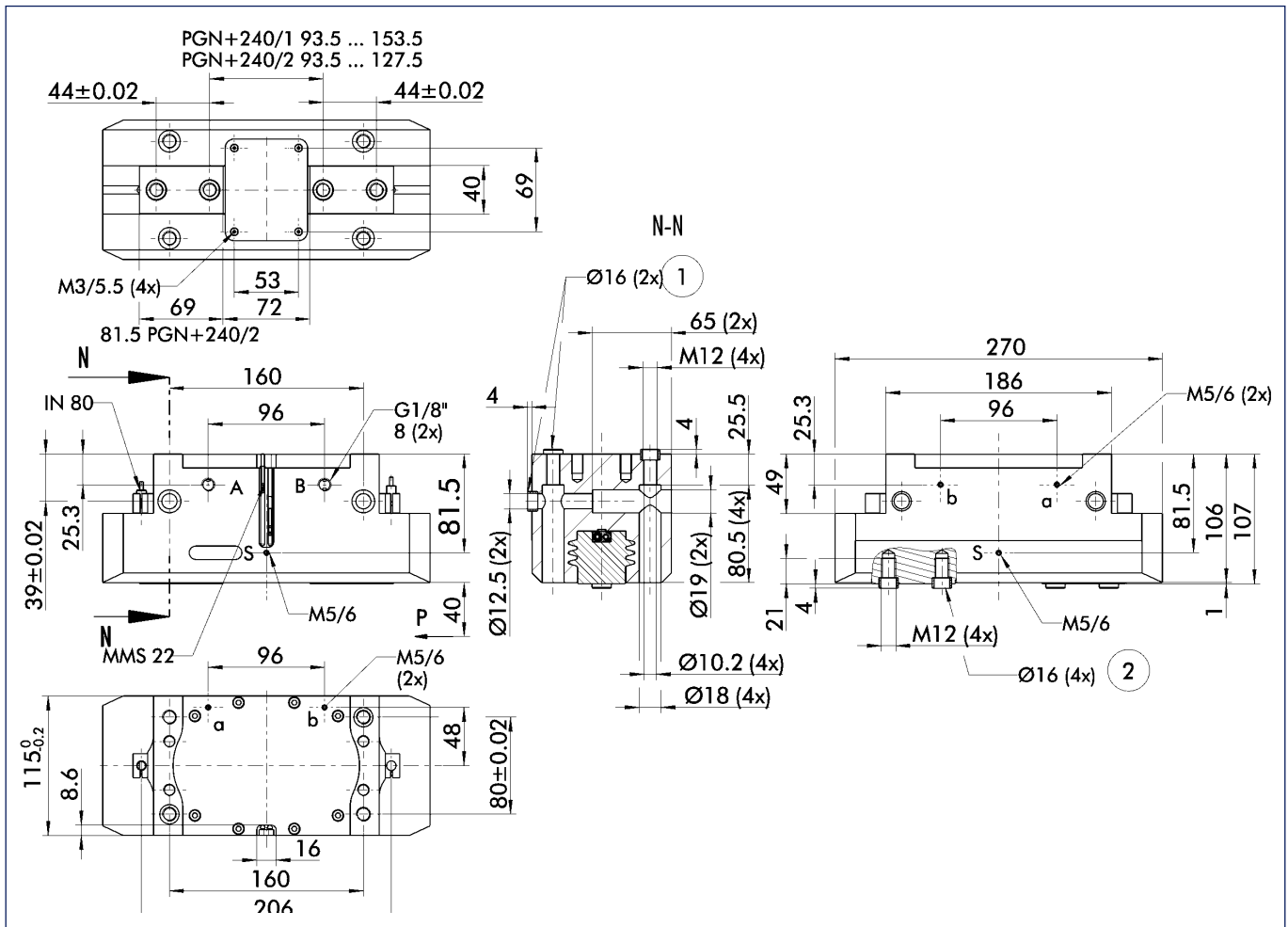

The drawing shows the gripper in the basic version with closed jaws, the dimensions do not include the options described below.

① The SDV-P pressure maintenance valve can also be used (see „Accessories“ catalog section) for I.D. or O.D. gripping as an alternative or in addition to the spring-loaded, mechanical gripping force safety device.

- A,a Main/direct connection, gripper opening
- B,b Main/direct connection, gripper closing
- S,s Air purge or ventilation hole
- ① Gripper connection
- ② Finger connection

### Hose-free direct connection

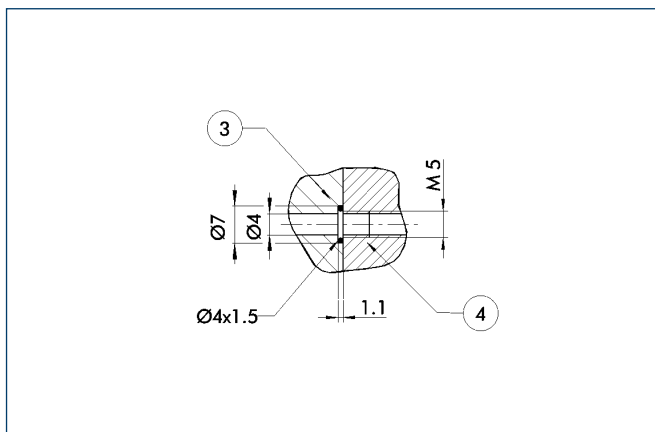

③ Adapter

④ Gripper

The direct connection is used for supplying compressed air to the gripper without hoses. Instead, the pressure medium is fed through bore-holes in the mounting plate.

### AS/IS gripping force safety device

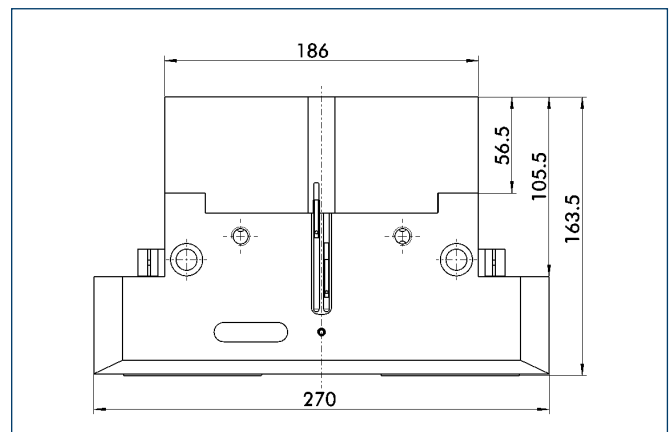

The mechanical gripping force safety device ensures a minimum gripping force even if there is a drop in pressure. This acts as closing force in the AS version, and as opening force in the IS version. In addition, the gripping force safety device can also be employed as a gripping force booster or for single-acting gripping.

# PGN-plus 240

Pneumatic · 2-Finger Parallel Gripper · Universal Gripper

## Version with dust cover

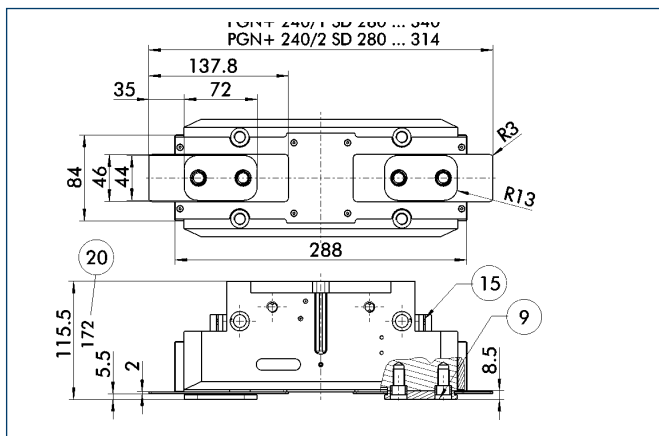

- ⑨ For screw connection diagram, see basic version
- ⑮ Sealing bolt
- ⑳ With AS / IS version

The „dust-protection“ option increases the degree of protection against penetrating substances. The screw connection diagram shifts by the height of the intermediate jaw. The finger length is still measured from the upper edge of the gripper housing.

## Finger blanks

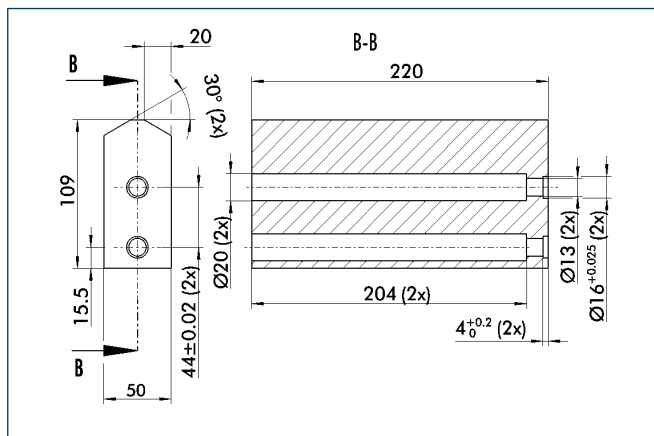

Finger blanks for customized subsequent machining, incl. screw connection diagram

Description	Material	Scope of delivery	ID
ABR-plus 240	Aluminum	1	0300017
SBR-plus 240	16 MnCr 5	1	0300027

## FMS force measuring jaws

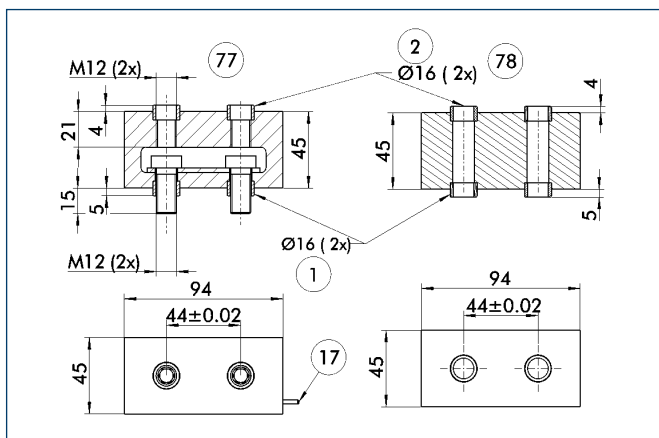

- ① Gripper connection
- ② Finger connection
- ⑰ Cable outlet
- ⑦⑦ Active intermediate jaws
- ⑦⑧ Passiv intermediate jaws

Description	ID
FMS-A2	0301811
FMS-AK0200	0301820
FMS-AK0500	0301821
FMS-AK1000	0301822
FMS-AK2000	0301823
FMS-ZBA 240	0301844
FMS-ZBP 240	0301845

You can find more detailed information and individual parts of the above-mentioned accessories in the „Accessories“ catalog section.

### Sensor system

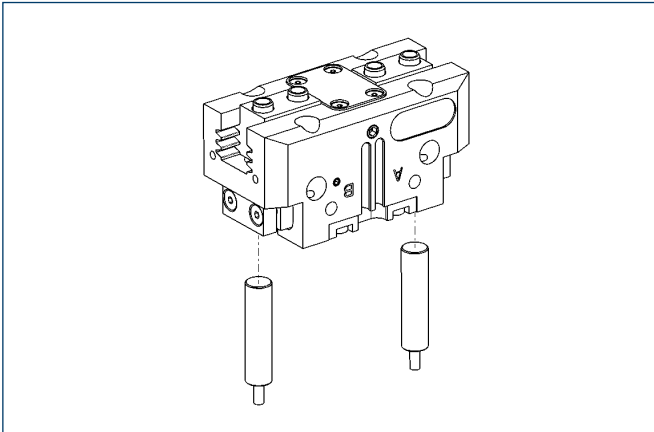

End position monitoring:  
Inductive proximity switches, for direct mounting

Description	ID	Recommended product
IN 80-S-M12	0301578	
IN 80-S-M8	0301478	•
INK 80-S	0301550	

① Two sensors (NO contacts) are required for each gripper, plus extension cables as an option.

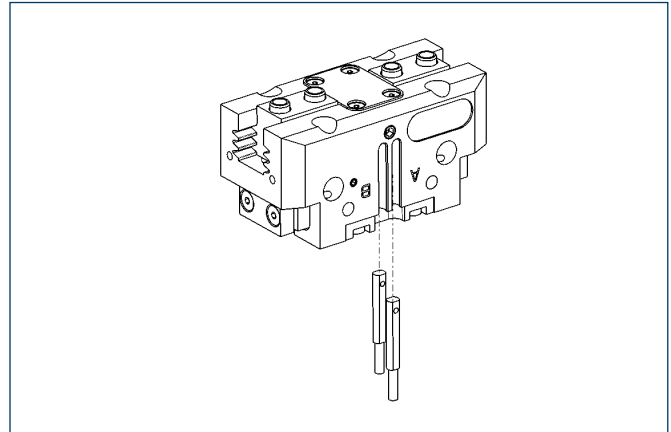

End position monitoring:  
Electronic magnetic switches, for mounting in C-slot

Description	ID	Recommended product
MMS 22-S-M5-NPN	0301439	
MMS 22-S-M5-NPN-SA	0301449	
MMS 22-S-M5-PNP	0301438	
MMS 22-S-M5-PNP-SA	0301448	
MMS 22-S-M8-NPN	0301433	
MMS 22-S-M8-NPN-SA	0301443	
MMS 22-S-M8-PNP	0301432	•
MMS 22-S-M8-PNP-SA	0301442	
MMSK 22-S-NPN	0301435	
MMSK 22-S-NPN-SA	0301445	
MMSK 22-S-PNP	0301434	
MMSK 22-S-PNP-SA	0301444	

① Two sensors (NO contacts) are required for each gripper, plus extension cables as an option.

### Extension cables for proximity switches/magnetic switches

Description	ID
KA BG05-L 3P-0300	0301652
KA BG08-L 3P-0300-PNP	0301622
KA BW05-L 3P-0300	0301650
KA BW08-L 3P-0300-NPN	0301602
KA BW08-L 3P-0300-PNP	0301594
KA BW08-L 3P-0500-NPN	9641116
KA BW08-L 3P-0500-PNP	0301502
KA BW12-L 3P-0300-PNP	0301503
KA BW12-L 3P-0500-PNP	0301507
KV BW08-SG08 3P-0030-PNP	0301495
KV BW08-SG08 3P-0100-PNP	0301496
KV BW08-SG08 3P-0200-PNP	0301497
KV BW12-SG12 3P-0030-PNP	0301595
KV BW12-SG12 3P-0100-PNP	0301596
KV BW12-SG12 3P-0200-PNP	0301597

① Please note the minimum permitted bending radii for the sensor cables, which are generally 35 mm.



You can find more detailed information and individual parts of the above-mentioned accessories in the „Accessories“ catalog section.

# PGN-plus 240

Pneumatic · 2-Finger Parallel Gripper · **Universal Gripper**

## Sensor system

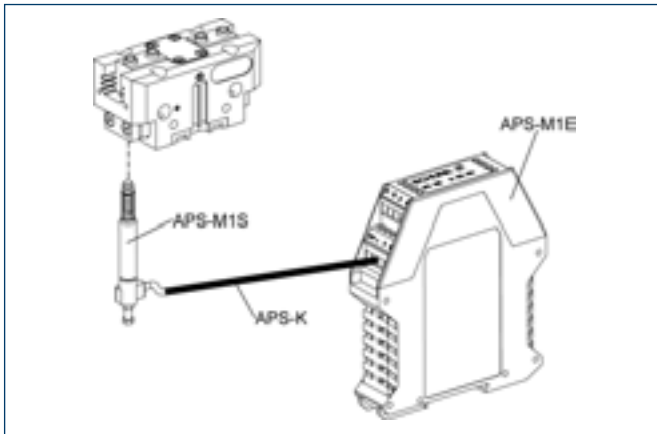

Measuring system:

APS Analog position sensor

Description	ID
APS-K0200	0302066
APS-K0700	0302068
APS-M1E	0302064
APS-M1S	0302062
AS-APS-M1-160/1 und 240/2	0302083
AS-APS-M1-240/1	0302087

- ① When using an APS system, a mounting kit (AS-APS, incl. 3 m cable), an APS sensor (APS-M1S) and electronics (APS-M1E) are required for each gripper. An extension cable (APS-K) can be connected between the sensor and the electronics as an option. The max. cable length between the sensor and the electronics is 10 m, between the electronics and their control unit (PLC) it is max. 1 m.

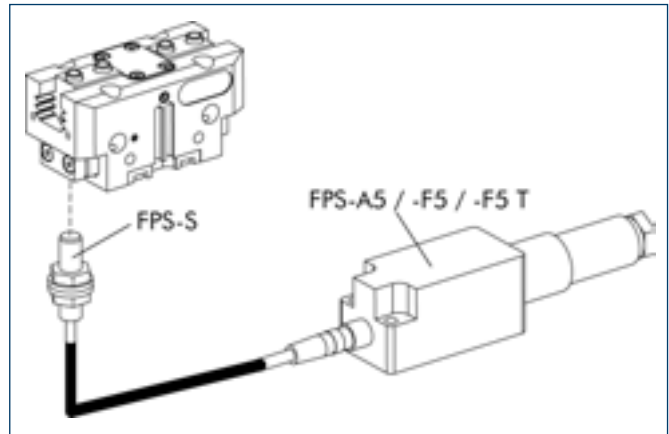

Measuring system:

FPS Flexible position sensor

Description	ID
AS-PGN/PZN-plus 240/1	0301643
AS-PGN/PZN-plus 240/2	0301644
FPS-F5	0301805
FPS-F5 T	0301807
FPS-S M8	0301704

- ① When using an FPS system, an FPS sensor (FPS-S) and an control unit (FPS-F5 / F5 T or A5) are required for each gripper as well as a mounting kit (AS), if listed. Cable extensions (KV) are available as options in the „Accessories“ catalog section.

## Maximum permitted finger offset

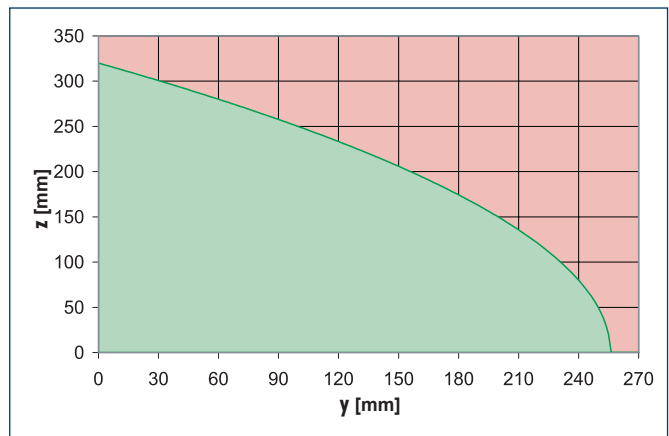
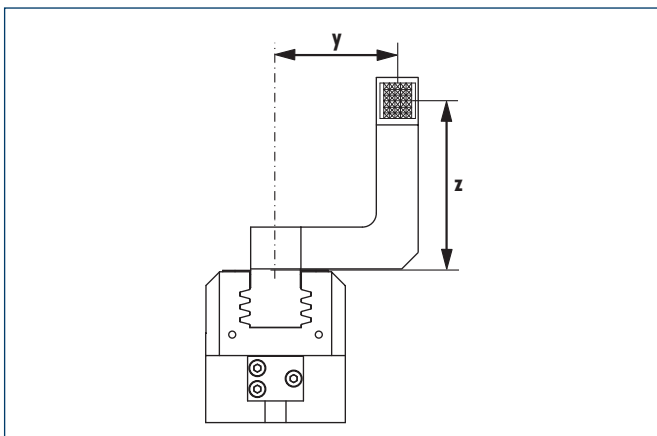

- Permitted range  
■ Non-permissible range

The curve applies to the basic version (stroke -1). For other versions, the curve will be parallel but offset in line with the max. permitted finger length.



You can find more detailed information and individual parts of the above-mentioned accessories in the „Accessories“ catalog section.

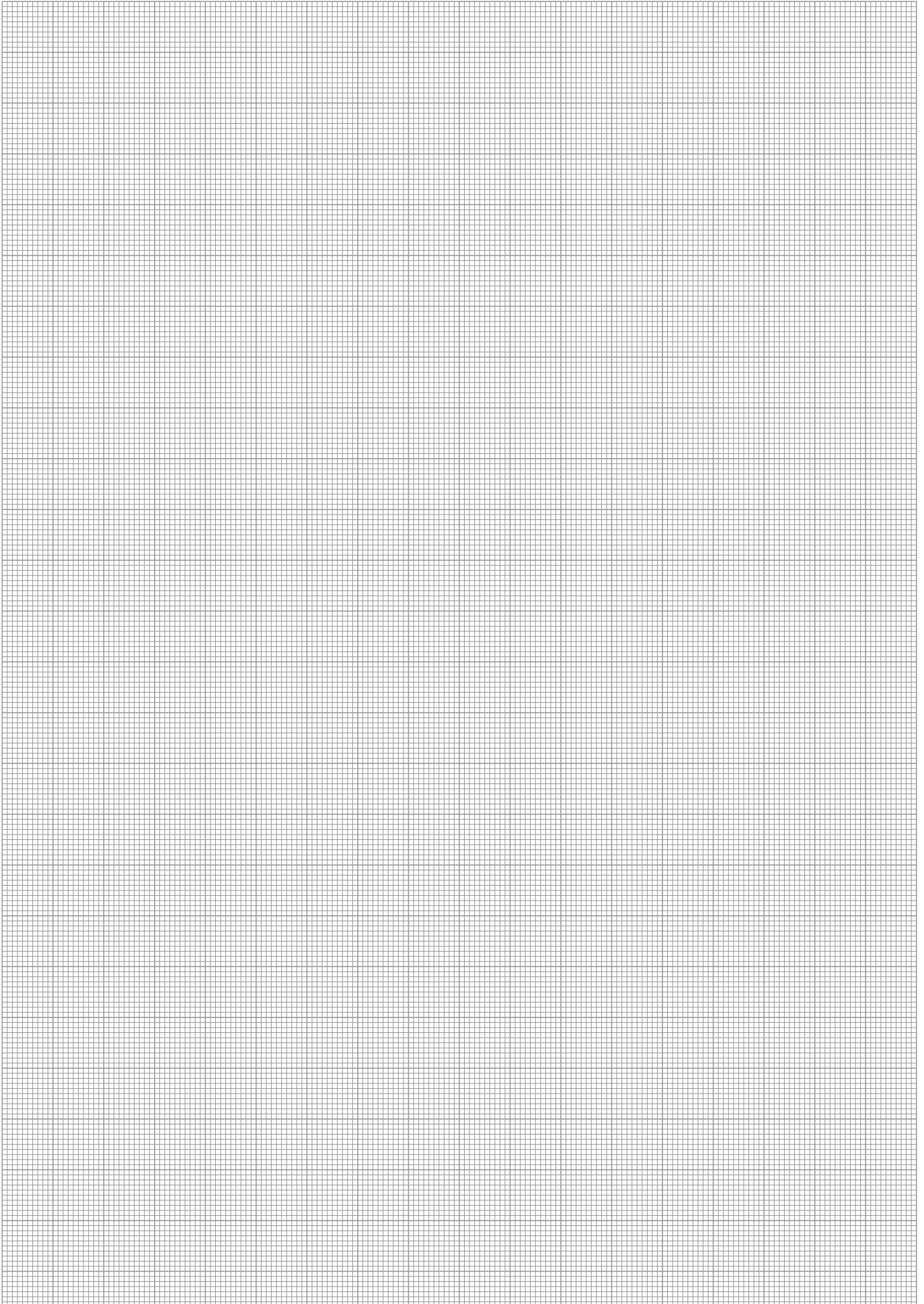

# PGN-plus 300

Pneumatic · 2-Finger Parallel Gripper · Universal Gripper



## Gripping force, I.D. gripping

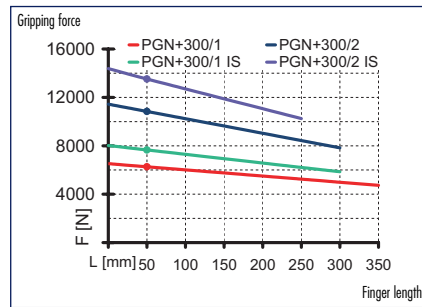

## Gripping force, O.D. gripping

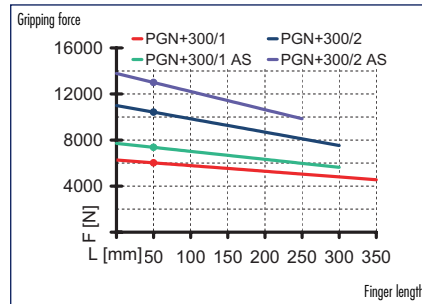

## Finger load

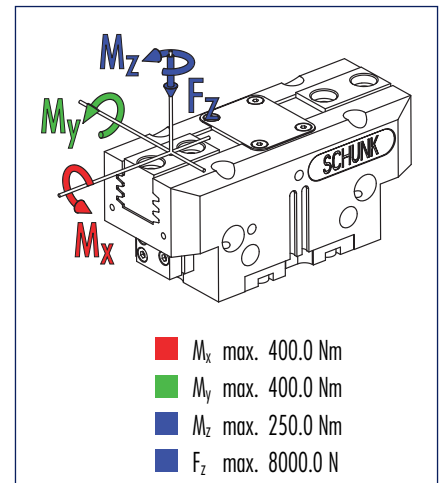

① Moments and forces apply per base jaw and may occur simultaneously.  $M_y$  may arise in addition to the moment generated by the gripping force itself. If the max. permitted finger weight is exceeded, it is imperative to throttle the air pressure so that the jaw movement occurs without any hitting or bouncing. Service life may reduce.

## Technical data

Description		PGN-plus 300-1	PGN-plus 300-2	PGN-plus 300-1-AS	PGN-plus 300-2-AS	PGN-plus 300-1-IS	PGN-plus 300-2-IS
	ID	0371106	0371156	0371406	0371456	0371466	0371476
Stroke per jaw	[mm]	35.0	20.0	35.0	20.0	35.0	20.0
Closing force	[N]	6000.0	10300.0	7400.0	12500.0		
Opening force	[N]	6260.0	10800.0			7660.0	13000.0
Min. spring force	[N]			1400.0	2200.0	1400.0	2200.0
Weight	[kg]	13.9	13.9	17.2	17.2	17.2	17.2
Recommended workpiece weight	[kg]	30.0	51.5	30.0	51.5	30.0	51.5
Air consumption per double stroke	[cm <sup>3</sup> ]	1030.0	1030.0	1030.0	1030.0	1030.0	1030.0
Minimum pressure	[bar]	2.5	2.5	4.0	4.0	4.0	4.0
Maximum pressure	[bar]	8.0	8.0	6.5	6.5	6.5	6.5
Nominal pressure	[bar]	6.0	6.0	6.0	6.0	6.0	6.0
Closing time	[s]	0.5	0.5	0.4	0.4	0.7	0.7
Opening time	[s]	0.5	0.5	0.7	0.7	0.4	0.4
Max. permitted finger length	[mm]	350.0	300.0	300.0	250.0	300.0	250.0
Max. permitted weight per finger	[kg]	11.5	11.5	11.5	11.5	11.5	11.5
IP rating		40	40	40	40	40	40
Min. ambient temperature	[°C]	-10.0	-10.0	-10.0	-10.0	-10.0	-10.0
Température ambiante max.	[°C]	90.0	90.0	90.0	90.0	90.0	90.0
Repeat accuracy	[mm]	0.05	0.05	0.05	0.05	0.05	0.05

### OPTIONS and their characteristics

Dust-protection version	ID	37371106	37371156	37371406	37371456	37371466	37371476
IP rating		64	64	64	64	64	64
Weight	[kg]	17.6	17.6	21.3	21.3	21.3	21.3
Anti-corrosion version	ID	38371106	38371156	38371406	38371456	38371466	38371476
High-temperature version	ID	39371106	39371156	39371406	39371456	39371466	39371476
Min. ambient temperature	[°C]	-10.0	-10.0	-10.0	-10.0	-10.0	-10.0
Température ambiante max.	[°C]	130.0	130.0	130.0	130.0	130.0	130.0

### Main views

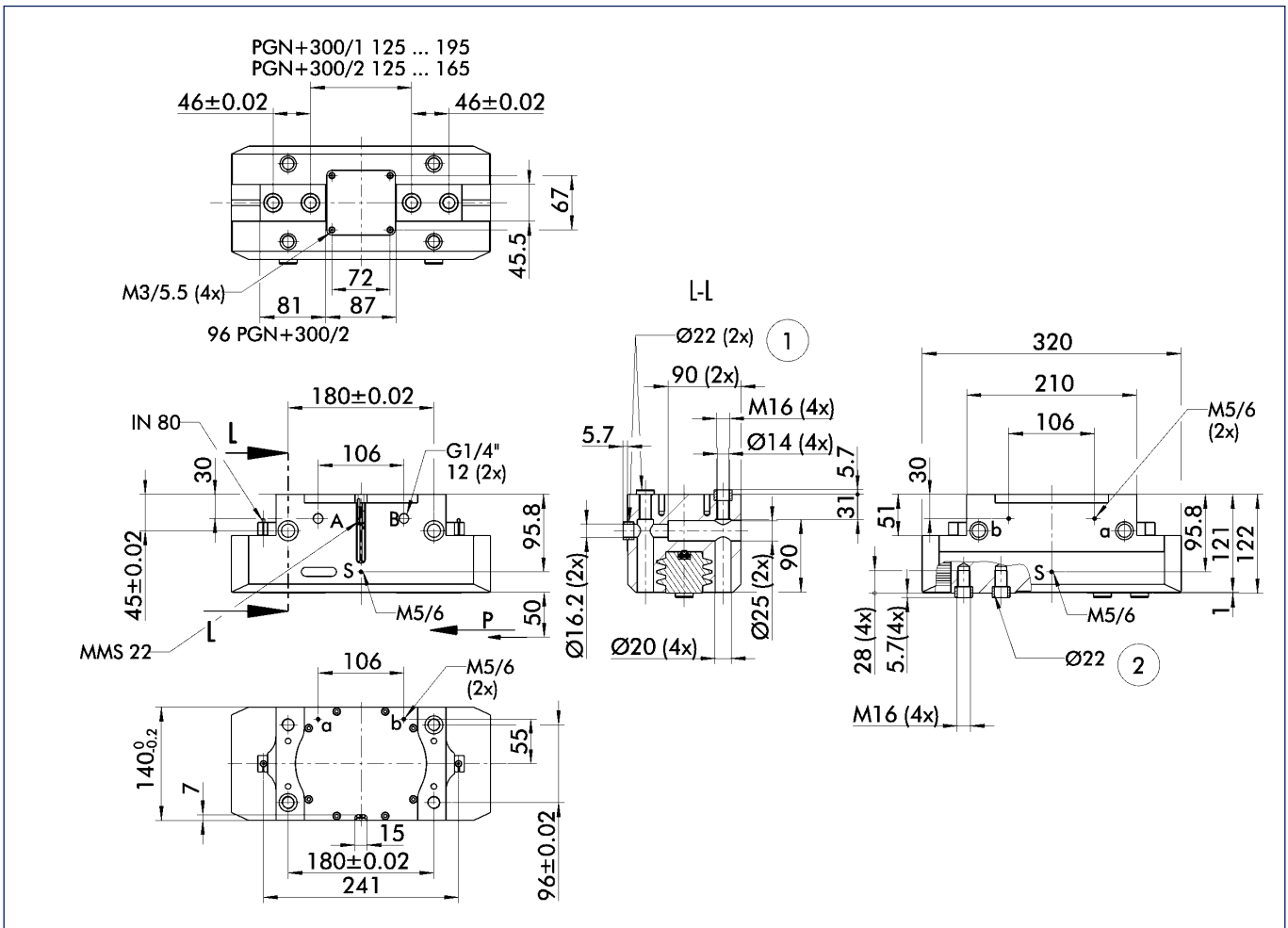

The drawing shows the gripper in the basic version with closed jaws, the dimensions do not include the options described below.

① The SDV-P pressure maintenance valve can also be used (see „Accessories“ catalog section) for I.D. or O.D. gripping as an alternative or in addition to the spring-loaded, mechanical gripping force safety device.

- A,a Main/direct connection, gripper opening
- B,b Main/direct connection, gripper closing
- S,s Air purge or ventilation hole
- ① Gripper connection
- ② Finger connection

### Hose-free direct connection

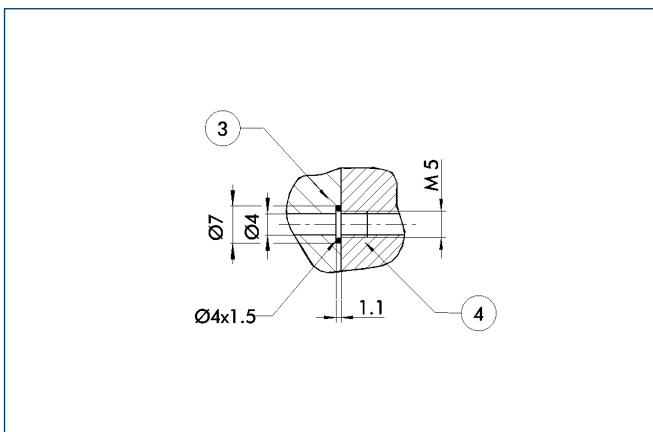

③ Adapter

④ Gripper

The direct connection is used for supplying compressed air to the gripper without hoses. Instead, the pressure medium is fed through bore-holes in the mounting plate.

### AS/IS gripping force safety device

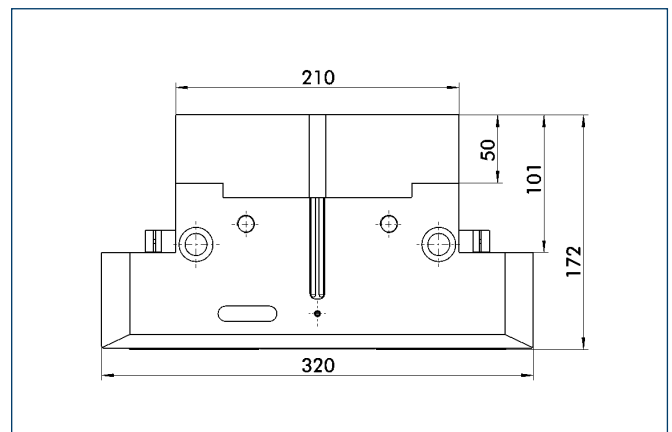

The mechanical gripping force safety device ensures a minimum gripping force even if there is a drop in pressure. This acts as closing force in the AS version, and as opening force in the IS version. In addition, the gripping force safety device can also be employed as a gripping force booster or for single-acting gripping.

# PGN-plus 300

Pneumatic · 2-Finger Parallel Gripper · Universal Gripper

## Version with dust cover

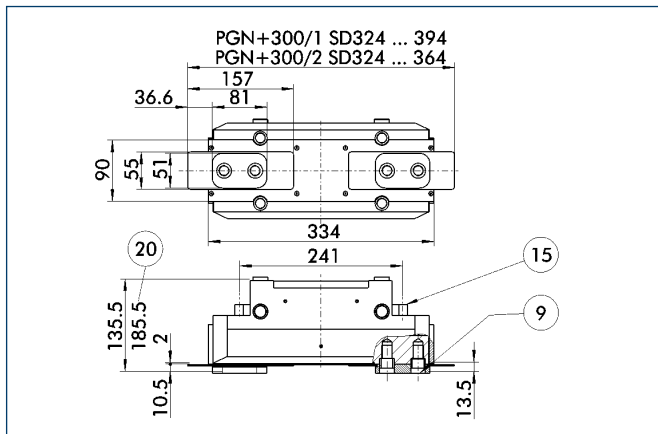

- ⑨ For screw connection diagram, see basic version
- ⑮ Sealing bolt
- ⑳ With AS / IS version

The „dust-protection“ option increases the degree of protection against penetrating substances. The screw connection diagram shifts by the height of the intermediate jaw. The finger length is still measured from the upper edge of the gripper housing.

## Finger blanks

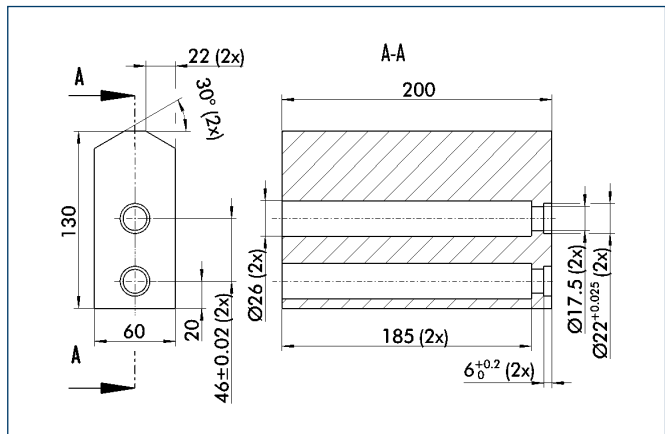

Finger blanks for customized subsequent machining, incl. screw connection diagram

Description	Material	Scope of delivery	ID
ABR-plus 300	Aluminum	1	0300016
SBR-plus 300	16 MnCr 5	1	0300026

## FMS force measuring jaws

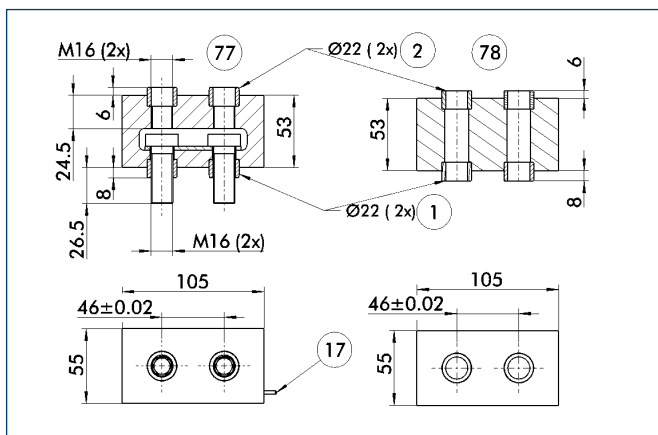

- ① Gripper connection
- ② Finger connection
- ⑰ Cable outlet
- ⑳ Active intermediate jaws
- ㉑ Passiv intermediate jaws

Force measuring jaws measure gripping forces, but can also determine workpiece weights or dimensional deviations. There are active and passive intermediate jaws (FMS-ZBA or FMS-ZBP). At least one active force measuring jaw is required per gripper, the rest can be passive. For each active jaw, an FMS-A1 control unit and an FMS-A connection cable are required.

Description	ID
FMS-A2	0301811
FMS-AK0200	0301820
FMS-AK0500	0301821
FMS-AK1000	0301822
FMS-AK2000	0301823
FMS-ZBA 300	0301846
FMS-ZBP 300	0301847

 You can find more detailed information and individual parts of the above-mentioned accessories in the „Accessories“ catalog section.



### Sensor system

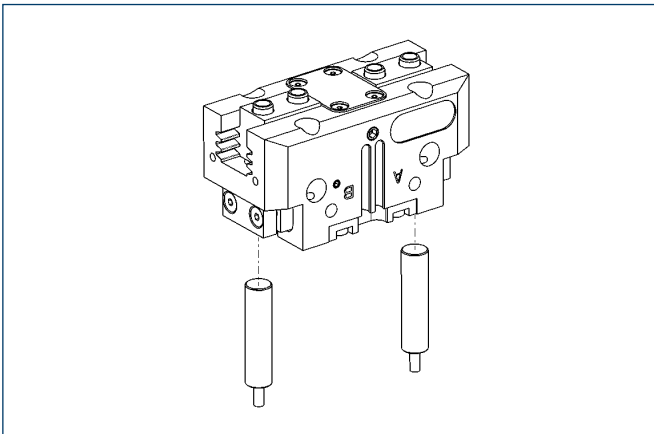

#### End position monitoring: Inductive proximity switches, for direct mounting

Description	ID	Recommended product
IN 80-S-M12	0301578	
IN 80-S-M8	0301478	•
INK 80-S	0301550	

① Two sensors (NO contacts) are required for each gripper, plus extension cables as an option.

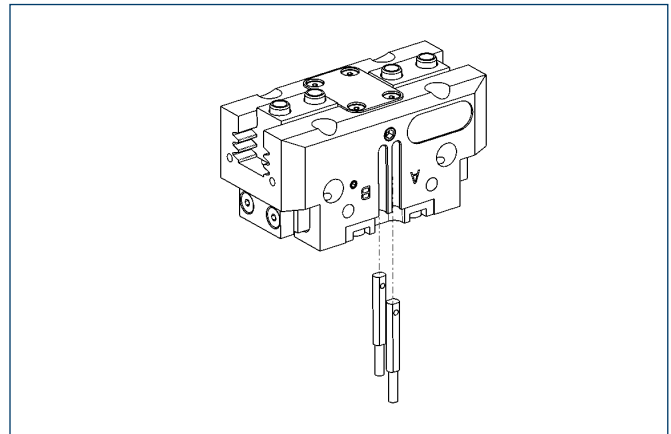

#### End position monitoring: Electronic magnetic switches, for mounting in C-slot

Description	ID	Recommended product
MMS 22-S-M5-NPN	0301439	
MMS 22-S-M5-NPN-SA	0301449	
MMS 22-S-M5-PNP	0301438	
MMS 22-S-M5-PNP-SA	0301448	
MMS 22-S-M8-NPN	0301433	
MMS 22-S-M8-NPN-SA	0301443	
MMS 22-S-M8-PNP	0301432	•
MMS 22-S-M8-PNP-SA	0301442	
MMSK 22-S-NPN	0301435	
MMSK 22-S-NPN-SA	0301445	
MMSK 22-S-PNP	0301434	
MMSK 22-S-PNP-SA	0301444	

① Two sensors (NO contacts) are required for each gripper, plus extension cables as an option.

#### Extension cables for proximity switches/magnetic switches

Description	ID
KA BG05-L 3P-0300	0301652
KA BG08-L 3P-0300-PNP	0301622
KA BW05-L 3P-0300	0301650
KA BW08-L 3P-0300-NPN	0301602
KA BW08-L 3P-0300-PNP	0301594
KA BW08-L 3P-0500-NPN	9641116
KA BW08-L 3P-0500-PNP	0301502
KA BW12-L 3P-0300-PNP	0301503
KA BW12-L 3P-0500-PNP	0301507
KV BW08-SG08 3P-0030-PNP	0301495
KV BW08-SG08 3P-0100-PNP	0301496
KV BW08-SG08 3P-0200-PNP	0301497
KV BW12-SG12 3P-0030-PNP	0301595
KV BW12-SG12 3P-0100-PNP	0301596
KV BW12-SG12 3P-0200-PNP	0301597

① Please note the minimum permitted bending radii for the sensor cables, which are generally 35 mm.



You can find more detailed information and individual parts of the above-mentioned accessories in the „Accessories“ catalog section.

### Sensor system

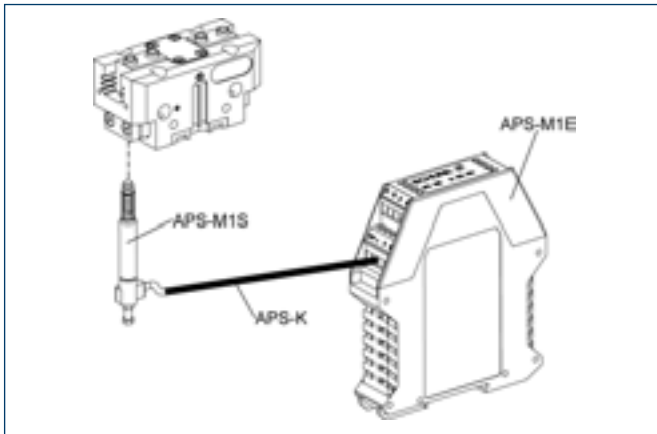

Measuring system:  
APS Analog position sensor

Description	ID
APS-K0200	0302066
APS-K0700	0302068
APS-M1E	0302064
APS-M1S	0302062
AS-APS-M1-300/1	0302088
AS-APS-M1-300/2	0302089

- ① When using an APS system, a mounting kit (AS-APS, incl. 3 m cable), an APS sensor (APS-M1S) and electronics (APS-M1E) are required for each gripper. An extension cable (APS-K) can be connected between the sensor and the electronics as an option. The max. cable length between the sensor and the electronics is 10 m, between the electronics and their control unit (PLC) it is max. 1 m.

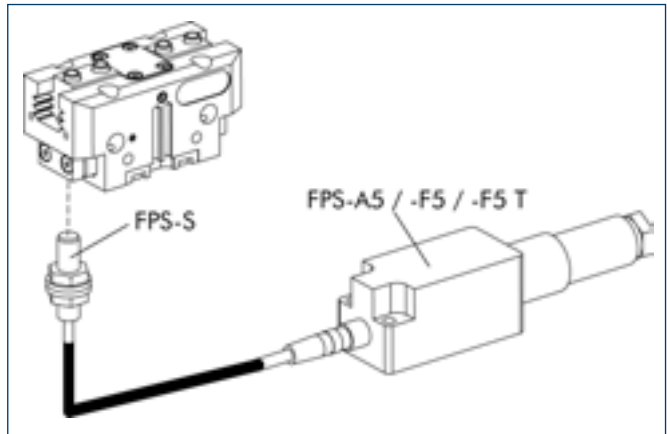

Measuring system:  
FPS Flexible position sensor

Description	ID
AS-PGN/PZN-plus 300-2	0301642
FPS-F5	0301805
FPS-F5 T	0301807
FPS-S M8	0301704

- ① When using an FPS system, an FPS sensor (FPS-S) and an control unit (FPS-F5 / F5 T or A5) are required for each gripper as well as a mounting kit (AS), if listed. Cable extensions (KV) are available as options in the „Accessories“ catalog section.

### Maximum permitted finger offset

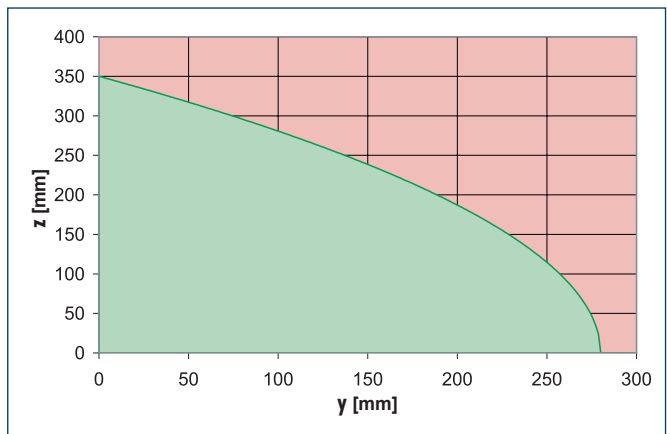
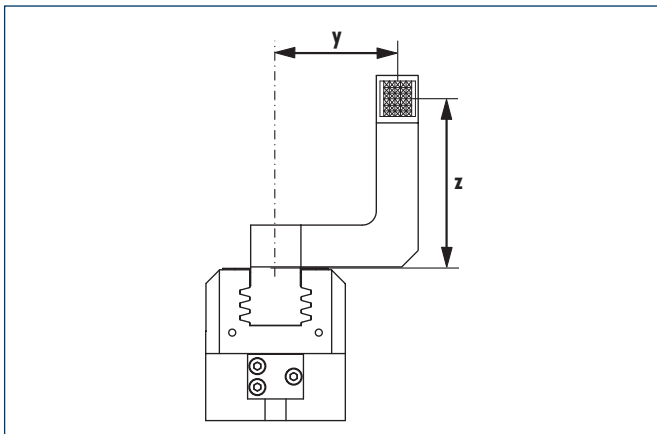

- Permitted range  
■ Non-permissible range

The curve applies to the basic version (stroke -1). For other versions, the curve will be parallel but offset in line with the max. permitted finger length.



You can find more detailed information and individual parts of the above-mentioned accessories in the „Accessories“ catalog section.

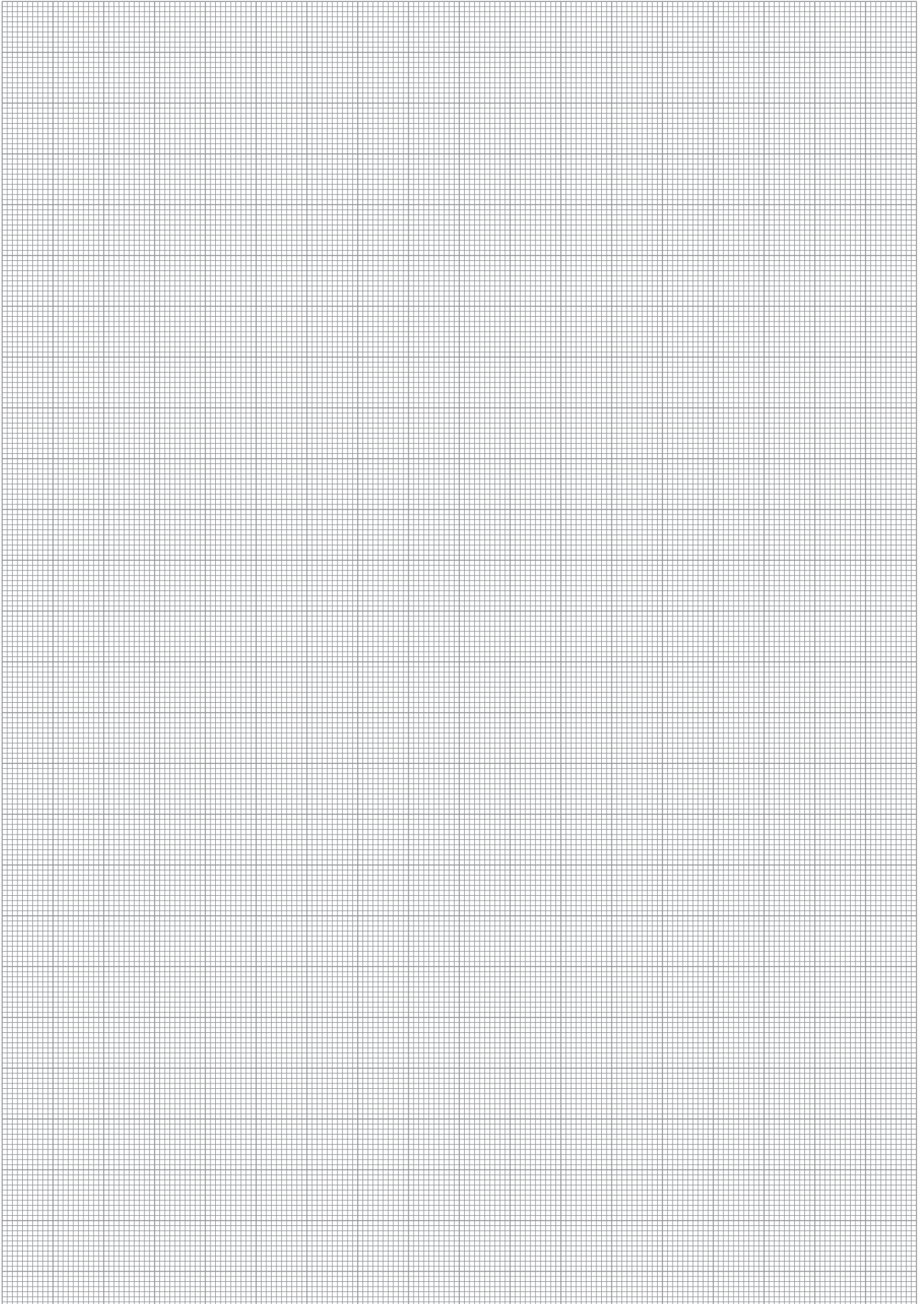

# PGN-plus 380

Pneumatic · 2-Finger Parallel Gripper · Universal Gripper



## Gripping force, I.D. gripping

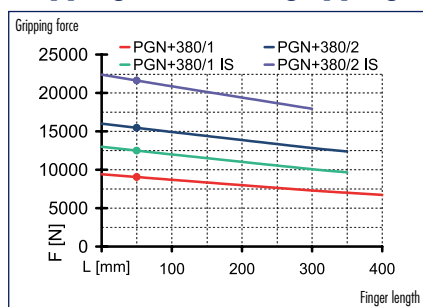

## Gripping force, O.D. gripping

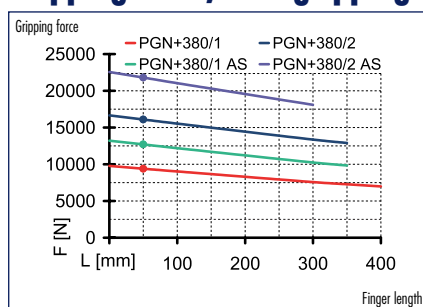

## Finger load

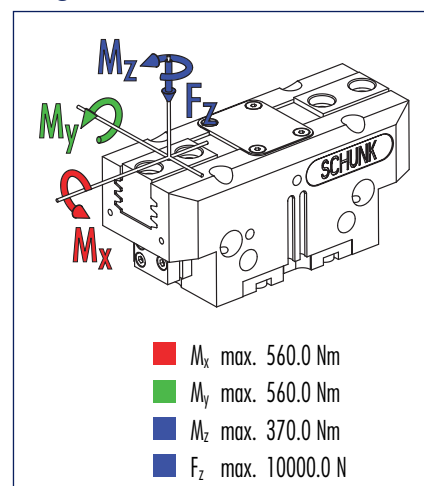

① Moments and forces apply per base jaw and may occur simultaneously.  $M_y$  may arise in addition to the moment generated by the gripping force itself. If the max. permitted finger weight is exceeded, it is imperative to throttle the air pressure so that the jaw movement occurs without any hitting or bouncing. Service life may reduce.

## Technical data

Description		PGN-plus 380-1	PGN-plus 380-2	PGN-plus 380-1-AS	PGN-plus 380-2-AS	PGN-plus 380-1-IS	PGN-plus 380-2-IS
	ID	0371107	0371157	0371407	0371457	0371467	0371477
Stroke per jaw	[mm]	45.0	26.0	45.0	26.0	45.0	26.0
Closing force	[N]	9050.0	15450.0	12350.0	21150.0		
Opening force	[N]	9400.0	16100.0			12700.0	21800.0
Min. spring force	[N]			3300.0	5700.0	3300.0	5700.0
Weight	[kg]	28.0	29.0	36.5	37.5	36.5	37.5
Recommended workpiece weight	[kg]	47.0	80.5	47.0	80.5	47.0	80.5
Air consumption per double stroke	[cm <sup>3</sup> ]	1714.0	1714.0	1714.0	1714.0	1714.0	1714.0
Minimum pressure	[bar]	2.5	2.5	4.0	4.0	4.0	4.0
Maximum pressure	[bar]	8.0	8.0	6.5	6.5	6.5	6.5
Nominal pressure	[bar]	6.0	6.0	6.0	6.0	6.0	6.0
Closing time	[s]	0.6	0.6	0.5	0.5	0.8	0.8
Opening time	[s]	0.6	0.6	0.8	0.8	0.5	0.5
Max. permitted finger length	[mm]	400.0	350.0	350.0	300.0	350.0	300.0
Max. permitted weight per finger	[kg]	17.0	17.0	17.0	17.0	17.0	17.0
IP rating		40	40	40	40	40	40
Min. ambient temperature	[°C]	-10.0	-10.0	-10.0	-10.0	-10.0	-10.0
Température ambiante max.	[°C]	90.0	90.0	90.0	90.0	90.0	90.0
Repeat accuracy	[mm]	0.05	0.05	0.05	0.05	0.05	0.05

### OPTIONS and their characteristics

Dust-protection version	ID	37371107	37371157	37371407	37371457	37371467	37371477
IP rating		64	64	64	64	64	64
Weight	[kg]	30.0	31.0	38.5	39.5	38.5	39.5
Anti-corrosion version	ID	38371107	38371157	38371407	38371457	38371467	38371477
High-temperature version	ID	39371107	39371157	39371407	39371457	39371467	39371477
Min. ambient temperature	[°C]	-10.0	-10.0	-10.0	-10.0	-10.0	-10.0
Température ambiante max.	[°C]	130.0	130.0	130.0	130.0	130.0	130.0

### Main views

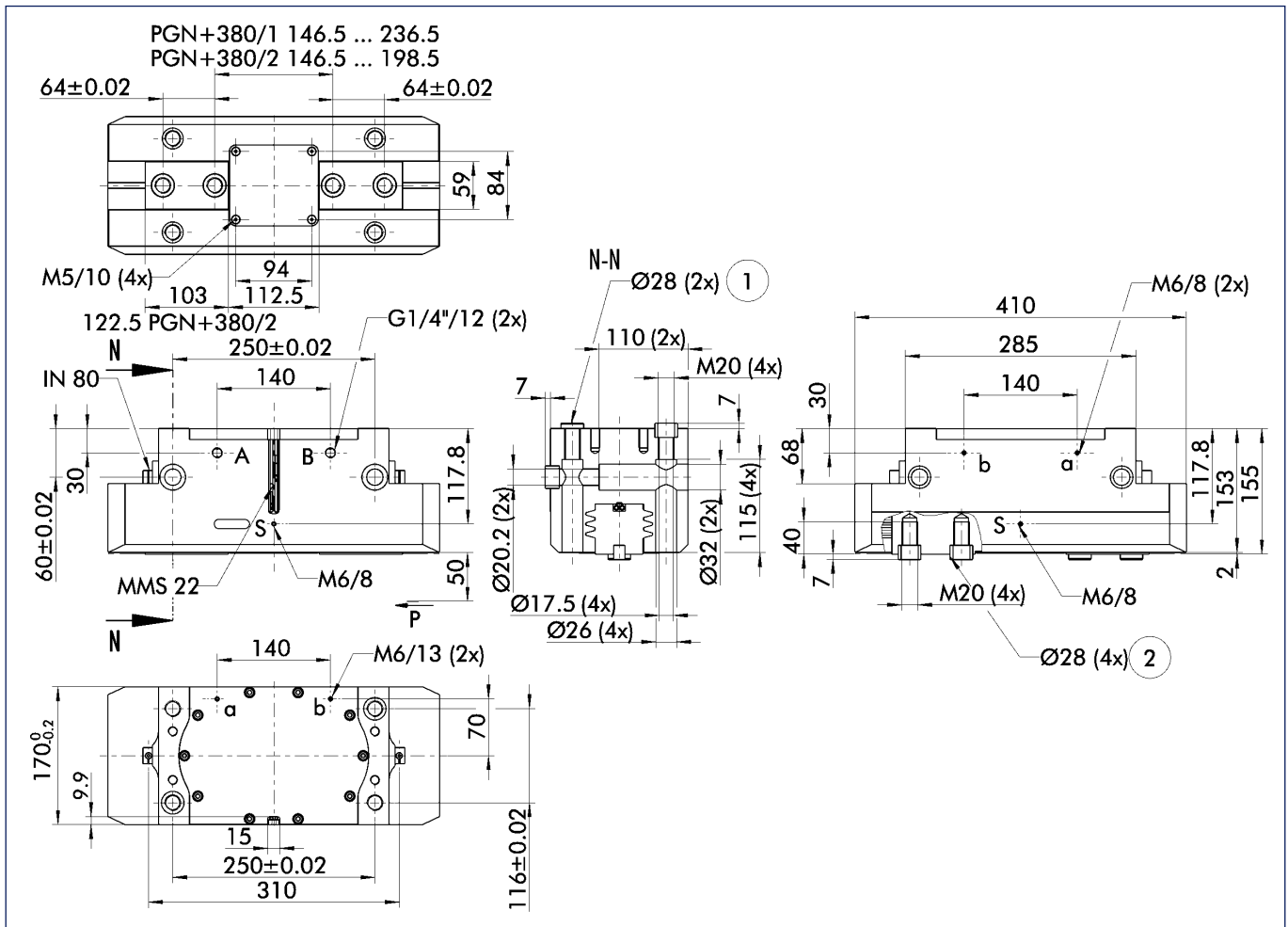

The drawing shows the gripper in the basic version with closed jaws, the dimensions do not include the options described below.

① The SDV-P pressure maintenance valve can also be used (see „Accessories“ catalog section) for I.D. or O.D. gripping as an alternative or in addition to the spring-loaded, mechanical gripping force safety device.

- A,a Main/direct connection, gripper opening
- B,b Main/direct connection, gripper closing
- S,s Air purge or ventilation hole
- ① Gripper connection
- ② Finger connection

### Hose-free direct connection

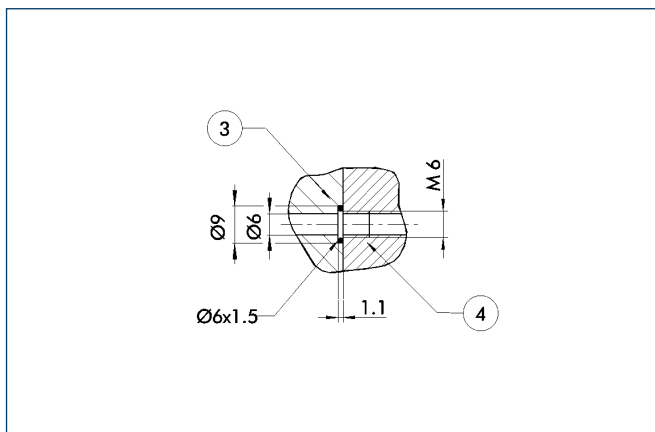

③ Adapter

④ Gripper

The direct connection is used for supplying compressed air to the gripper without hoses. Instead, the pressure medium is fed through bore-holes in the mounting plate.

### AS/IS gripping force safety device

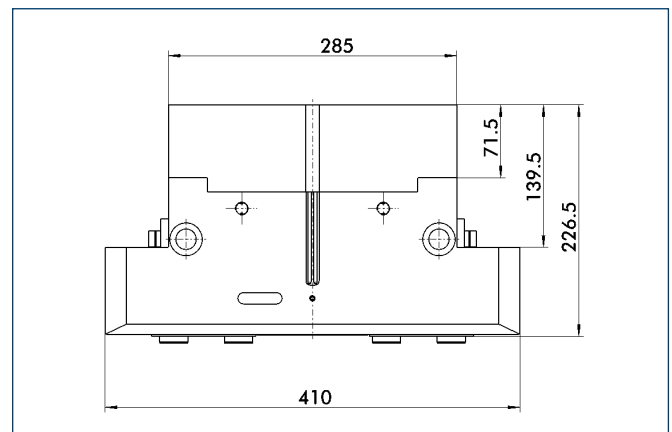

The mechanical gripping force safety device ensures a minimum gripping force even if there is a drop in pressure. This acts as closing force in the AS version, and as opening force in the IS version. In addition, the gripping force safety device can also be employed as a gripping force booster or for single-acting gripping.

# PGN-plus 380

Pneumatic · 2-Finger Parallel Gripper · Universal Gripper

## Version with dust cover

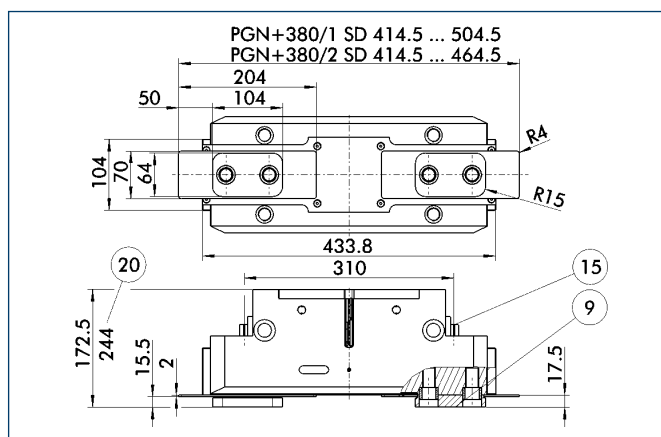

- ⑨ For screw connection diagram, see basic version
- ⑮ Sealing bolt
- ⑳ With AS / IS version

The „dust-protection“ option increases the degree of protection against penetrating substances. The screw connection diagram shifts by the height of the intermediate jaw. The finger length is still measured from the upper edge of the gripper housing.

### Sensor system

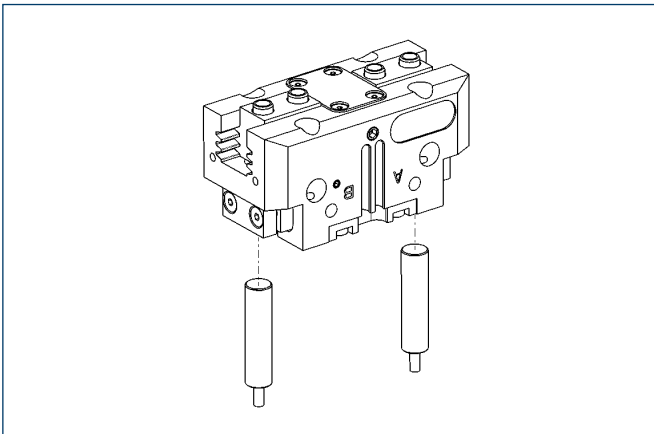

End position monitoring:  
Inductive proximity switches, for direct mounting

Description	ID	Recommended product
IN 80-S-M12	0301578	
IN 80-S-M8	0301478	•
INK 80-S	0301550	

① Two sensors (NO contacts) are required for each gripper, plus extension cables as an option.

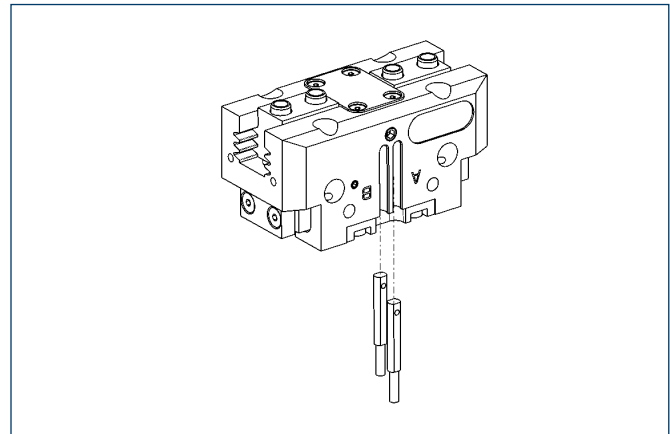

End position monitoring:  
Electronic magnetic switches, for mounting in C-slot

Description	ID	Recommended product
MMS 22-S-M5-NPN	0301439	
MMS 22-S-M5-NPN-SA	0301449	
MMS 22-S-M5-PNP	0301438	
MMS 22-S-M5-PNP-SA	0301448	
MMS 22-S-M8-NPN	0301433	
MMS 22-S-M8-NPN-SA	0301443	
MMS 22-S-M8-PNP	0301432	•
MMS 22-S-M8-PNP-SA	0301442	
MMSK 22-S-NPN	0301435	
MMSK 22-S-NPN-SA	0301445	
MMSK 22-S-PNP	0301434	
MMSK 22-S-PNP-SA	0301444	

① Two sensors (NO contacts) are required for each gripper, plus extension cables as an option.

### Extension cables for proximity switches/magnetic switches

Description	ID
KA BG05-L 3P-0300	0301652
KA BG08-L 3P-0300-PNP	0301622
KA BW05-L 3P-0300	0301650
KA BW08-L 3P-0300-NPN	0301602
KA BW08-L 3P-0300-PNP	0301594
KA BW08-L 3P-0500-NPN	9641116
KA BW08-L 3P-0500-PNP	0301502
KA BW12-L 3P-0300-PNP	0301503
KA BW12-L 3P-0500-PNP	0301507
KV BW08-SG08 3P-0030-PNP	0301495
KV BW08-SG08 3P-0100-PNP	0301496
KV BW08-SG08 3P-0200-PNP	0301497
KV BW12-SG12 3P-0030-PNP	0301595
KV BW12-SG12 3P-0100-PNP	0301596
KV BW12-SG12 3P-0200-PNP	0301597

① Please note the minimum permitted bending radii for the sensor cables, which are generally 35 mm.



You can find more detailed information and individual parts of the above-mentioned accessories in the „Accessories“ catalog section.

# PGN-plus 380

Pneumatic · 2-Finger Parallel Gripper · **Universal Gripper**

## Sensor system

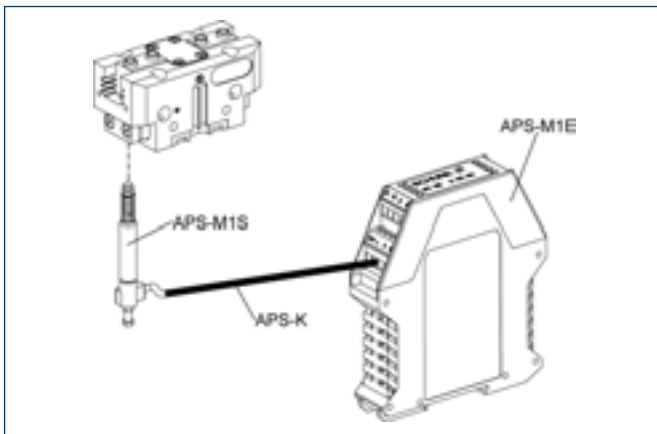

Measuring system:

APS Analog position sensor

Description	ID
APS-K0200	0302066
APS-K0700	0302068
APS-M1E	0302064
APS-M1S	0302062
AS-APS-M1-200/1 und 380/2	0302085
AS-APS-M1-380/1	0302090

- ① When using an APS system, a mounting kit (AS-APS, incl. 3 m cable), an APS sensor (APS-M1S) and electronics (APS-M1E) are required for each gripper. An extension cable (APS-K) can be connected between the sensor and the electronics as an option. The max. cable length between the sensor and the electronics is 10 m, between the electronics and their control unit (PLC) it is max. 1 m.

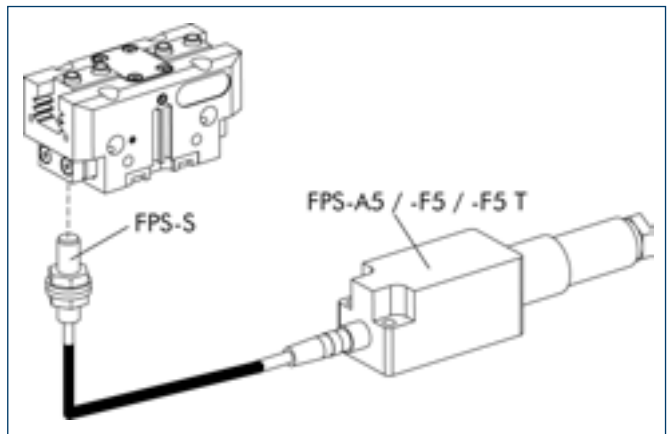

Measuring system:

FPS Flexible position sensor

Description	ID
AS-PGN-plus 380-2	0301645
FPS-F5	0301805
FPS-F5 T	0301807
FPS-S M8	0301704

- ① When using an FPS system, an FPS sensor (FPS-S) and an control unit (FPS-F5 / F5 T or A5) are required for each gripper as well as a mounting kit (AS), if listed. Cable extensions (KV) are available as options in the „Accessories“ catalog section.

## Maximum permitted finger offset

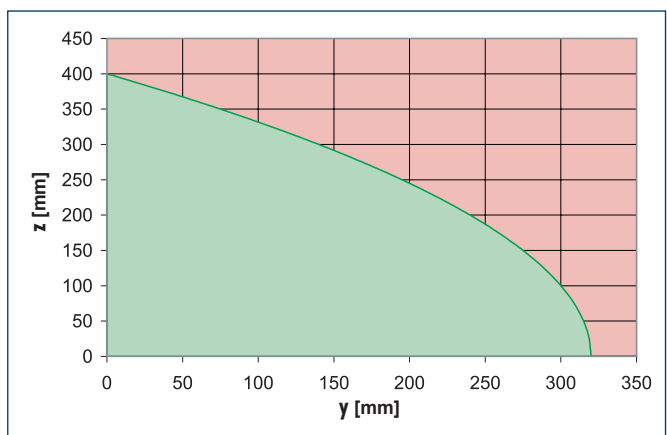
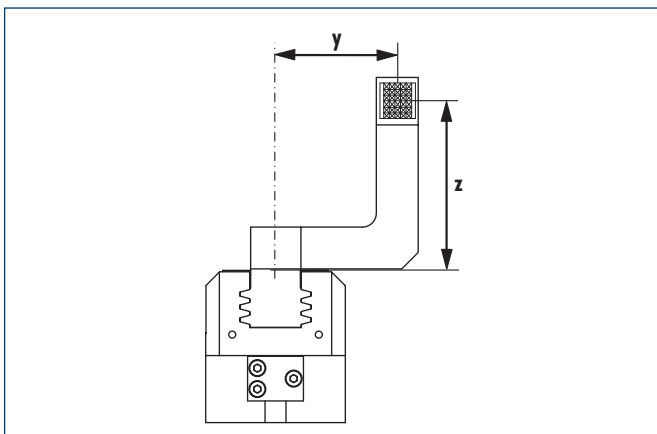

- Permitted range
- Non-permissible range

The curve applies to the basic version (stroke -1). For other versions, the curve will be parallel but offset in line with the max. permitted finger length.



You can find more detailed information and individual parts of the above-mentioned accessories in the „Accessories“ catalog section.