

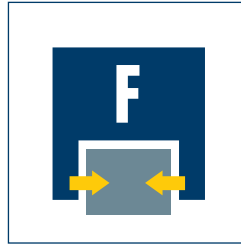

**Sizes**  
29 .. 140



**Weight**  
0.025 kg .. 2.55 kg



**Gripping force**  
30 N .. 1180 N



**Stroke per finger**  
2 mm .. 15 mm



**Workpiece weight**  
0.15 kg .. 5.9 kg

### Application example

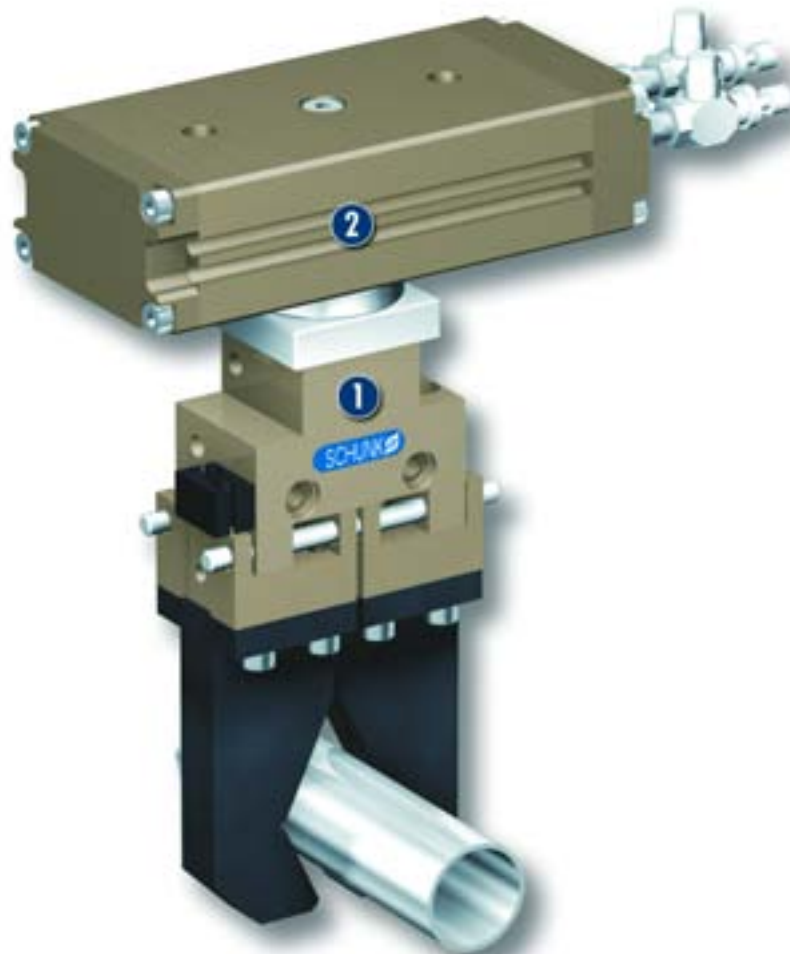

Reversing unit for the economical reorientation of cylindrical bar material

**1** PGM 50 2-Finger Parallel Gripper with workpiece-specific gripper fingers

**2** MRU 14.1-E-0 Miniature Rotary Actuator

## Universal Gripper

Universal, economical 2-finger parallel gripper

### Area of application

for universal use in clean environments

### Your advantages and benefits

**Economical gripper series**

for material handling

**Rod guide for base jaws**

for excellent guidance characteristics

**Cylinder rod guidance**

for versatility and a long tool life

**Compact design**

for minimal interfering contours in the application

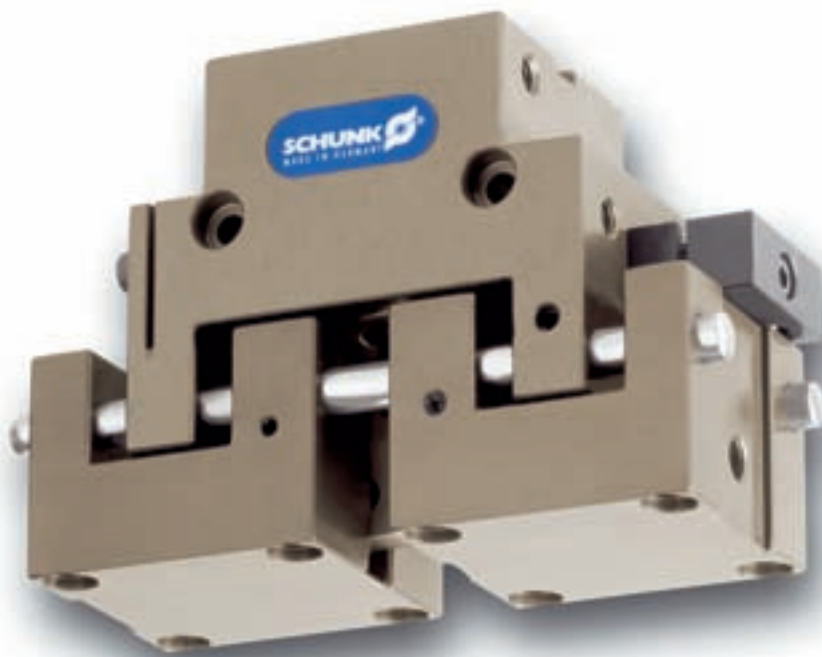

### General information on the series

**Working principle**

Interior wedge-hook kinematics

**Housing material**

Aluminum alloy, hard-anodized

**Guide**

Steel guide, ground and hardened

**Actuation**

Pneumatic, with filtered compressed air (10 µm): Dry, lubricated or non-lubricated

Pressure medium: Requirements on quality of the compressed air according to

DIN ISO 8573-1: 6 4 4.

**Warranty**

24 months

**Scope of delivery**

Brackets for proximity switches, centering sleeves, assembly and operating manual with manufacturer's declaration

## Sectional diagram

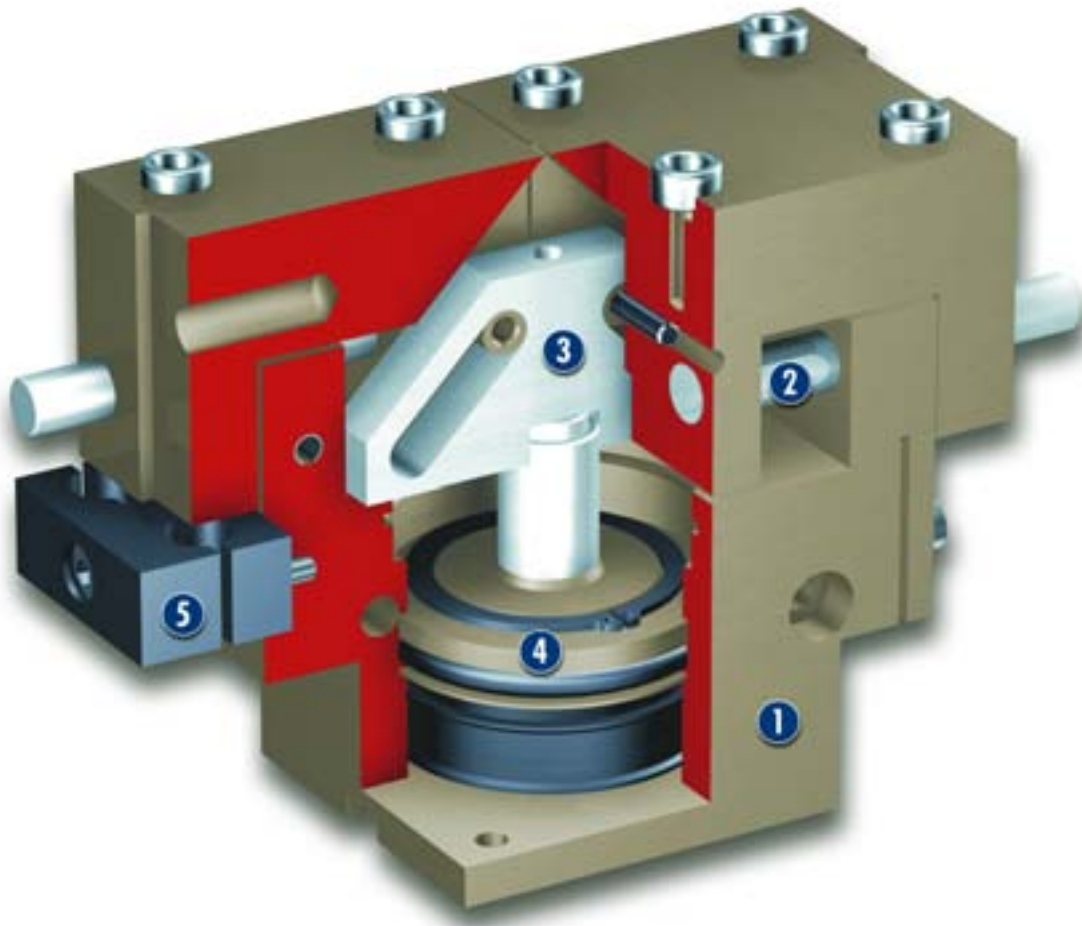

- 1 Housing**  
weight-reduced through the use of a hard-anodized, high-strength aluminum alloy
- 3 Kinematics**  
internal, power transmission via line contact
- 5 Sensor system**  
mounting brackets for inductive proximity switches
- 2 Rod guide**  
simple yet resilient
- 4 Drive**  
using tried and tested pneumatic piston drive

## Function description

The piston is moved up and down by compressed air. The wedge hook, together with the transverse rods of the base jaws, transforms the piston motion into synchronized opening and closing.

## Options and special information

The PGM series is a product line with an important cost/benefit ratio.

**Accessories**

Accessories from SCHUNK – the suitable supplement for maximum functionality, reliability and performance of all automation modules.

Centering sleeves

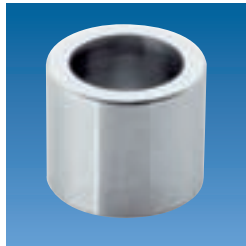

Fittings



IN inductive proximity switches

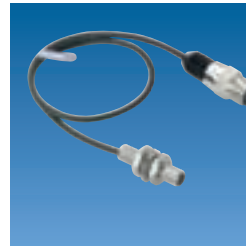

KV/KA sensor cables



SDV-P pressure maintenance valves

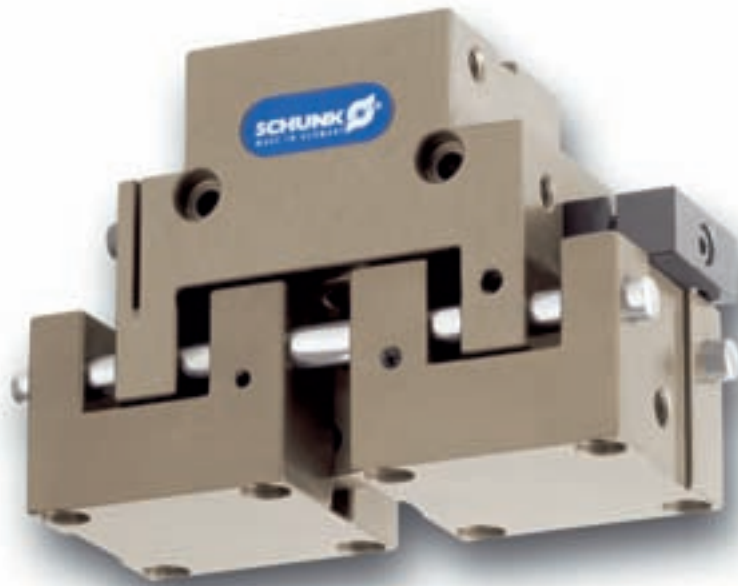

V sensor distributors



① For the exact size of the required accessories, availability of this size and the designation and ID, please refer to the additional views at the end of the size in question. You will find more detailed information on our accessory range in the „Accessories“ catalog section.

**General information on the series**

**Gripping force**

is the arithmetic total of the gripping force applied to each claw jaw at distance P (see illustration), measured from the upper edge of the gripper.

**Finger length**

is measured from the upper edge of the gripper housing in the direction of the main axis.

**Repeat accuracy**

is defined as the spread of the limit position after 100 consecutive strokes.

**Workpiece weight**

The recommended workpiece weight is calculated for a force-type connection with a coefficient of friction of 0.1 and a safety factor of 2 against slippage of the workpiece on acceleration due to gravity g. Considerably heavier workpiece weights are permitted with form-fit gripping.

**Closing and opening times**

Closing and opening times are purely the times that the base jaws or base fingers are in motion. Valve switching times, hose filling times or PLC reaction times are not included in the above times and must be taken into consideration when determining cycle times.

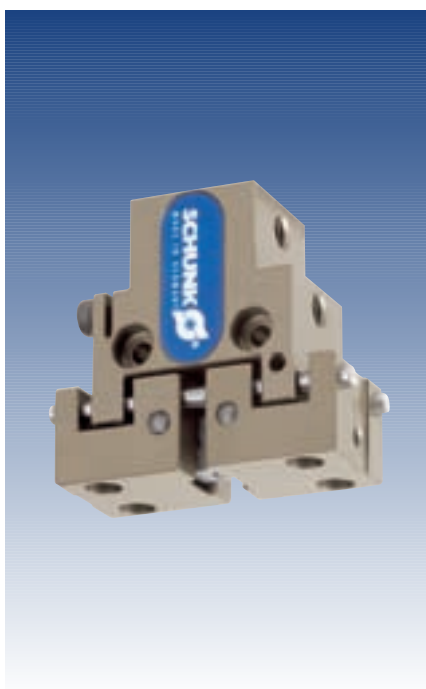

### Gripping force, I.D. gripping

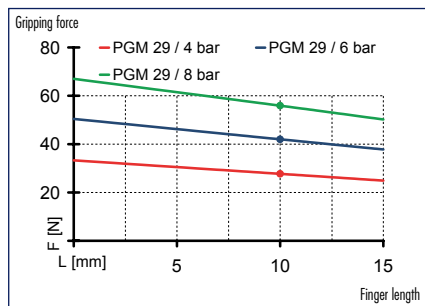

### Gripping force, O.D. gripping

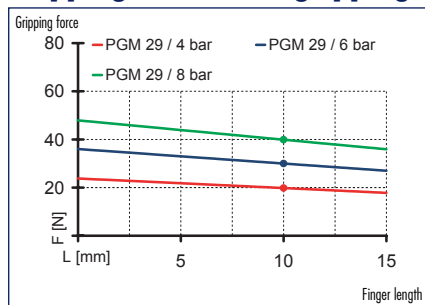

### Finger load

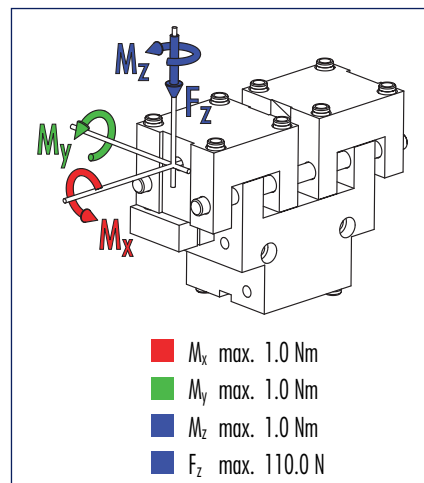

① Moments and forces apply per base jaw and may occur simultaneously.  $M_y$  may arise in addition to the moment generated by the gripping force itself. If the max. permitted finger weight is exceeded, it is imperative to throttle the air pressure so that the jaw movement occurs without any hitting or bouncing. Service life may reduce.

## Technical data

Description	PGM 29	
	ID	0302680
Stroke per finger	[mm]	2.0
Closing force	[N]	30.0
Opening force	[N]	40.0
Weight	[kg]	0.025
Recommended workpiece weight	[kg]	0.15
Air consumption per double stroke	[cm <sup>3</sup> ]	0.16
Nominal pressure	[bar]	6.0
Minimum pressure	[bar]	2.0
Maximum pressure	[bar]	8.0
Closing time	[s]	0.03
Opening time	[s]	0.03
Max. permitted finger length	[mm]	15.0
Max. permitted weight per finger	[kg]	0.01
IP class		30
Min. ambient temperature	[°C]	-10.0
Max. ambient temperature	[°C]	90.0
Repeat accuracy	[mm]	0.02

### Main views

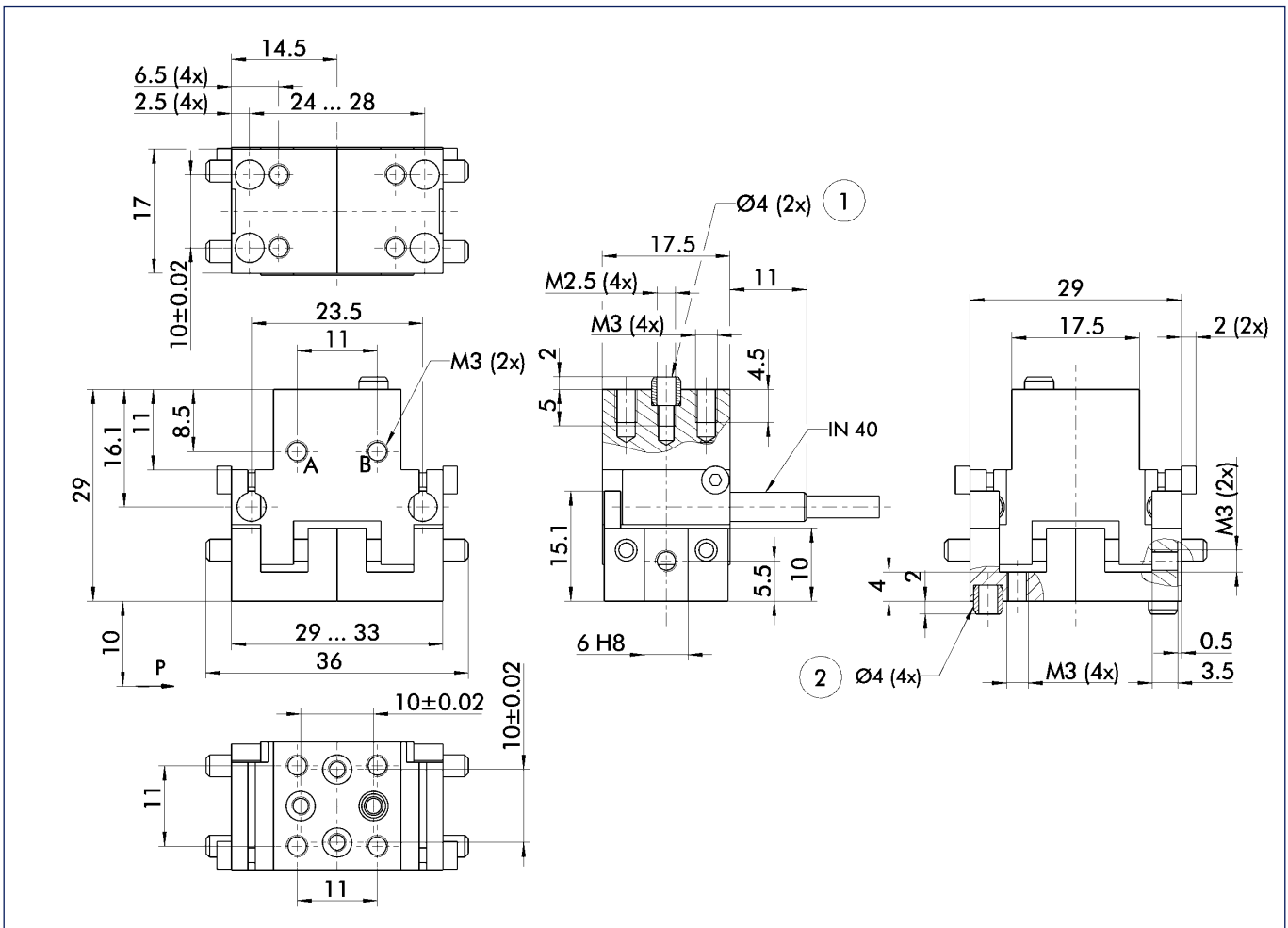

The drawing shows the gripper in the basic version with closed jaws, the dimensions do not include the options described below.

- A,a Main/direct connection, gripper opening
- B,b Main/direct connection, gripper closing
- ① Gripper connection
- ② Finger connection

① The SDV-P pressure maintenance valve can be used as a gripping force safety device (see „Accessories“ catalog section).

### Maximum permitted finger offset

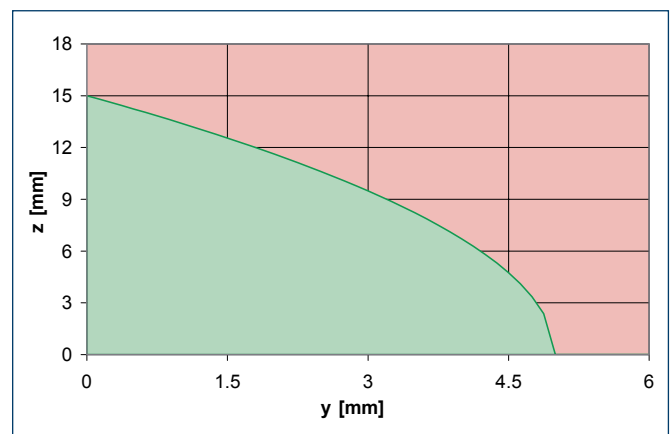
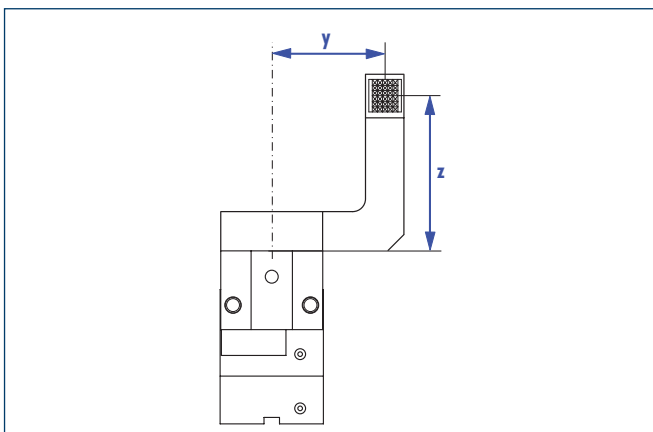

- Permitted range
- Non-permissible range

### Sensor system

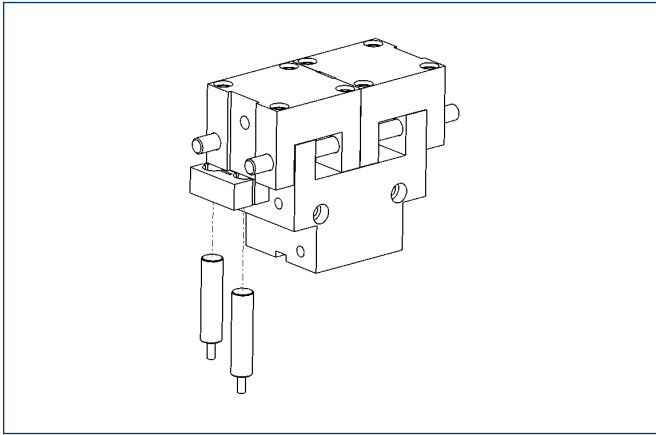

#### End position monitoring:

#### Inductive proximity switches, for direct mounting

Description	ID	Recommended product
IN 40-S-M12	0301574	
IN 40-S-M5-NPN	0301492	
IN 40-S-M5-PNP	0301491	
IN 40-S-M8	0301474	•
INK 40-S	0301555	

① Two sensors (NO contacts) are required for each gripper, plus extension cables as an option.

#### Extension cables for proximity switches/magnetic switches

Description	ID
KA BG05-L 3P-0300	0301652
KA BG08-L 3P-0300-PNP	0301622
KA BW05-L 3P-0300	0301650
KA BW08-L 3P-0300-PNP	0301594
KA BW08-L 3P-0500-PNP	0301502
KA BW12-L 3P-0300-PNP	0301503
KA BW12-L 3P-0500-PNP	0301507
KV BW08-SG08 3P-0030-PNP	0301495
KV BW08-SG08 3P-0100-PNP	0301496
KV BW08-SG08 3P-0200-PNP	0301497
KV BW12-SG12 3P-0030-PNP	0301595
KV BW12-SG12 3P-0100-PNP	0301596
KV BW12-SG12 3P-0200-PNP	0301597

① Please note the minimum permitted bending radii for the sensor cables, which are generally 35 mm.



You can find more detailed information and individual parts of the above-mentioned accessories in the „Accessories“ catalog section.

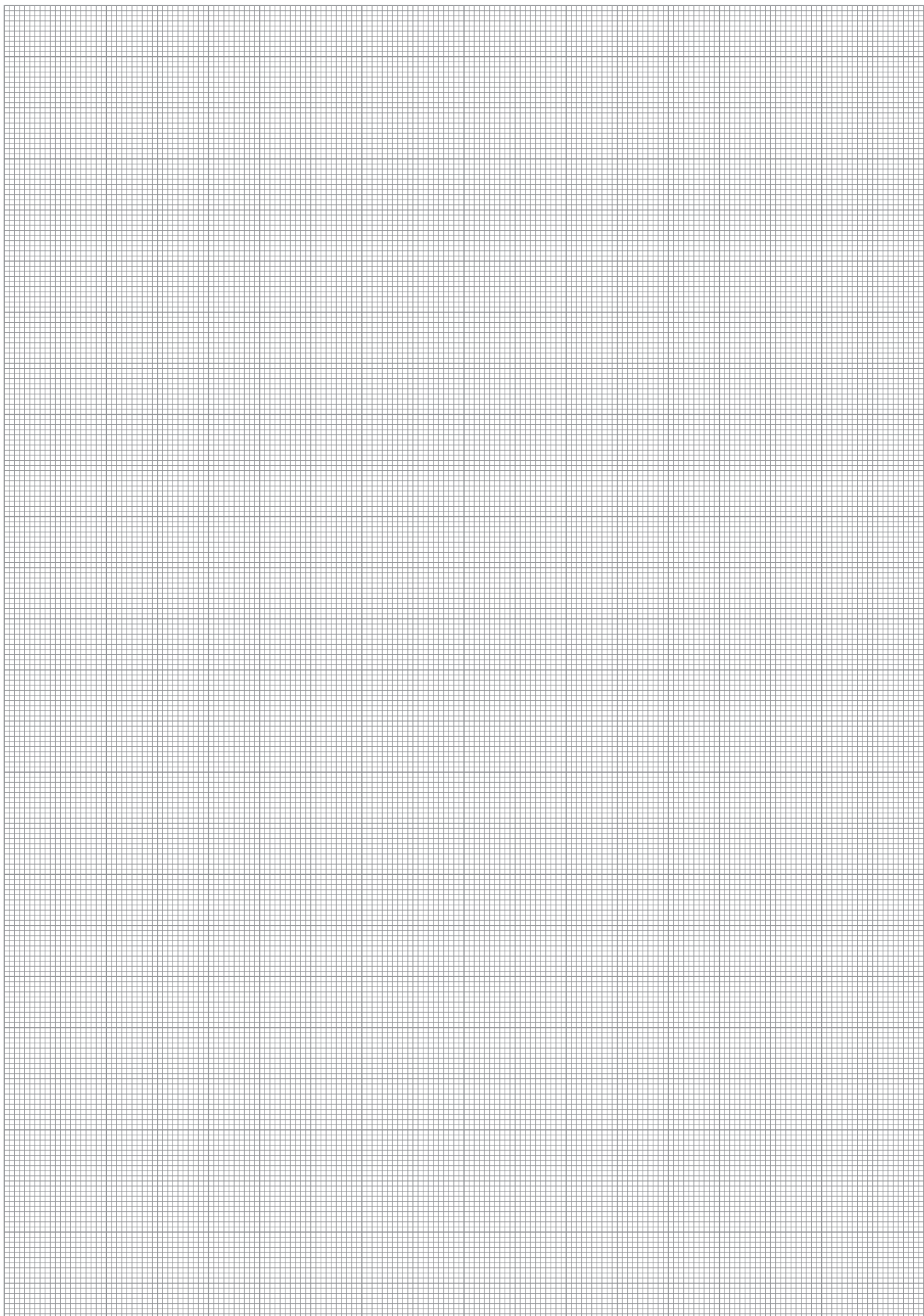





### Gripping force, I.D. gripping

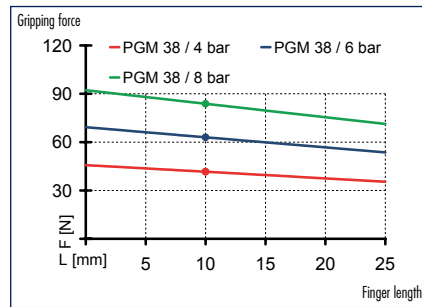

### Gripping force, O.D. gripping

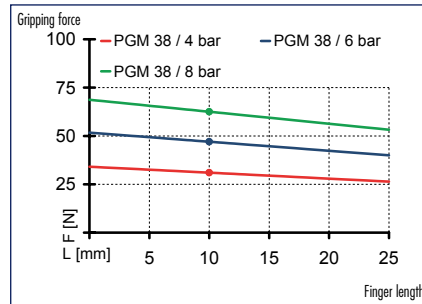

### Finger load

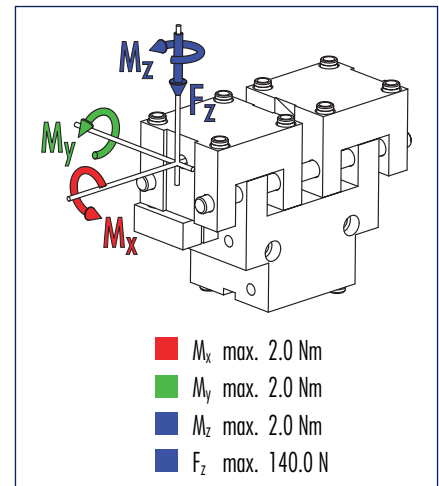

ⓘ Moments and forces apply per base jaw and may occur simultaneously.  $M_y$  may arise in addition to the moment generated by the gripping force itself. If the max. permitted finger weight is exceeded, it is imperative to throttle the air pressure so that the jaw movement occurs without any hitting or bouncing. Service life may reduce.

## Technical data

Description	PGM 38	
	ID	0302681
Stroke per finger	[mm]	3.0
Closing force	[N]	47.0
Opening force	[N]	63.0
Weight	[kg]	0.05
Recommended workpiece weight	[kg]	0.235
Air consumption per double stroke	[cm <sup>3</sup> ]	0.34
Nominal pressure	[bar]	6.0
Minimum pressure	[bar]	2.0
Maximum pressure	[bar]	8.0
Closing time	[s]	0.03
Opening time	[s]	0.03
Max. permitted finger length	[mm]	25.0
Max. permitted weight per finger	[kg]	0.017
IP class		30
Min. ambient temperature	[°C]	-10.0
Max. ambient temperature	[°C]	90.0
Repeat accuracy	[mm]	0.02

### Main views

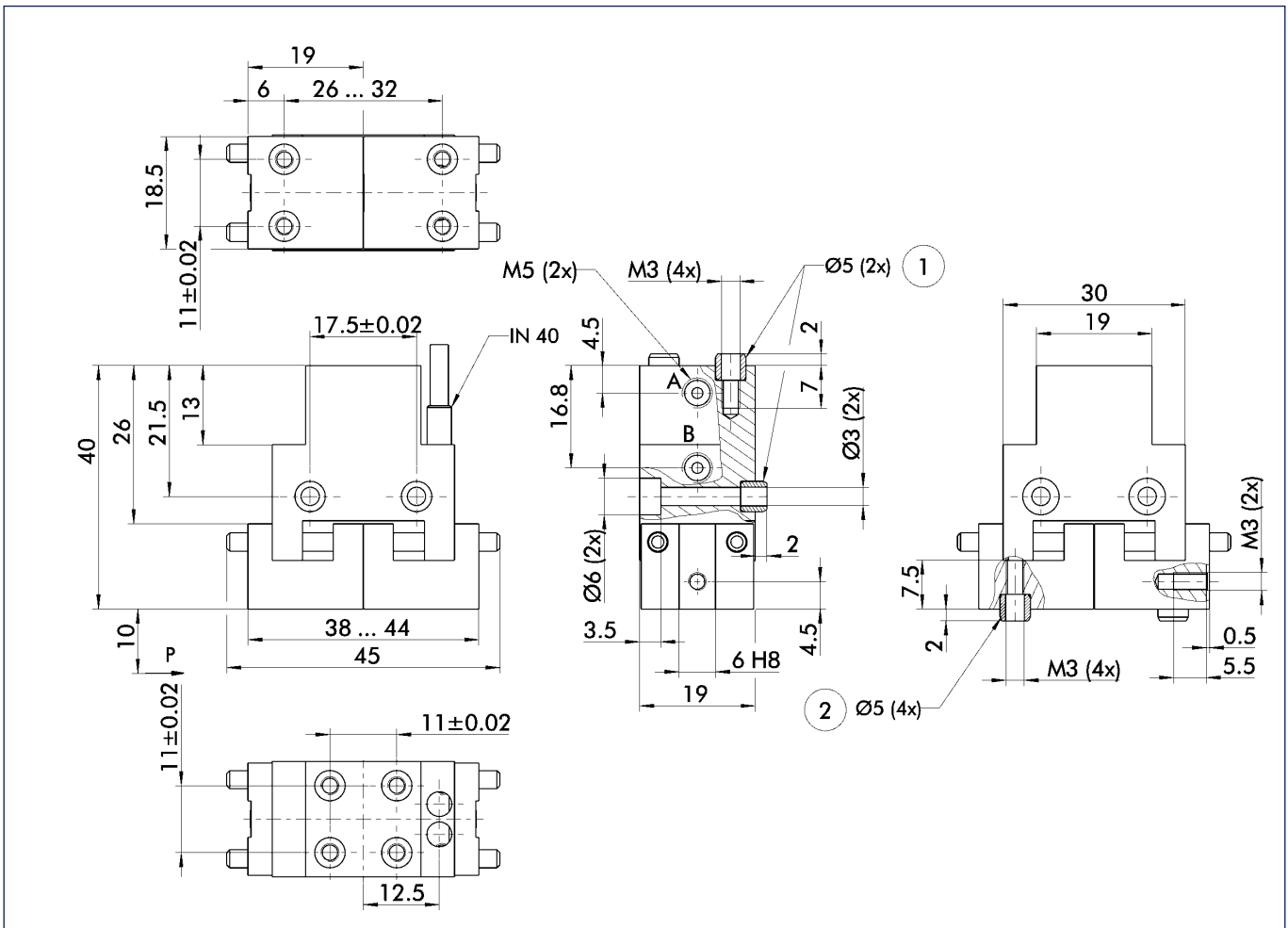

The drawing shows the gripper in the basic version with closed jaws, the dimensions do not include the options described below.

- A,a Main/direct connection, gripper opening
- B,b Main/direct connection, gripper closing
- ① Gripper connection
- ② Finger connection

① The SDV-P pressure maintenance valve can be used as a gripping force safety device (see „Accessories“ catalog section).

### Maximum permitted finger offset

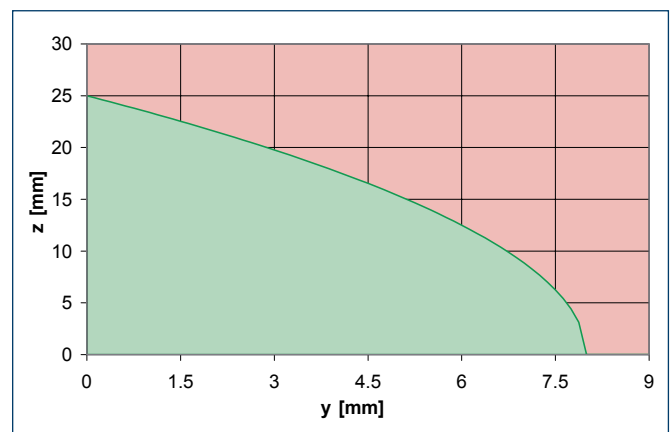
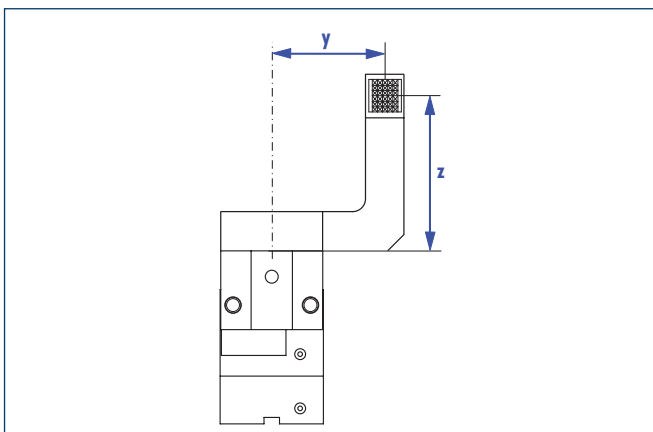

- Permitted range
- Non-permissible range

### Sensor system

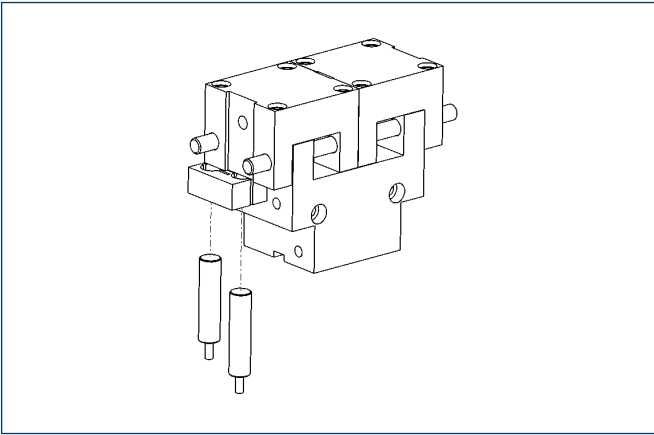

#### End position monitoring:

#### Inductive proximity switches, for direct mounting

Description	ID	Recommended product
IN 40-S-M12	0301574	
IN 40-S-M5-NPN	0301492	
IN 40-S-M5-PNP	0301491	
IN 40-S-M8	0301474	•
INK 40-S	0301555	

① Two sensors (NO contacts) are required for each gripper, plus extension cables as an option.

#### Extension cables for proximity switches/magnetic switches

Description	ID
KA BG05-L 3P-0300	0301652
KA BG08-L 3P-0300-PNP	0301622
KA BW05-L 3P-0300	0301650
KA BW08-L 3P-0300-PNP	0301594
KA BW08-L 3P-0500-PNP	0301502
KA BW12-L 3P-0300-PNP	0301503
KA BW12-L 3P-0500-PNP	0301507
KV BW08-SG08 3P-0030-PNP	0301495
KV BW08-SG08 3P-0100-PNP	0301496
KV BW08-SG08 3P-0200-PNP	0301497
KV BW12-SG12 3P-0030-PNP	0301595
KV BW12-SG12 3P-0100-PNP	0301596
KV BW12-SG12 3P-0200-PNP	0301597

① Please note the minimum permitted bending radii for the sensor cables, which are generally 35 mm.



You can find more detailed information and individual parts of the above-mentioned accessories in the „Accessories“ catalog section.

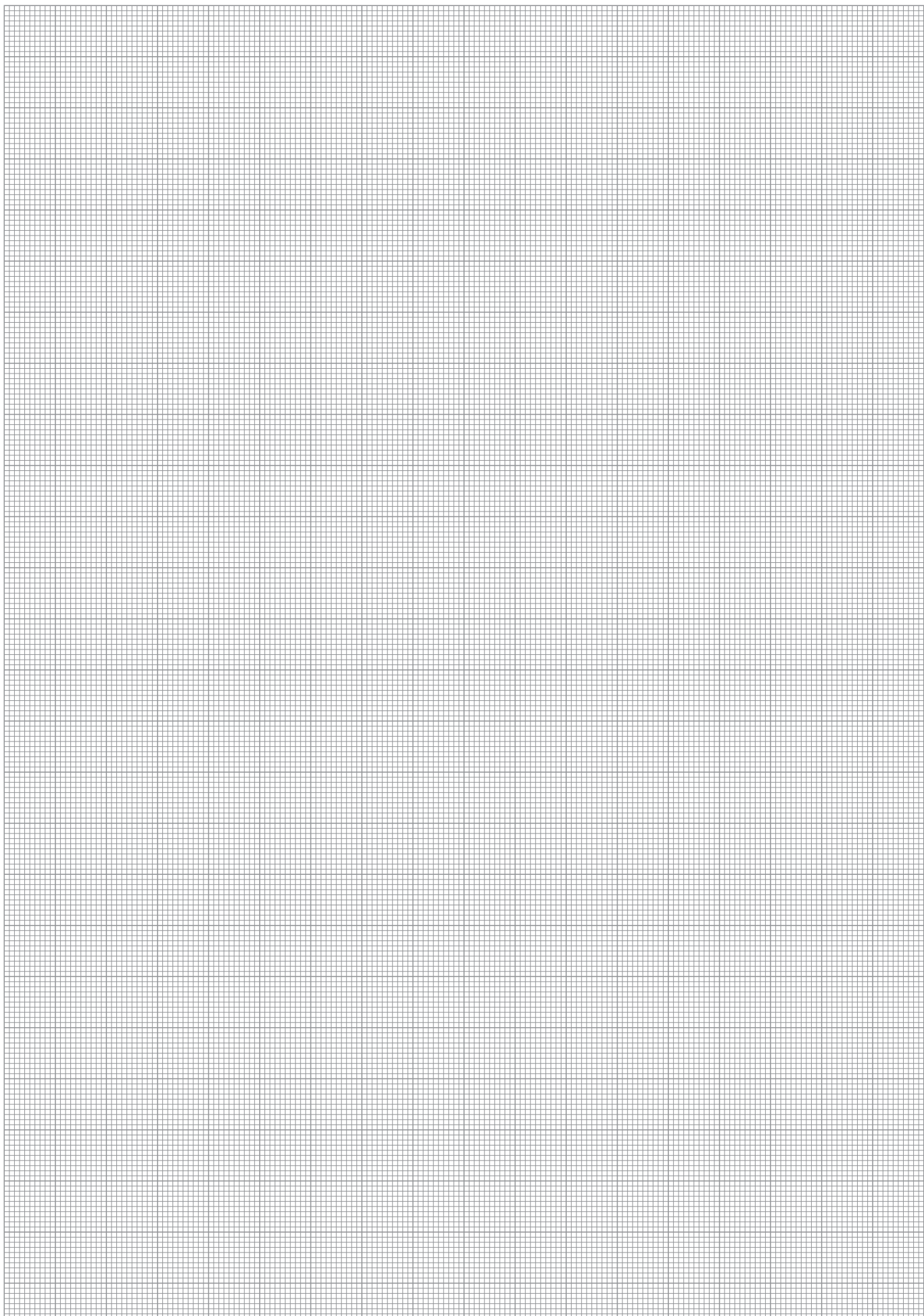



### Gripping force, I.D. gripping

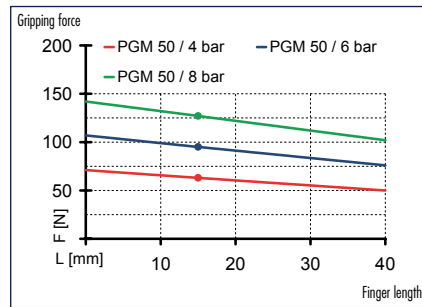

### Gripping force, O.D. gripping

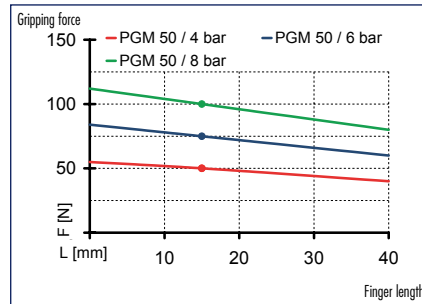

### Finger load

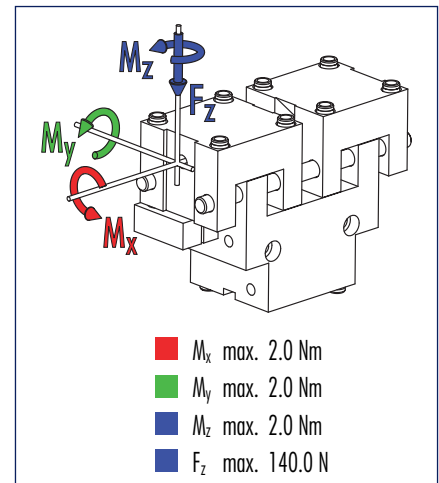

ⓘ Moments and forces apply per base jaw and may occur simultaneously.  $M_y$  may arise in addition to the moment generated by the gripping force itself. If the max. permitted finger weight is exceeded, it is imperative to throttle the air pressure so that the jaw movement occurs without any hitting or bouncing. Service life may reduce.

## Technical data

Description	PGM 50
ID	0302682
Stroke per finger	[mm] 4.0
Closing force	[N] 75.0
Opening force	[N] 95.0
Weight	[kg] 0.105
Recommended workpiece weight	[kg] 0.375
Air consumption per double stroke	[cm <sup>3</sup> ] 0.8
Nominal pressure	[bar] 6.0
Minimum pressure	[bar] 2.0
Maximum pressure	[bar] 8.0
Closing time	[s] 0.04
Opening time	[s] 0.04
Max. permitted finger length	[mm] 40.0
Max. permitted weight per finger	[kg] 0.035
IP class	30
Min. ambient temperature	[°C] -10.0
Max. ambient temperature	[°C] 90.0
Repeat accuracy	[mm] 0.02

### Main views

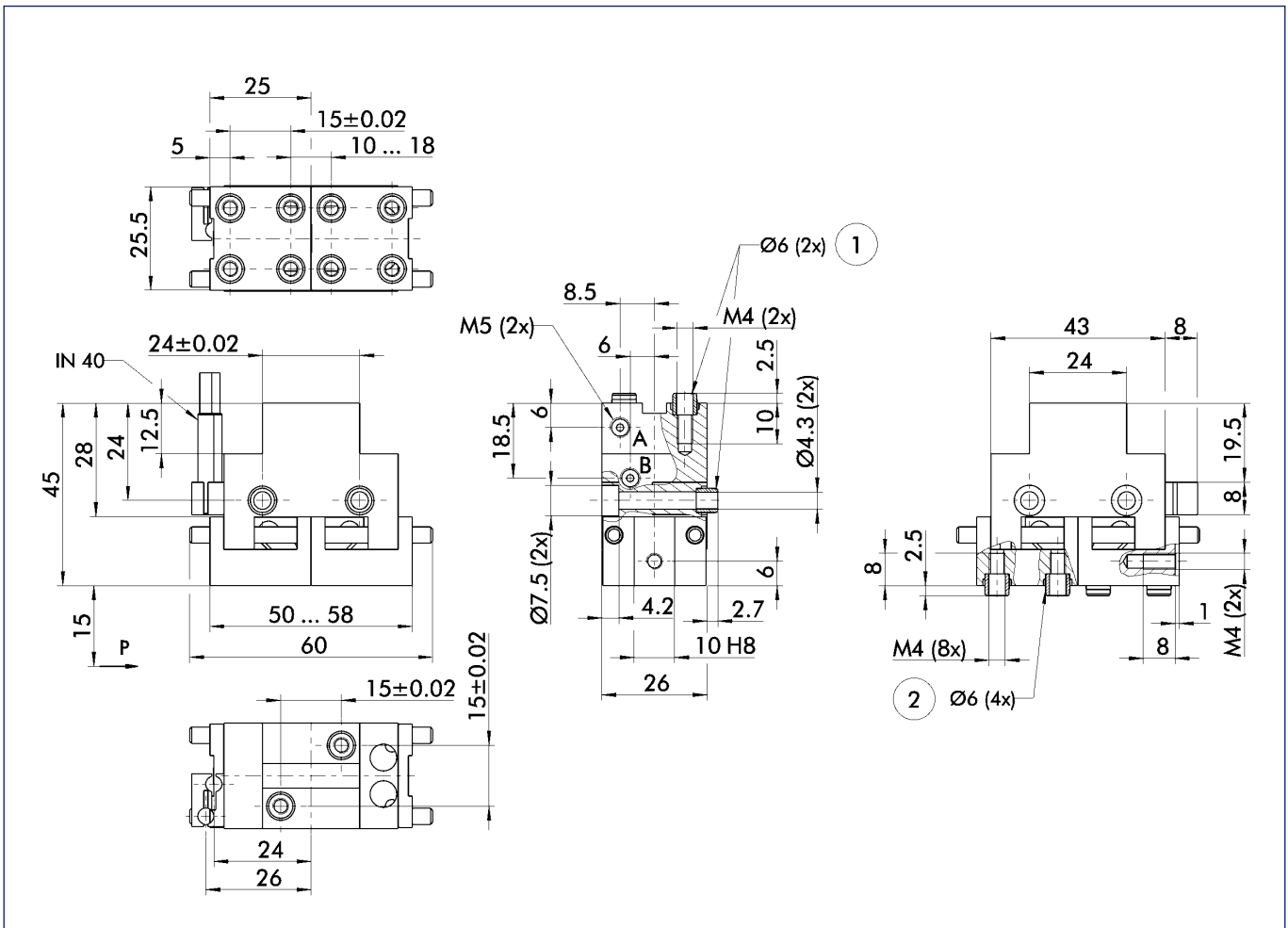

The drawing shows the gripper in the basic version with closed jaws, the dimensions do not include the options described below.

- A,a Main/direct connection, gripper opening
- B,b Main/direct connection, gripper closing
- ① Gripper connection
- ② Finger connection

① The SDV-P pressure maintenance valve can be used as a gripping force safety device (see „Accessories“ catalog section).

### Maximum permitted finger offset

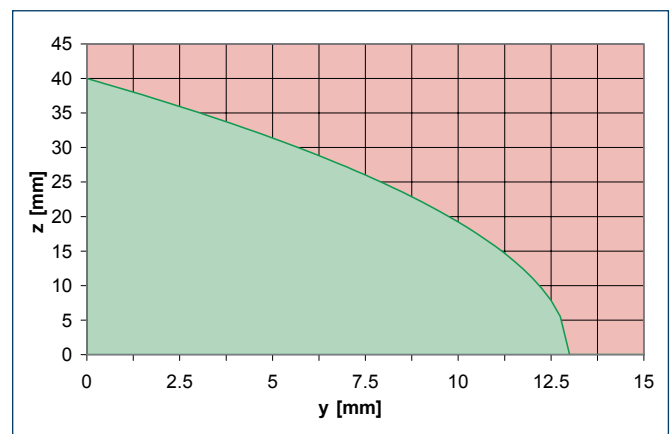
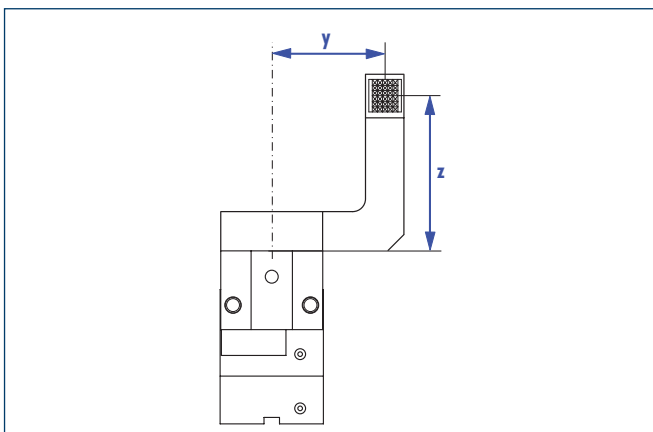

- Permitted range
- Non-permissible range

### Sensor system

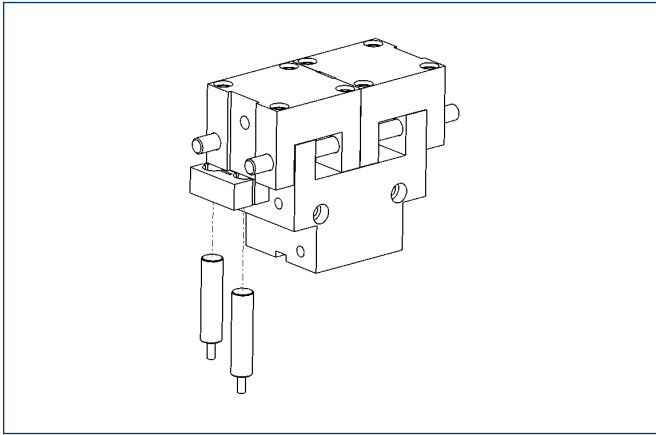

#### End position monitoring:

#### Inductive proximity switches, for direct mounting

Description	ID	Recommended product
IN 40-S-M12	0301574	
IN 40-S-M5-NPN	0301492	
IN 40-S-M5-PNP	0301491	
IN 40-S-M8	0301474	•
INK 40-S	0301555	

① Two sensors (NO contacts) are required for each gripper, plus extension cables as an option.

#### Extension cables for proximity switches/magnetic switches

Description	ID
KA BG05-L 3P-0300	0301652
KA BG08-L 3P-0300-PNP	0301622
KA BW05-L 3P-0300	0301650
KA BW08-L 3P-0300-PNP	0301594
KA BW08-L 3P-0500-PNP	0301502
KA BW12-L 3P-0300-PNP	0301503
KA BW12-L 3P-0500-PNP	0301507
KV BW08-SG08 3P-0030-PNP	0301495
KV BW08-SG08 3P-0100-PNP	0301496
KV BW08-SG08 3P-0200-PNP	0301497
KV BW12-SG12 3P-0030-PNP	0301595
KV BW12-SG12 3P-0100-PNP	0301596
KV BW12-SG12 3P-0200-PNP	0301597

① Please note the minimum permitted bending radii for the sensor cables, which are generally 35 mm.



You can find more detailed information and individual parts of the above-mentioned accessories in the „Accessories“ catalog section.

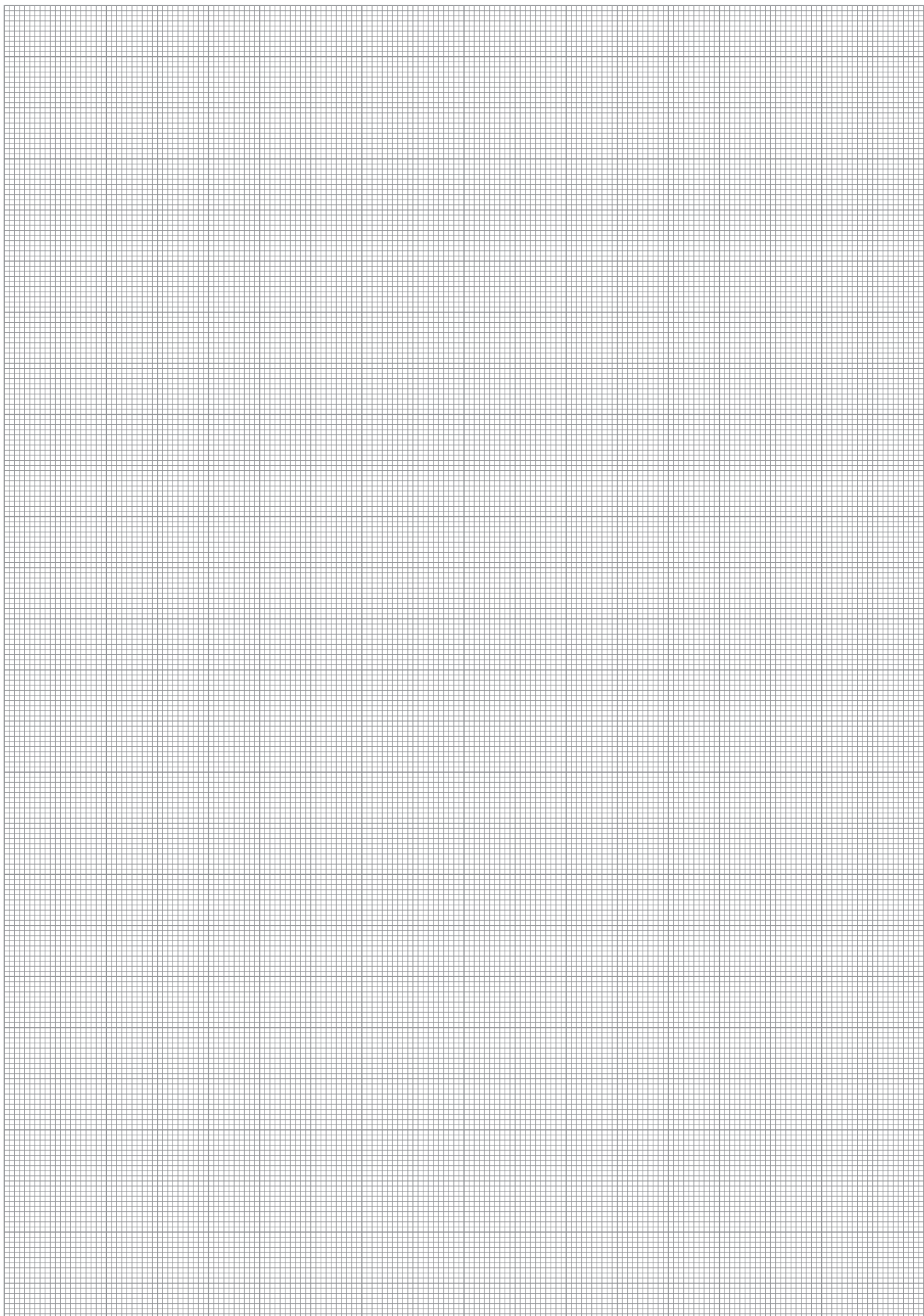





### Gripping force, I.D. gripping

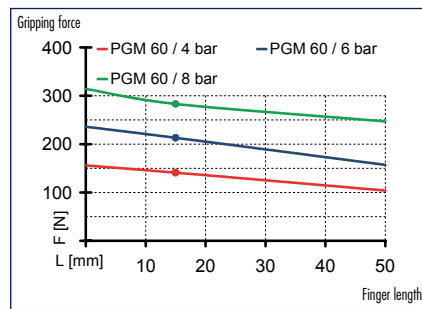

### Gripping force, O.D. gripping

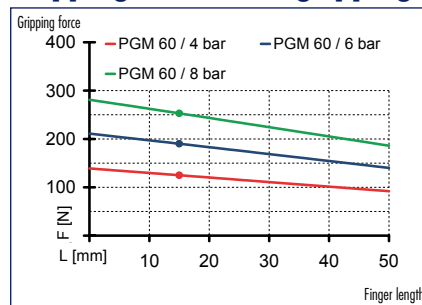

### Finger load

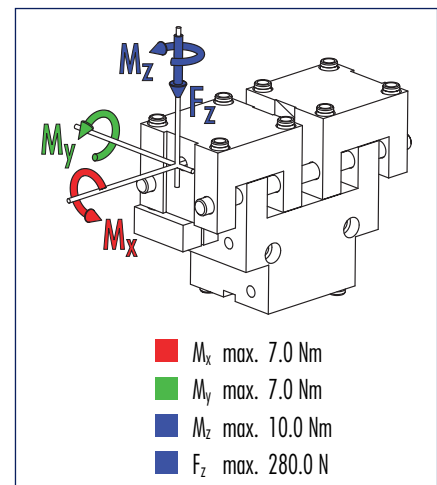

ⓘ Moments and forces apply per base jaw and may occur simultaneously.  $M_y$  may arise in addition to the moment generated by the gripping force itself. If the max. permitted finger weight is exceeded, it is imperative to throttle the air pressure so that the jaw movement occurs without any hitting or bouncing. Service life may reduce.

## Technical data

Description	PGM 60	
	ID	0302683
Stroke per finger	[mm]	5.0
Closing force	[N]	190.0
Opening force	[N]	210.0
Weight	[kg]	0.21
Recommended workpiece weight	[kg]	0.95
Air consumption per double stroke	[cm <sup>3</sup> ]	2.5
Nominal pressure	[bar]	6.0
Minimum pressure	[bar]	2.0
Maximum pressure	[bar]	8.0
Closing time	[s]	0.05
Opening time	[s]	0.05
Max. permitted finger length	[mm]	50.0
Max. permitted weight per finger	[kg]	0.07
IP class		30
Min. ambient temperature	[°C]	-10.0
Max. ambient temperature	[°C]	90.0
Repeat accuracy	[mm]	0.02

### Main views

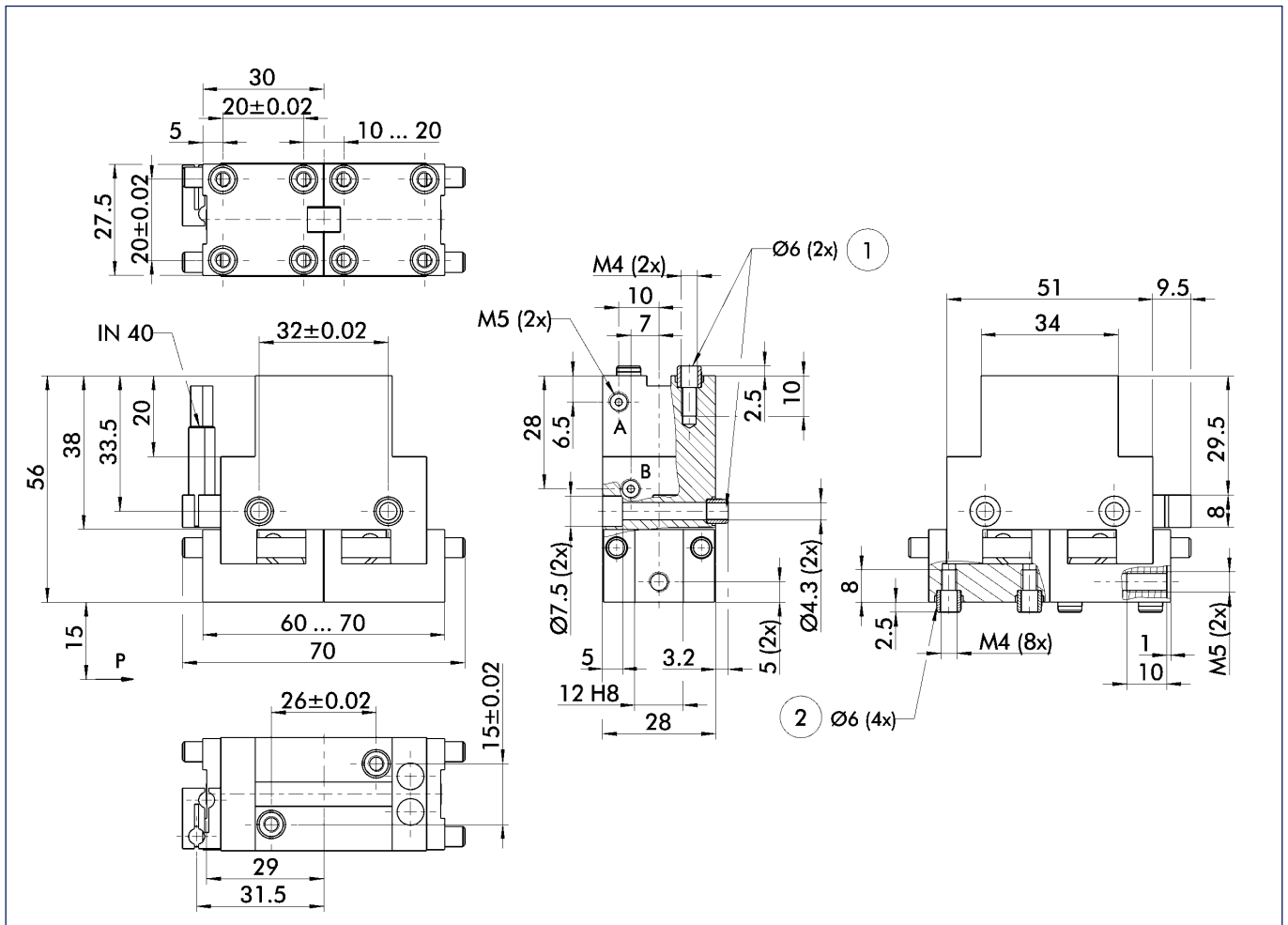

The drawing shows the gripper in the basic version with closed jaws, the dimensions do not include the options described below.

- A,a Main/direct connection, gripper opening
- B,b Main/direct connection, gripper closing
- ① Gripper connection
- ② Finger connection

① The SDV-P pressure maintenance valve can be used as a gripping force safety device (see „Accessories“ catalog section).

### Maximum permitted finger offset

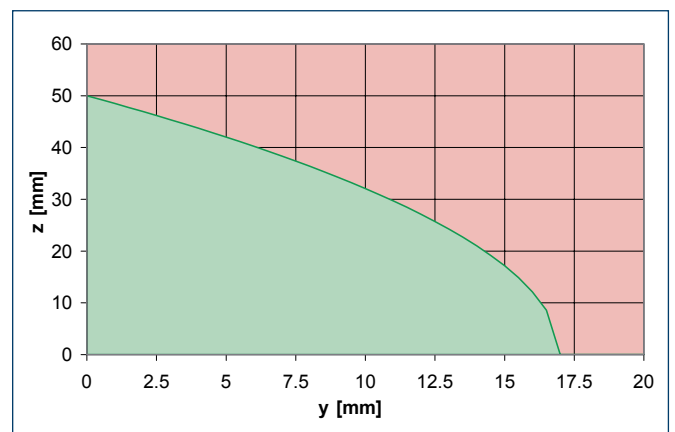
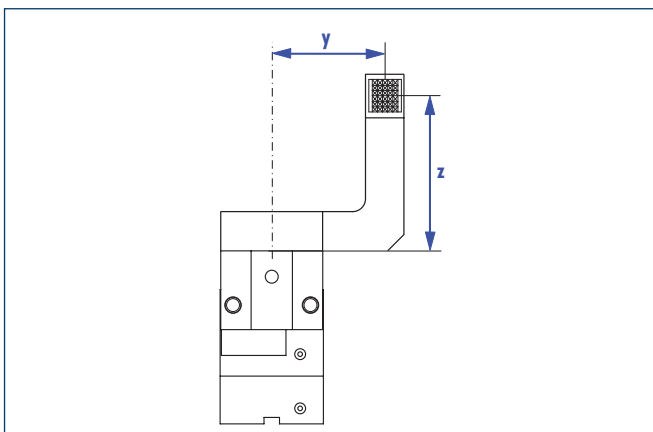

- Permitted range
- Non-permissible range

### Sensor system

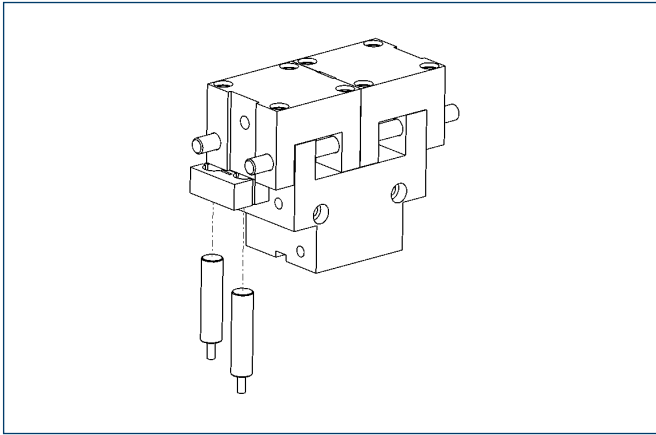

#### End position monitoring:

#### Inductive proximity switches, for direct mounting

Description	ID	Recommended product
IN 40-S-M12	0301574	
IN 40-S-M5-NPN	0301492	
IN 40-S-M5-PNP	0301491	
IN 40-S-M8	0301474	•
INK 40-S	0301555	

① Two sensors (NO contacts) are required for each gripper, plus extension cables as an option.

#### Extension cables for proximity switches/magnetic switches

Description	ID
KA BG05-L 3P-0300	0301652
KA BG08-L 3P-0300-PNP	0301622
KA BW05-L 3P-0300	0301650
KA BW08-L 3P-0300-PNP	0301594
KA BW08-L 3P-0500-PNP	0301502
KA BW12-L 3P-0300-PNP	0301503
KA BW12-L 3P-0500-PNP	0301507
KV BW08-SG08 3P-0030-PNP	0301495
KV BW08-SG08 3P-0100-PNP	0301496
KV BW08-SG08 3P-0200-PNP	0301497
KV BW12-SG12 3P-0030-PNP	0301595
KV BW12-SG12 3P-0100-PNP	0301596
KV BW12-SG12 3P-0200-PNP	0301597

① Please note the minimum permitted bending radii for the sensor cables, which are generally 35 mm.



You can find more detailed information and individual parts of the above-mentioned accessories in the „Accessories“ catalog section.

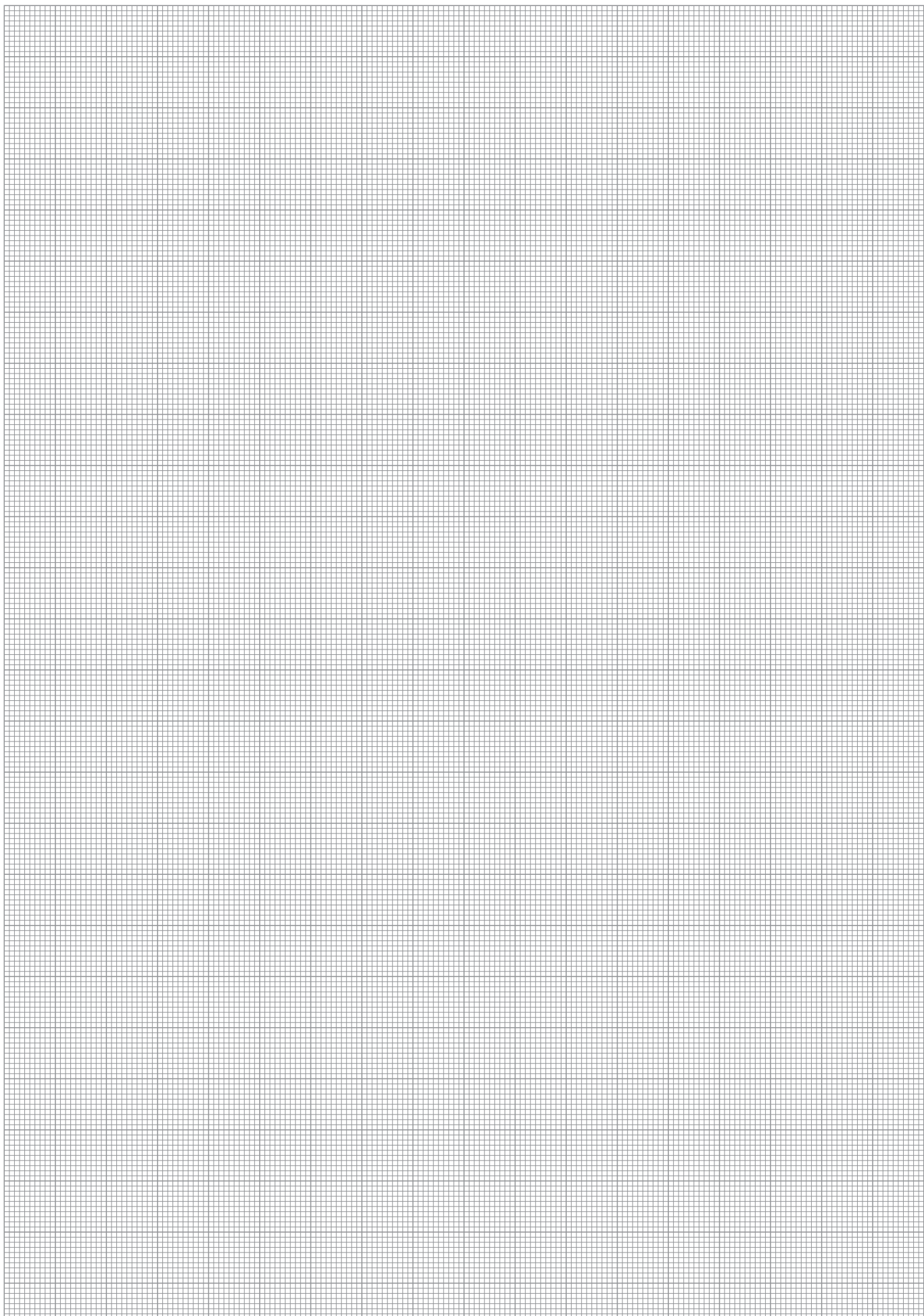



### Gripping force, I.D. gripping

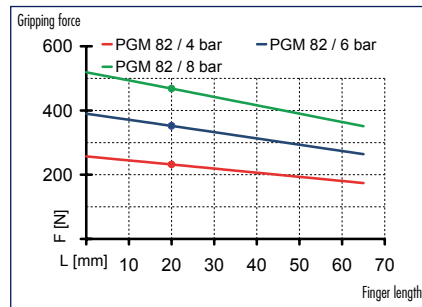

### Gripping force, O.D. gripping

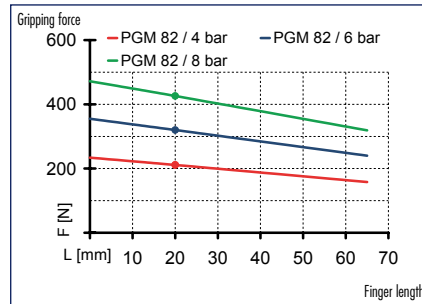

### Finger load

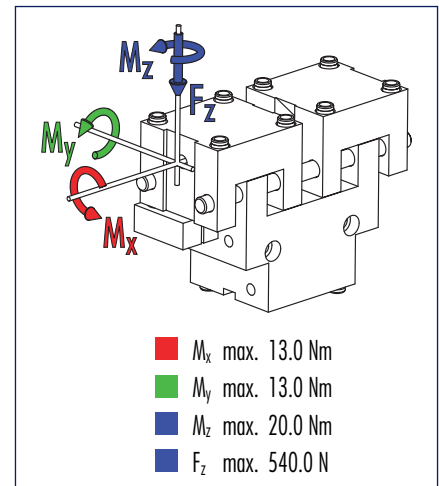

ⓘ Moments and forces apply per base jaw and may occur simultaneously.  $M_y$  may arise in addition to the moment generated by the gripping force itself. If the max. permitted finger weight is exceeded, it is imperative to throttle the air pressure so that the jaw movement occurs without any hitting or bouncing. Service life may reduce.

## Technical data

Description	PGM 82
	<b>0302684</b>
Stroke per finger	[mm] 10.0
Closing force	[N] 320.0
Opening force	[N] 350.0
Weight	[kg] 0.6
Recommended workpiece weight	[kg] 1.6
Air consumption per double stroke	[cm <sup>3</sup> ] 8.0
Nominal pressure	[bar] 6.0
Minimum pressure	[bar] 2.0
Maximum pressure	[bar] 8.0
Closing time	[s] 0.07
Opening time	[s] 0.07
Max. permitted finger length	[mm] 65.0
Max. permitted weight per finger	[kg] 0.17
IP class	30
Min. ambient temperature	[°C] -10.0
Max. ambient temperature	[°C] 90.0
Repeat accuracy	[mm] 0.03

### Main views

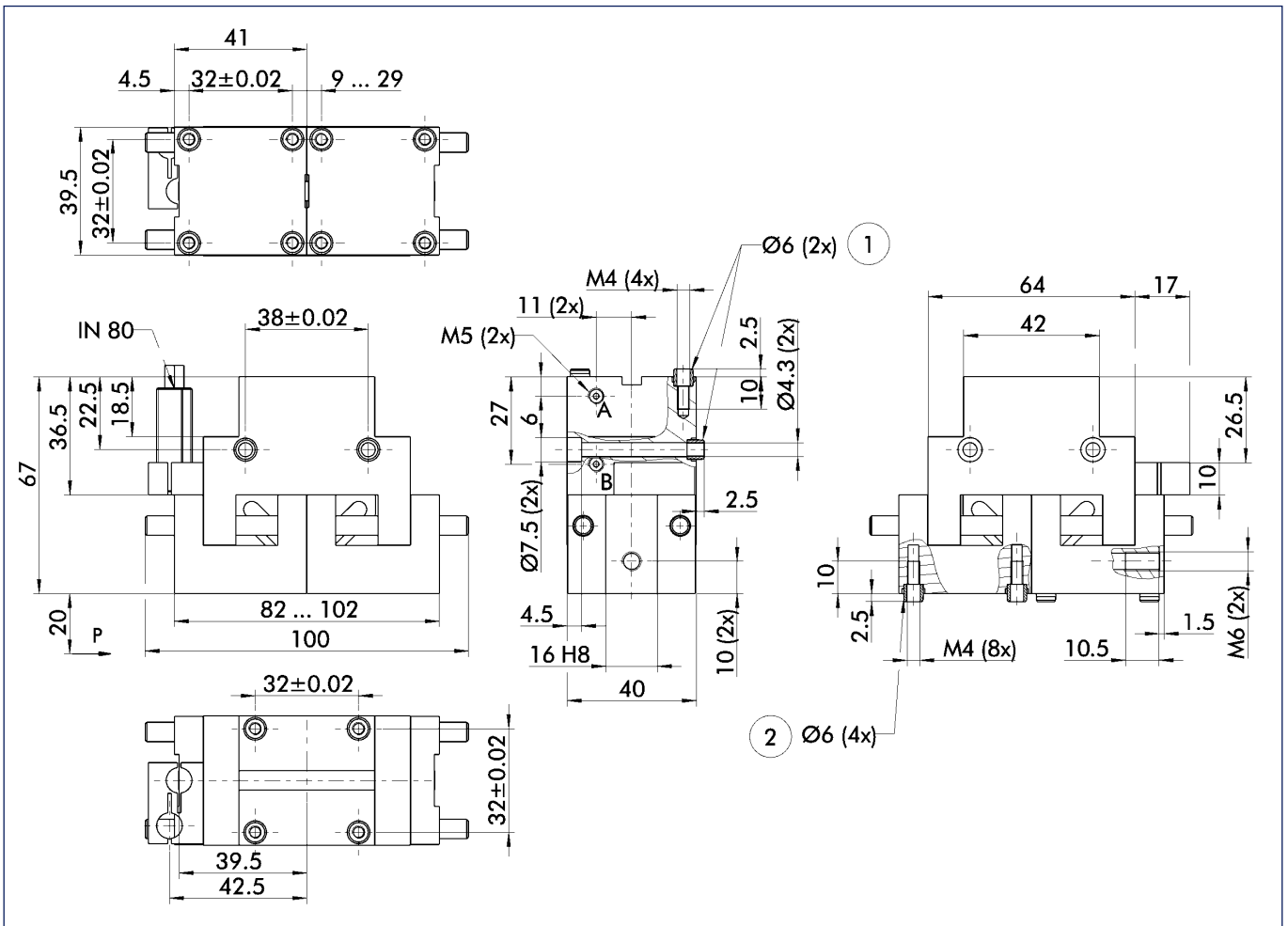

The drawing shows the gripper in the basic version with closed jaws, the dimensions do not include the options described below.

① The SDV-P pressure maintenance valve can be used as a gripping force safety device (see „Accessories“ catalog section).

- A,a Main/direct connection, gripper opening
- B,b Main/direct connection, gripper closing
- ① Gripper connection
- ② Finger connection

### Maximum permitted finger offset

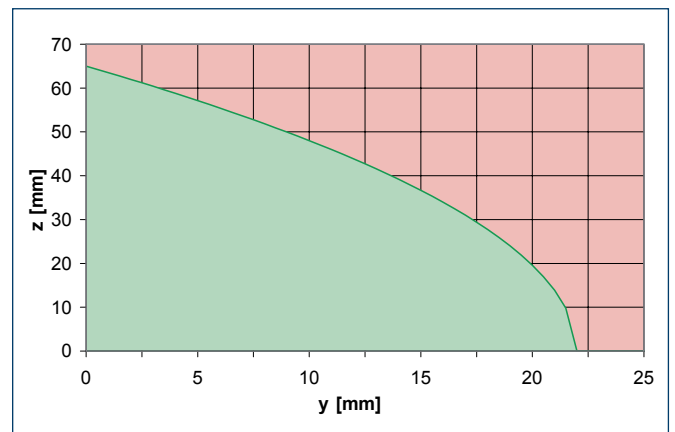
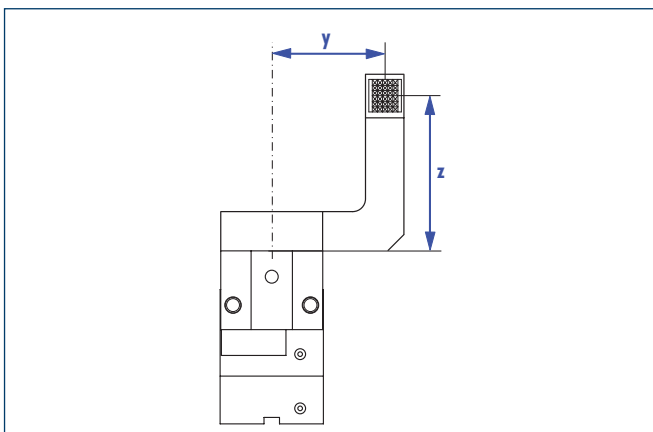

- Permitted range
- Non-permissible range

### Sensor system

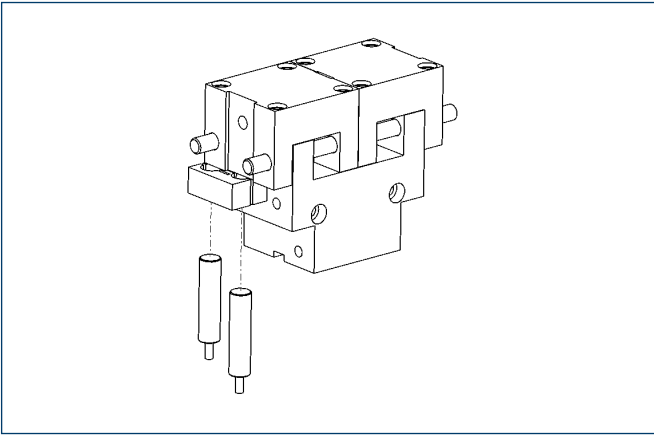

#### End position monitoring:

#### Inductive proximity switches, for direct mounting

Description	ID	Recommended product
IN 80-S-M12	0301578	
IN 80-S-M8	0301478	•
INK 80-S	0301550	

① Two sensors (NO contacts) are required for each gripper, plus extension cables as an option.

#### Extension cables for proximity switches/magnetic switches

Description	ID
KA BG08-L 3P-0300-PNP	0301622
KA BW08-L 3P-0300-PNP	0301594
KA BW08-L 3P-0500-PNP	0301502
KA BW12-L 3P-0300-PNP	0301503
KA BW12-L 3P-0500-PNP	0301507
KV BW08-SG08 3P-0030-PNP	0301495
KV BW08-SG08 3P-0100-PNP	0301496
KV BW08-SG08 3P-0200-PNP	0301497
KV BW12-SG12 3P-0030-PNP	0301595
KV BW12-SG12 3P-0100-PNP	0301596
KV BW12-SG12 3P-0200-PNP	0301597

① Please note the minimum permitted bending radii for the sensor cables, which are generally 35 mm.



You can find more detailed information and individual parts of the above-mentioned accessories in the „Accessories“ catalog section.

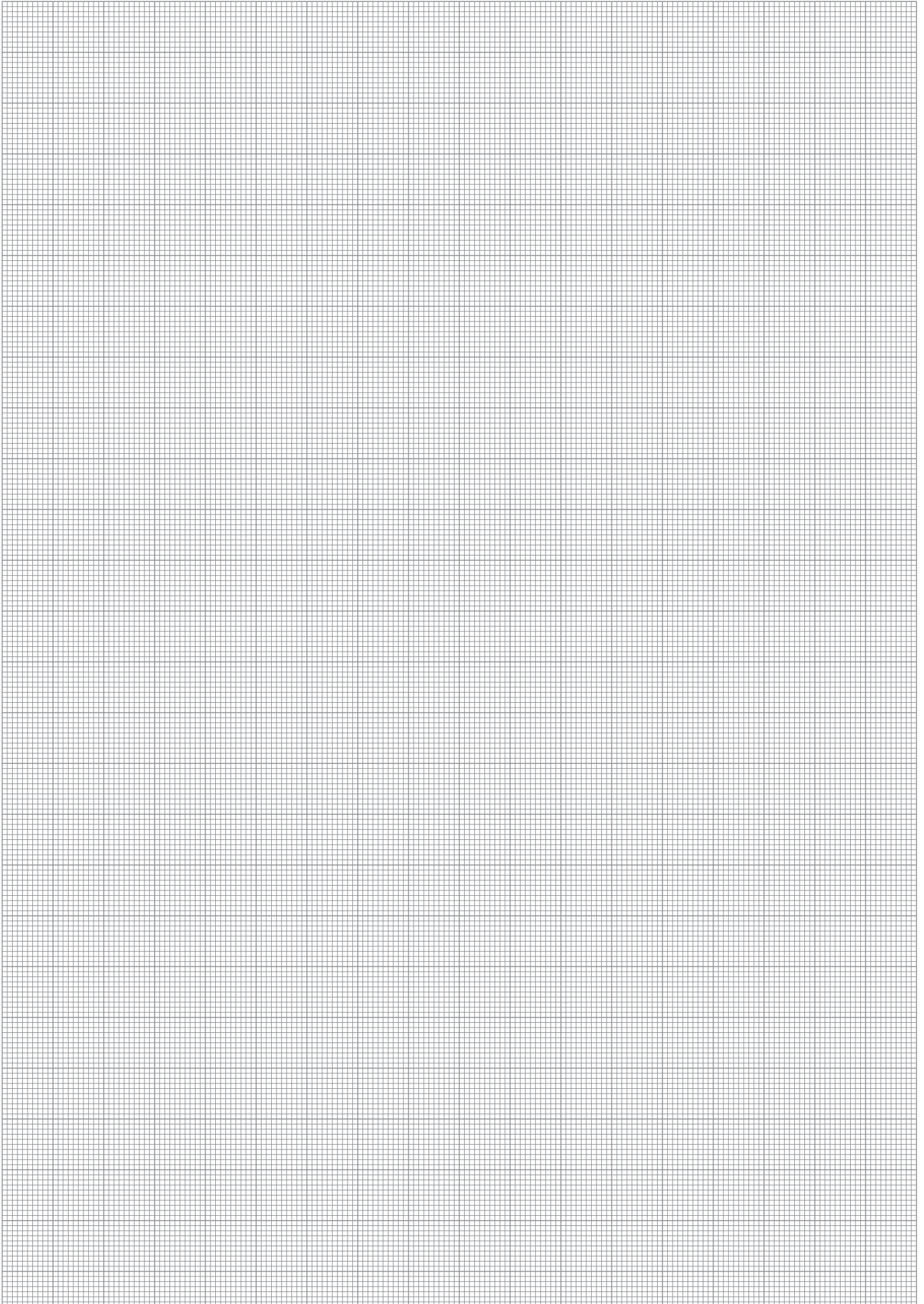





### Gripping force, I.D. gripping

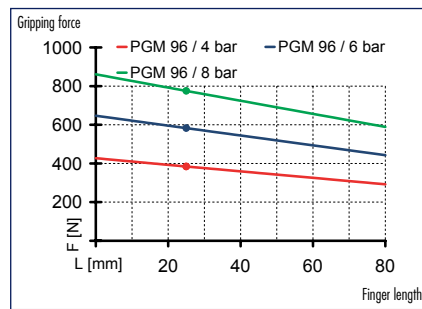

### Gripping force, O.D. gripping

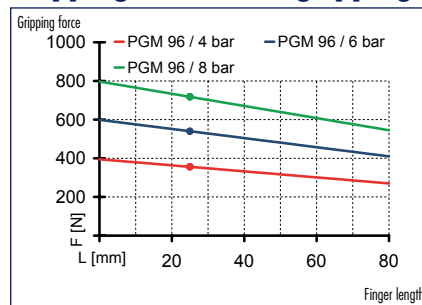

### Finger load

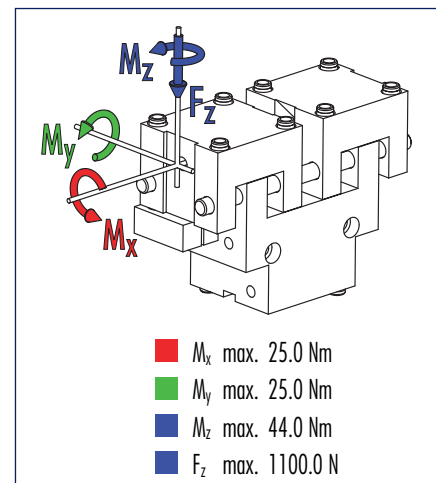

ⓘ Moments and forces apply per base jaw and may occur simultaneously.  $M_y$  may arise in addition to the moment generated by the gripping force itself. If the max. permitted finger weight is exceeded, it is imperative to throttle the air pressure so that the jaw movement occurs without any hitting or bouncing. Service life may reduce.

## Technical data

Description	PGM 96
ID	0302685
Stroke per finger	[mm] 12.0
Closing force	[N] 540.0
Opening force	[N] 580.0
Weight	[kg] 0.84
Recommended workpiece weight	[kg] 2.7
Air consumption per double stroke	[cm <sup>3</sup> ] 15.1
Nominal pressure	[bar] 6.0
Minimum pressure	[bar] 2.0
Maximum pressure	[bar] 8.0
Closing time	[s] 0.08
Opening time	[s] 0.08
Max. permitted finger length	[mm] 80.0
Max. permitted weight per finger	[kg] 0.28
IP class	30
Min. ambient temperature	[°C] -10.0
Max. ambient temperature	[°C] 90.0
Repeat accuracy	[mm] 0.03

### Main views

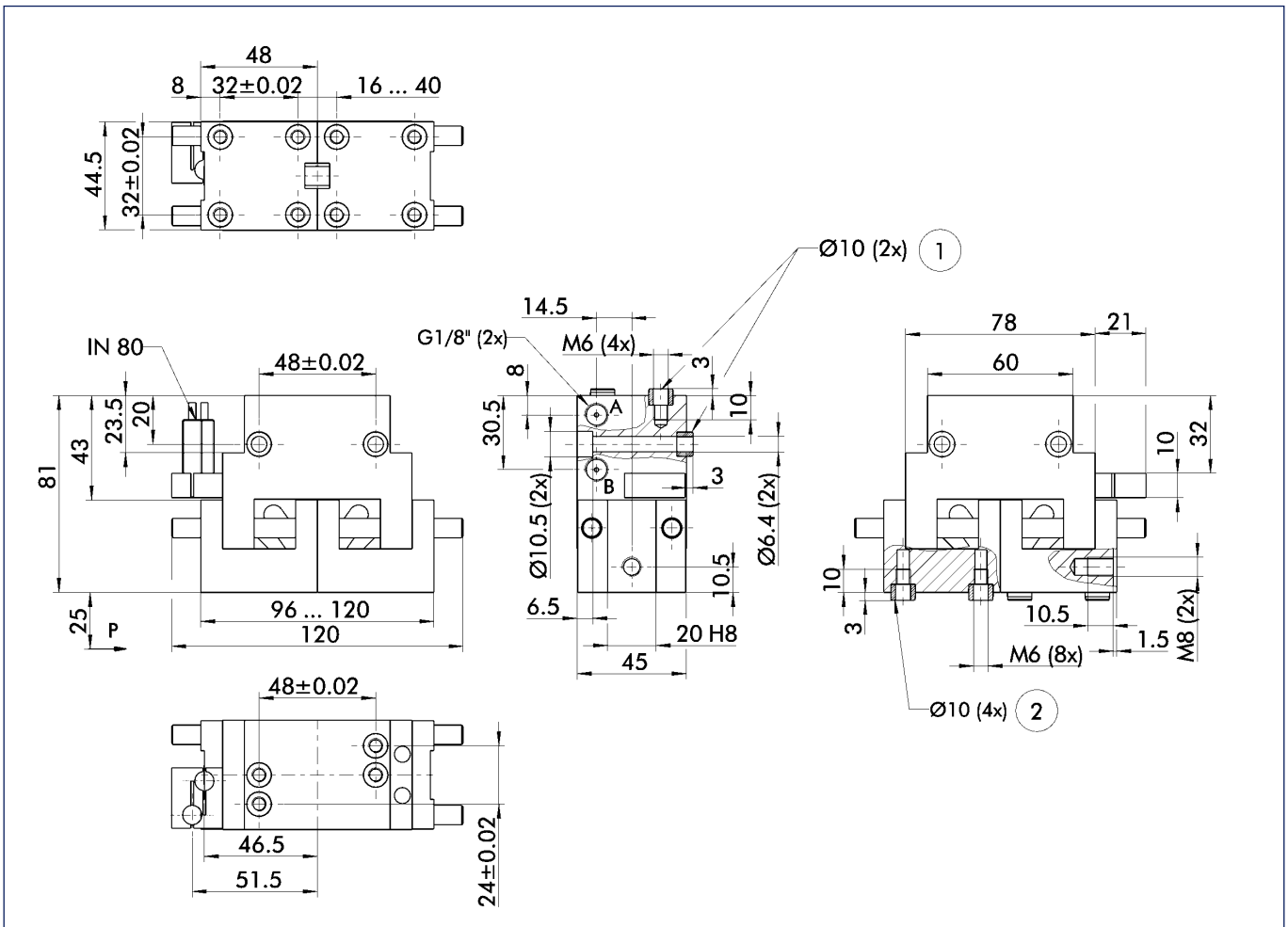

The drawing shows the gripper in the basic version with closed jaws, the dimensions do not include the options described below.

- A,a Main/direct connection, gripper opening
- B,b Main/direct connection, gripper closing
- ① Gripper connection
- ② Finger connection

① The SDV-P pressure maintenance valve can be used as a gripping force safety device (see „Accessories“ catalog section).

### Maximum permitted finger offset

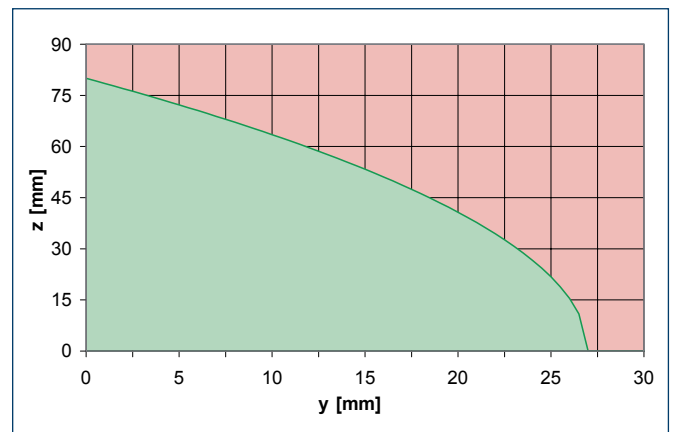
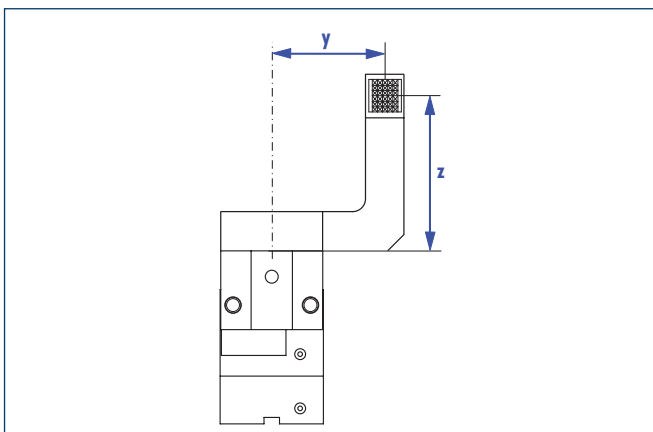

- Permitted range
- Non-permissible range

### Sensor system

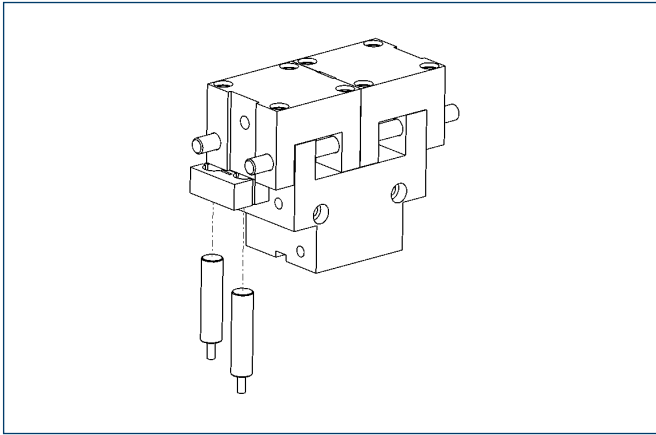

#### End position monitoring:

#### Inductive proximity switches, for direct mounting

Description	ID	Recommended product
IN 80-S-M12	0301578	
IN 80-S-M8	0301478	•
INK 80-S	0301550	

① Two sensors (NO contacts) are required for each gripper, plus extension cables as an option.

#### Extension cables for proximity switches/magnetic switches

Description	ID
KA BG08-L 3P-0300-PNP	0301622
KA BW08-L 3P-0300-PNP	0301594
KA BW08-L 3P-0500-PNP	0301502
KA BW12-L 3P-0300-PNP	0301503
KA BW12-L 3P-0500-PNP	0301507
KV BW08-SG08 3P-0030-PNP	0301495
KV BW08-SG08 3P-0100-PNP	0301496
KV BW08-SG08 3P-0200-PNP	0301497
KV BW12-SG12 3P-0030-PNP	0301595
KV BW12-SG12 3P-0100-PNP	0301596
KV BW12-SG12 3P-0200-PNP	0301597

① Please note the minimum permitted bending radii for the sensor cables, which are generally 35 mm.



You can find more detailed information and individual parts of the above-mentioned accessories in the „Accessories“ catalog section.

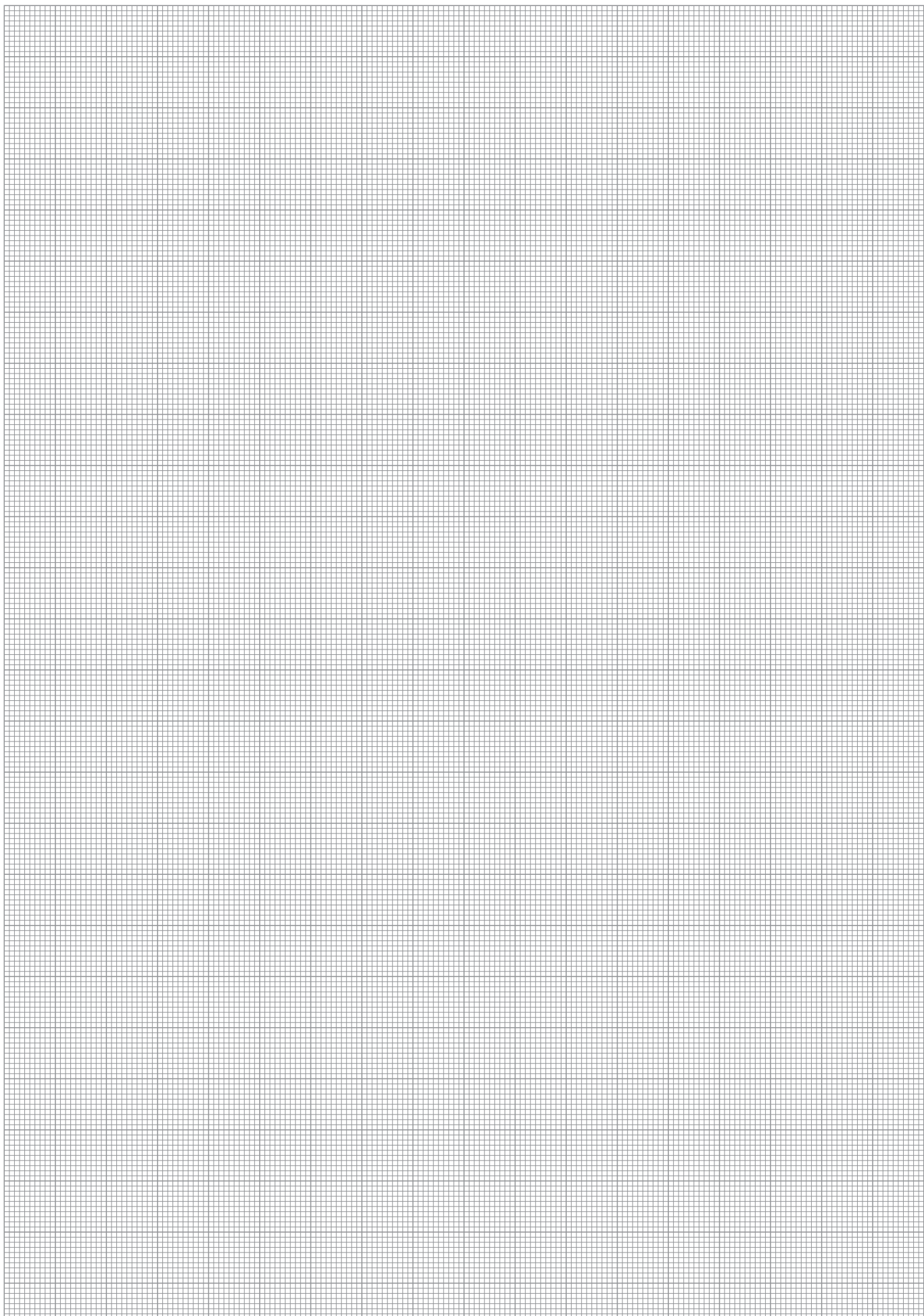

# PGM 120

Pneumatic · 2-Finger Parallel Gripper · **Universal Gripper**

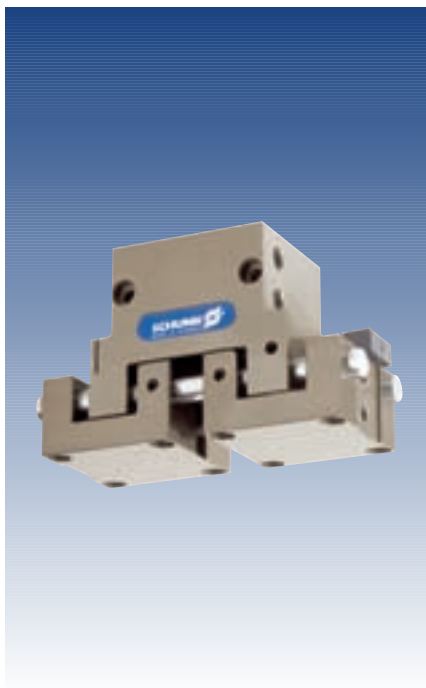

## Gripping force, I.D. gripping

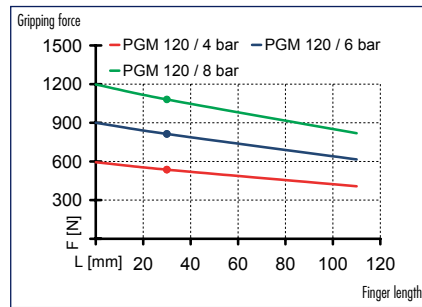

## Gripping force, O.D. gripping

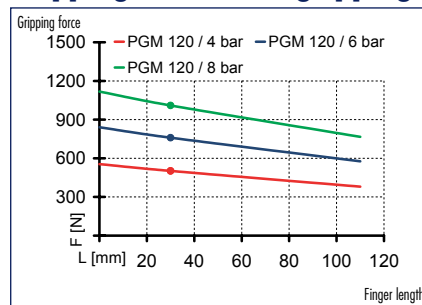

## Finger load

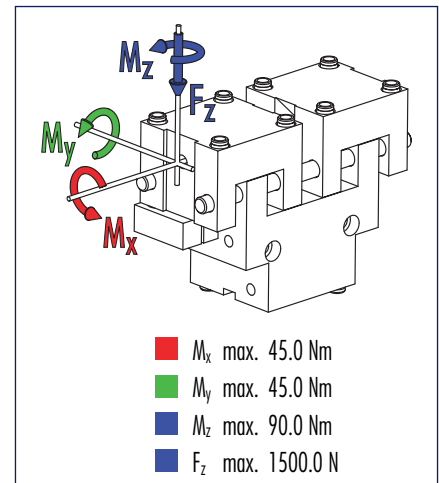

ⓘ Moments and forces apply per base jaw and may occur simultaneously.  $M_y$  may arise in addition to the moment generated by the gripping force itself. If the max. permitted finger weight is exceeded, it is imperative to throttle the air pressure so that the jaw movement occurs without any hitting or bouncing. Service life may reduce.

## Technical data

Description	PGM 120	
	ID	0302686
Stroke per finger	[mm]	12.0
Closing force	[N]	760.0
Opening force	[N]	810.0
Weight	[kg]	1.26
Recommended workpiece weight	[kg]	3.8
Air consumption per double stroke	[cm <sup>3</sup> ]	23.6
Nominal pressure	[bar]	6.0
Minimum pressure	[bar]	2.0
Maximum pressure	[bar]	8.0
Closing time	[s]	0.1
Opening time	[s]	0.1
Max. permitted finger length	[mm]	110.0
Max. permitted weight per finger	[kg]	0.58
IP class		30
Min. ambient temperature	[°C]	-10.0
Max. ambient temperature	[°C]	90.0
Repeat accuracy	[mm]	0.03

### Main views

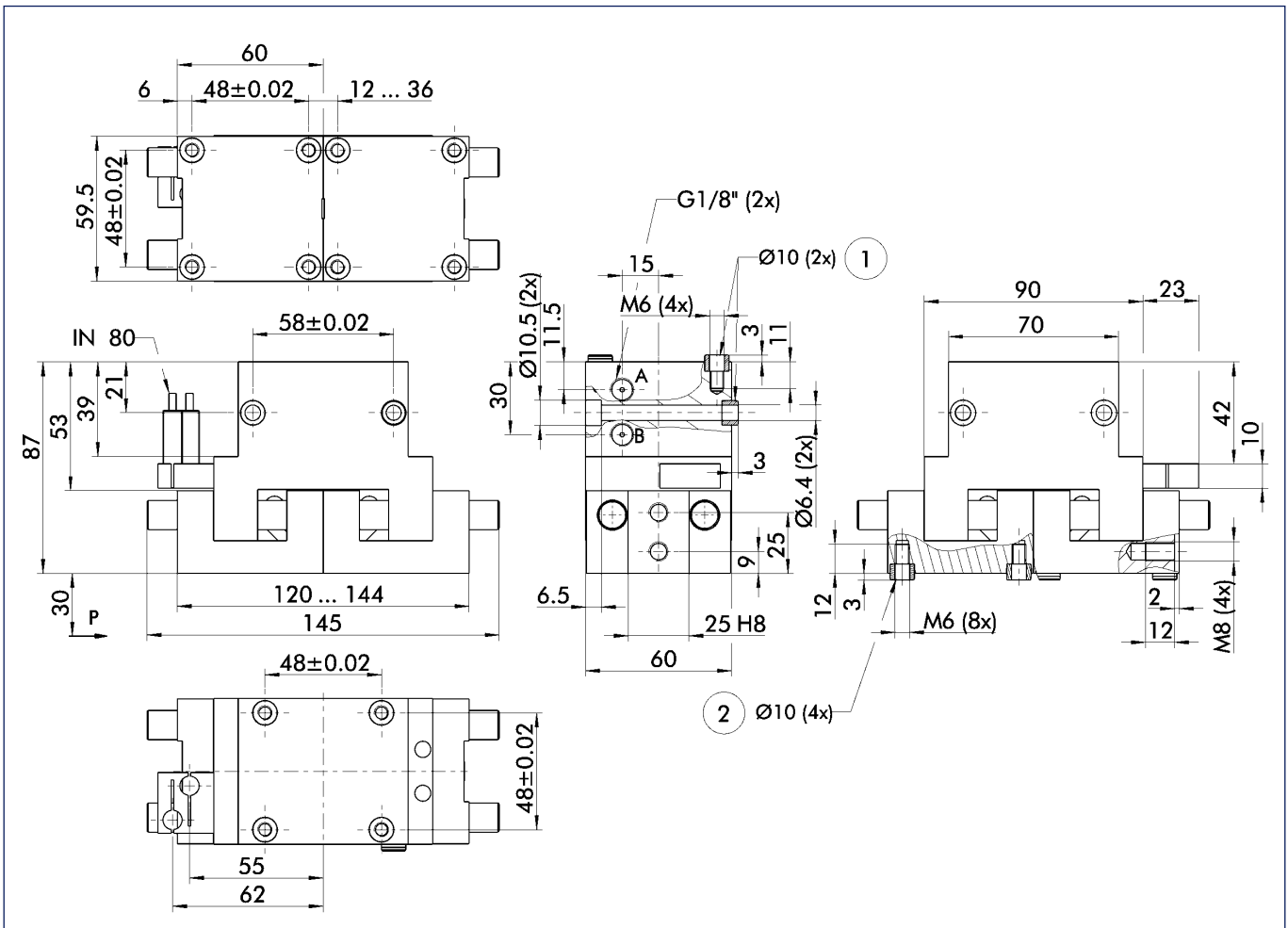

The drawing shows the gripper in the basic version with closed jaws, the dimensions do not include the options described below.

- A,a Main/direct connection, gripper opening
- B,b Main/direct connection, gripper closing
- ① Gripper connection
- ② Finger connection

① The SDV-P pressure maintenance valve can be used as a gripping force safety device (see „Accessories“ catalog section).

### Maximum permitted finger offset

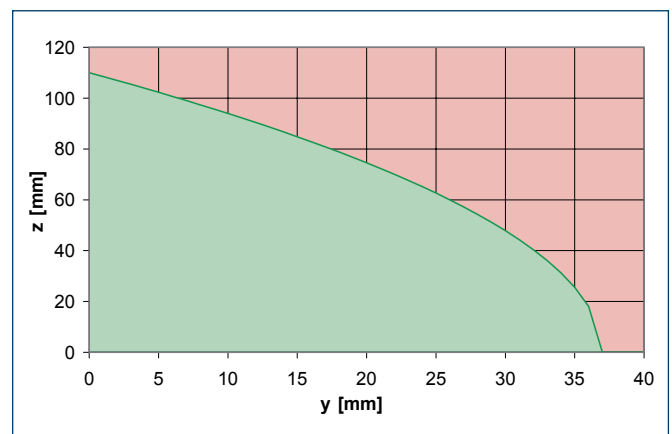
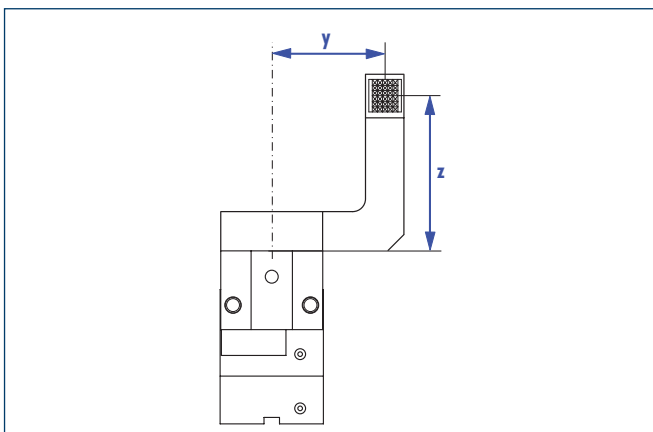

- Permitted range
- Non-permissible range

### Sensor system

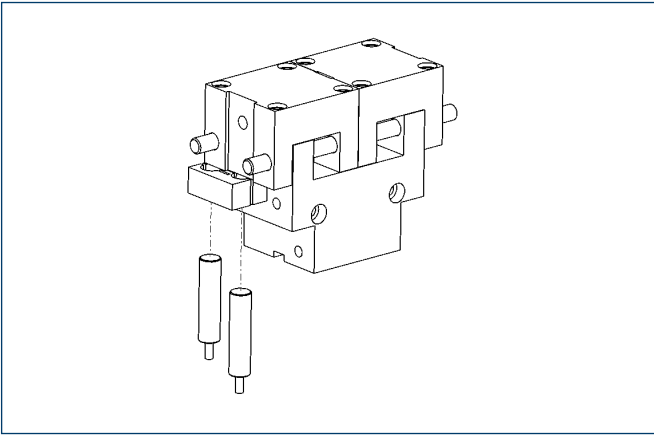

#### End position monitoring:

#### Inductive proximity switches, for direct mounting

Description	ID	Recommended product
IN 80-S-M12	0301578	
IN 80-S-M8	0301478	•
INK 80-S	0301550	

① Two sensors (NO contacts) are required for each gripper, plus extension cables as an option.

#### Extension cables for proximity switches/magnetic switches

Description	ID
KA BG08-L 3P-0300-PNP	0301622
KA BW08-L 3P-0300-PNP	0301594
KA BW08-L 3P-0500-PNP	0301502
KA BW12-L 3P-0300-PNP	0301503
KA BW12-L 3P-0500-PNP	0301507
KV BW08-SG08 3P-0030-PNP	0301495
KV BW08-SG08 3P-0100-PNP	0301496
KV BW08-SG08 3P-0200-PNP	0301497
KV BW12-SG12 3P-0030-PNP	0301595
KV BW12-SG12 3P-0100-PNP	0301596
KV BW12-SG12 3P-0200-PNP	0301597

① Please note the minimum permitted bending radii for the sensor cables, which are generally 35 mm.



You can find more detailed information and individual parts of the above-mentioned accessories in the „Accessories“ catalog section.

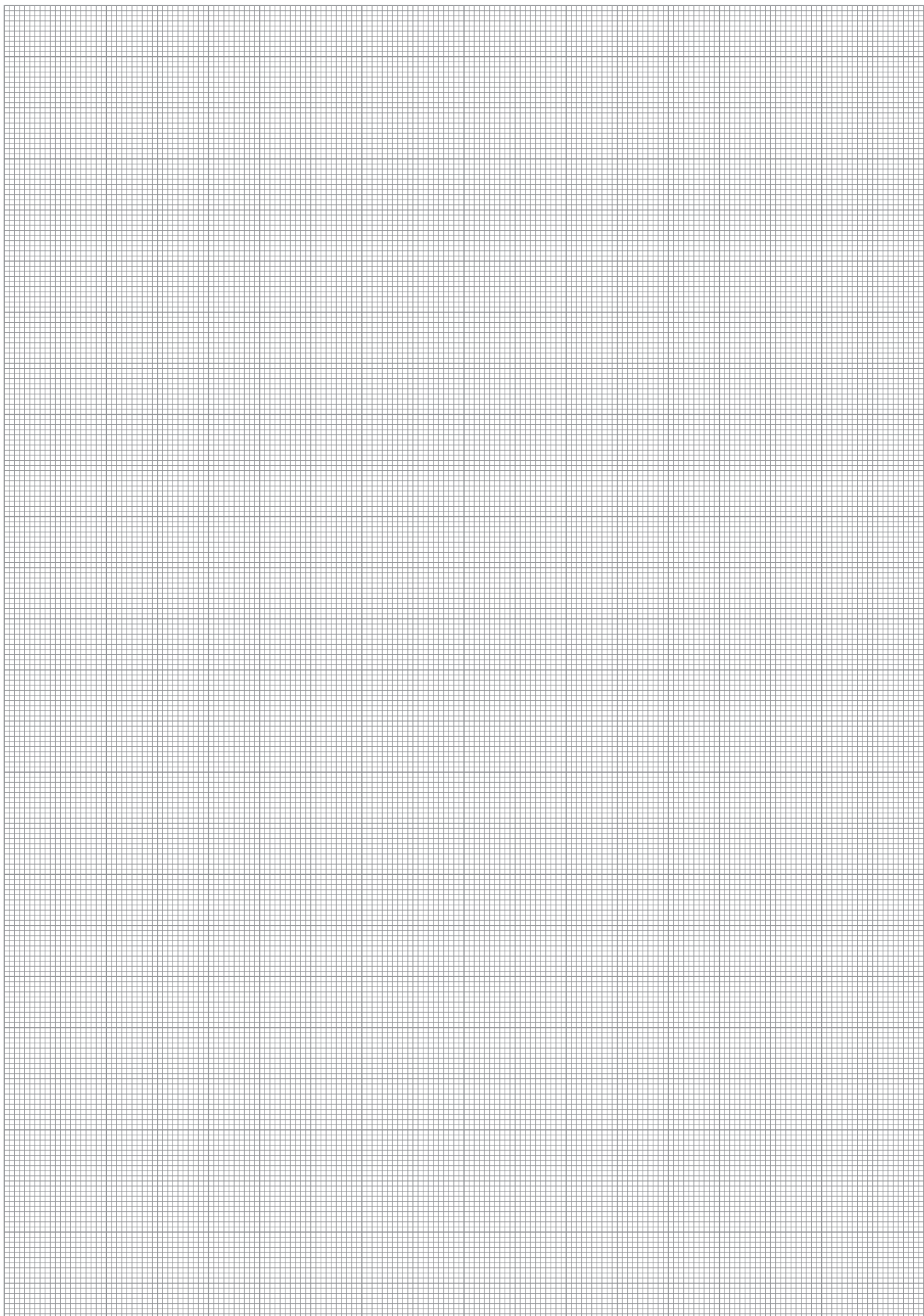



# PGM 140

Pneumatic · 2-Finger Parallel Gripper · **Universal Gripper**

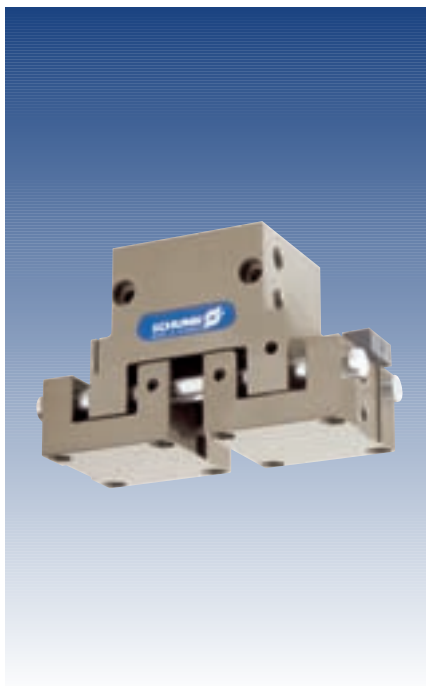

## Gripping force, I.D. gripping

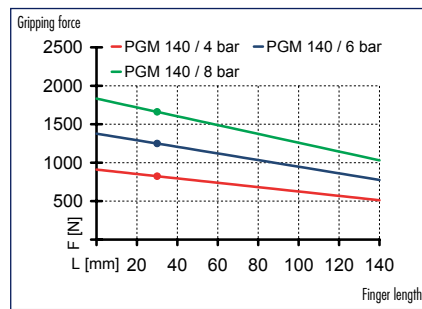

## Gripping force, O.D. gripping

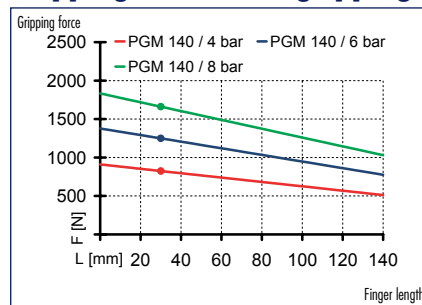

## Finger load

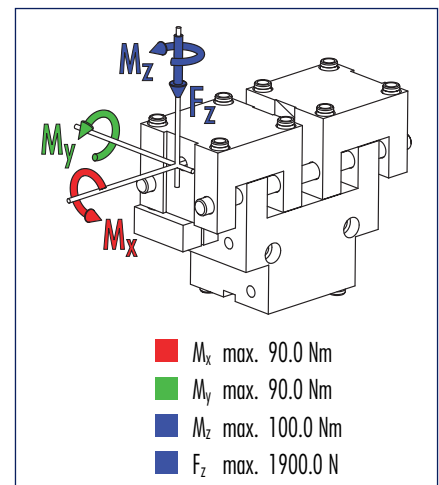

① Moments and forces apply per base jaw and may occur simultaneously.  $M_y$  may arise in addition to the moment generated by the gripping force itself. If the max. permitted finger weight is exceeded, it is imperative to throttle the air pressure so that the jaw movement occurs without any hitting or bouncing. Service life may reduce.

## Technical data

Description	PGM 140	
	ID	0302687
Stroke per finger	[mm]	15.0
Closing force	[N]	1180.0
Opening force	[N]	1250.0
Weight	[kg]	2.55
Recommended workpiece weight	[kg]	5.9
Air consumption per double stroke	[cm <sup>3</sup> ]	46.8
Nominal pressure	[bar]	6.0
Minimum pressure	[bar]	2.0
Maximum pressure	[bar]	8.0
Closing time	[s]	0.12
Opening time	[s]	0.12
Max. permitted finger length	[mm]	140.0
Max. permitted weight per finger	[kg]	1.0
IP class		30
Min. ambient temperature	[°C]	-10.0
Max. ambient temperature	[°C]	90.0
Repeat accuracy	[mm]	0.03

### Main views

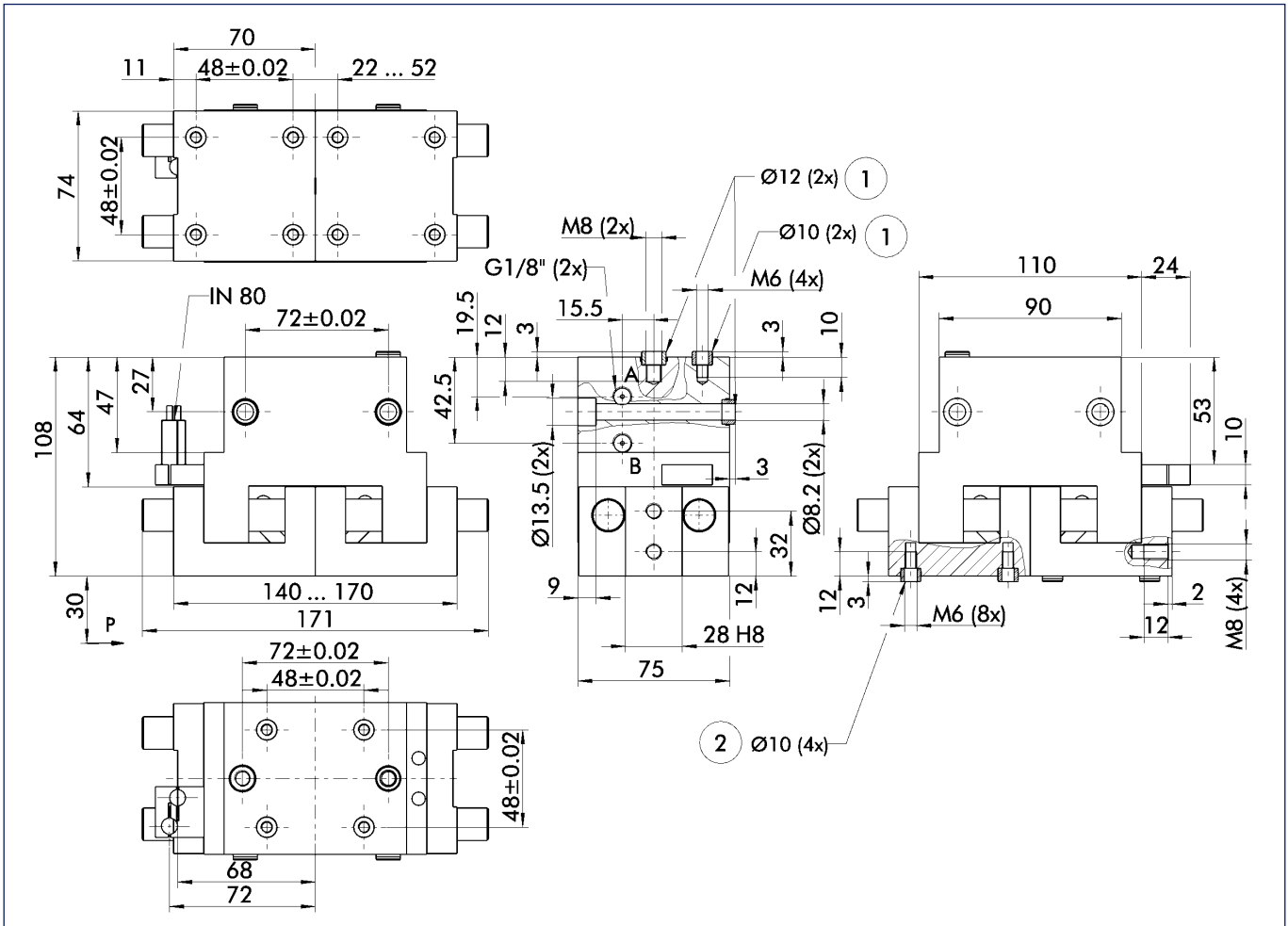

The drawing shows the gripper in the basic version with closed jaws, the dimensions do not include the options described below.

- A,a Main/direct connection, gripper opening
- B,b Main/direct connection, gripper closing
- ① Gripper connection
- ② Finger connection

① The SDV-P pressure maintenance valve can be used as a gripping force safety device (see „Accessories“ catalog section).

### Maximum permitted finger offset

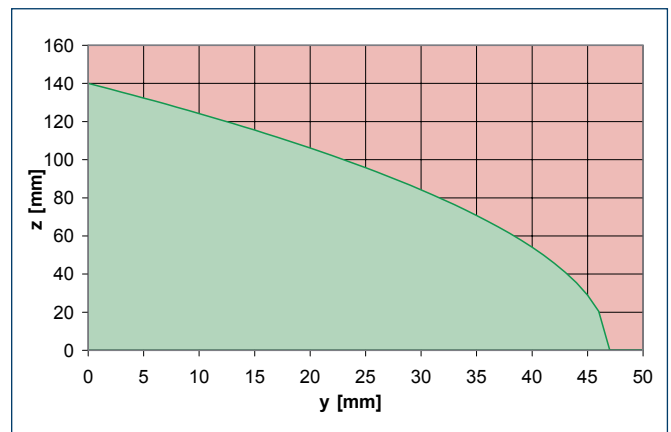
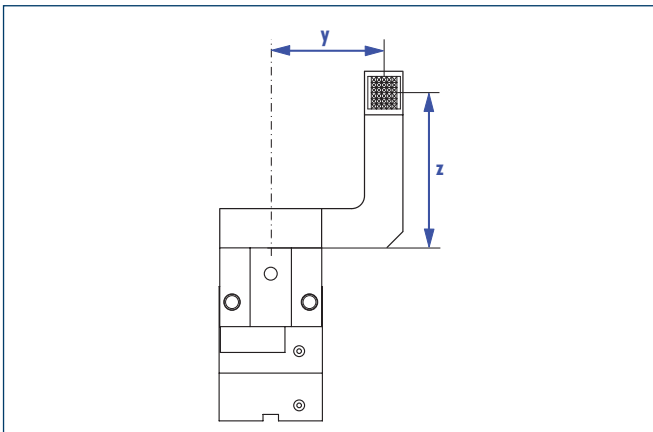

- Permitted range
- Non-permissible range

### Sensor system

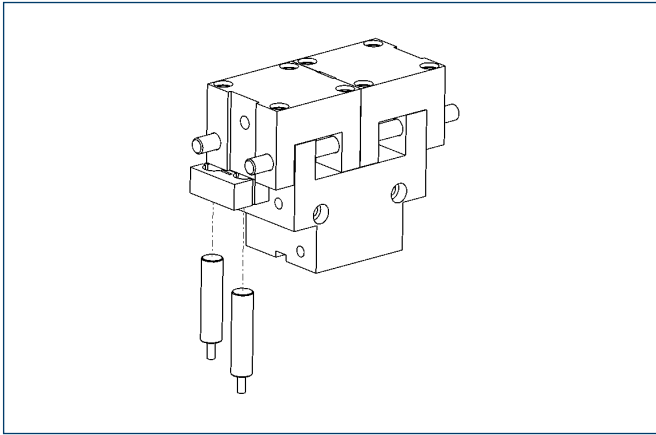

#### End position monitoring:

#### Inductive proximity switches, for direct mounting

Description	ID	Recommended product
IN 80-S-M12	0301578	
IN 80-S-M8	0301478	•
INK 80-S	0301550	

① Two sensors (NO contacts) are required for each gripper, plus extension cables as an option.

#### Extension cables for proximity switches/magnetic switches

Description	ID
KA BG08-L 3P-0300-PNP	0301622
KA BW08-L 3P-0300-PNP	0301594
KA BW08-L 3P-0500-PNP	0301502
KA BW12-L 3P-0300-PNP	0301503
KA BW12-L 3P-0500-PNP	0301507
KV BW08-SG08 3P-0030-PNP	0301495
KV BW08-SG08 3P-0100-PNP	0301496
KV BW08-SG08 3P-0200-PNP	0301497
KV BW12-SG12 3P-0030-PNP	0301595
KV BW12-SG12 3P-0100-PNP	0301596
KV BW12-SG12 3P-0200-PNP	0301597

① Please note the minimum permitted bending radii for the sensor cables, which are generally 35 mm.



You can find more detailed information and individual parts of the above-mentioned accessories in the „Accessories“ catalog section.