

Modular Design

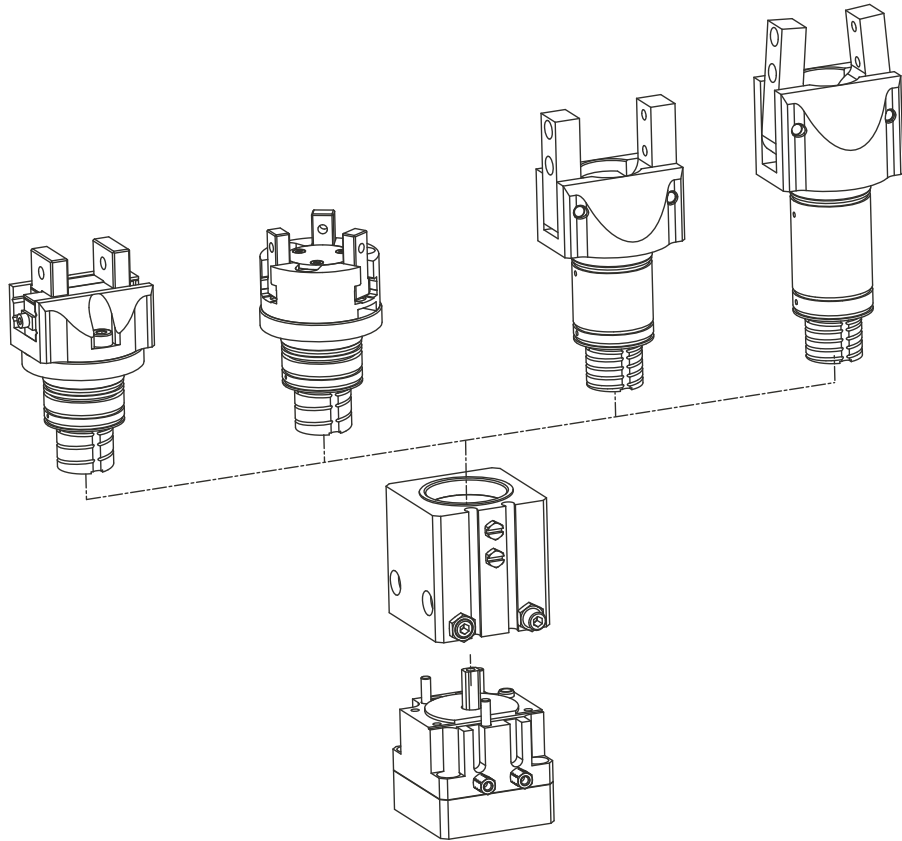

Versions of the series

Type

Gripper type

Size

Gripping force safety device

End position damping

Swivel angle

GSM

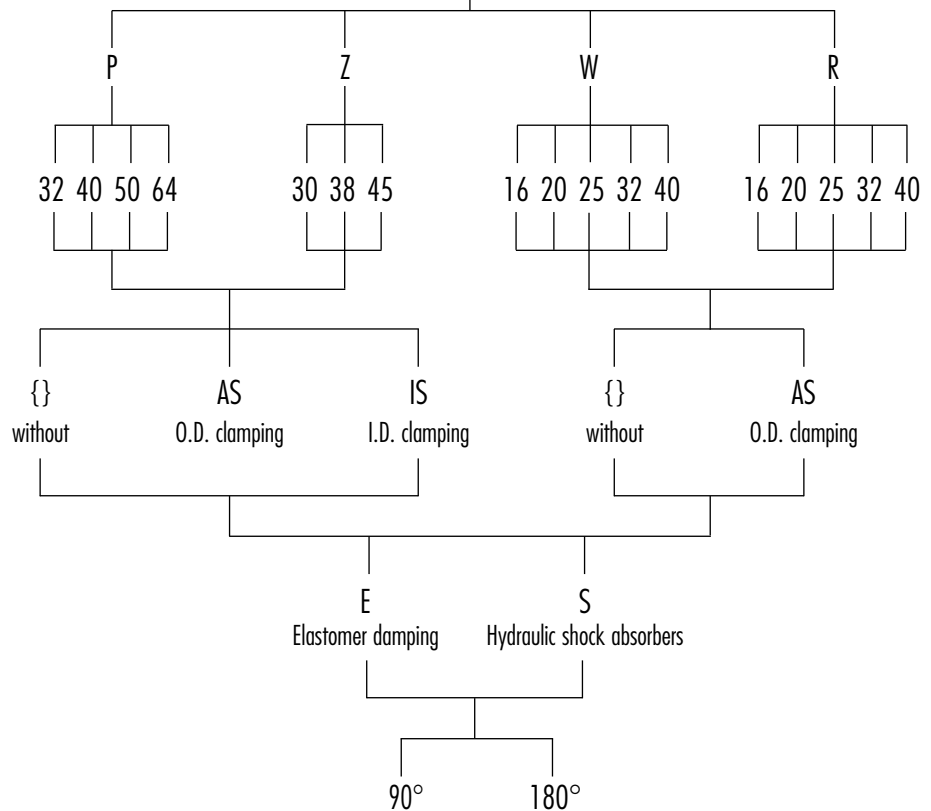

How to order

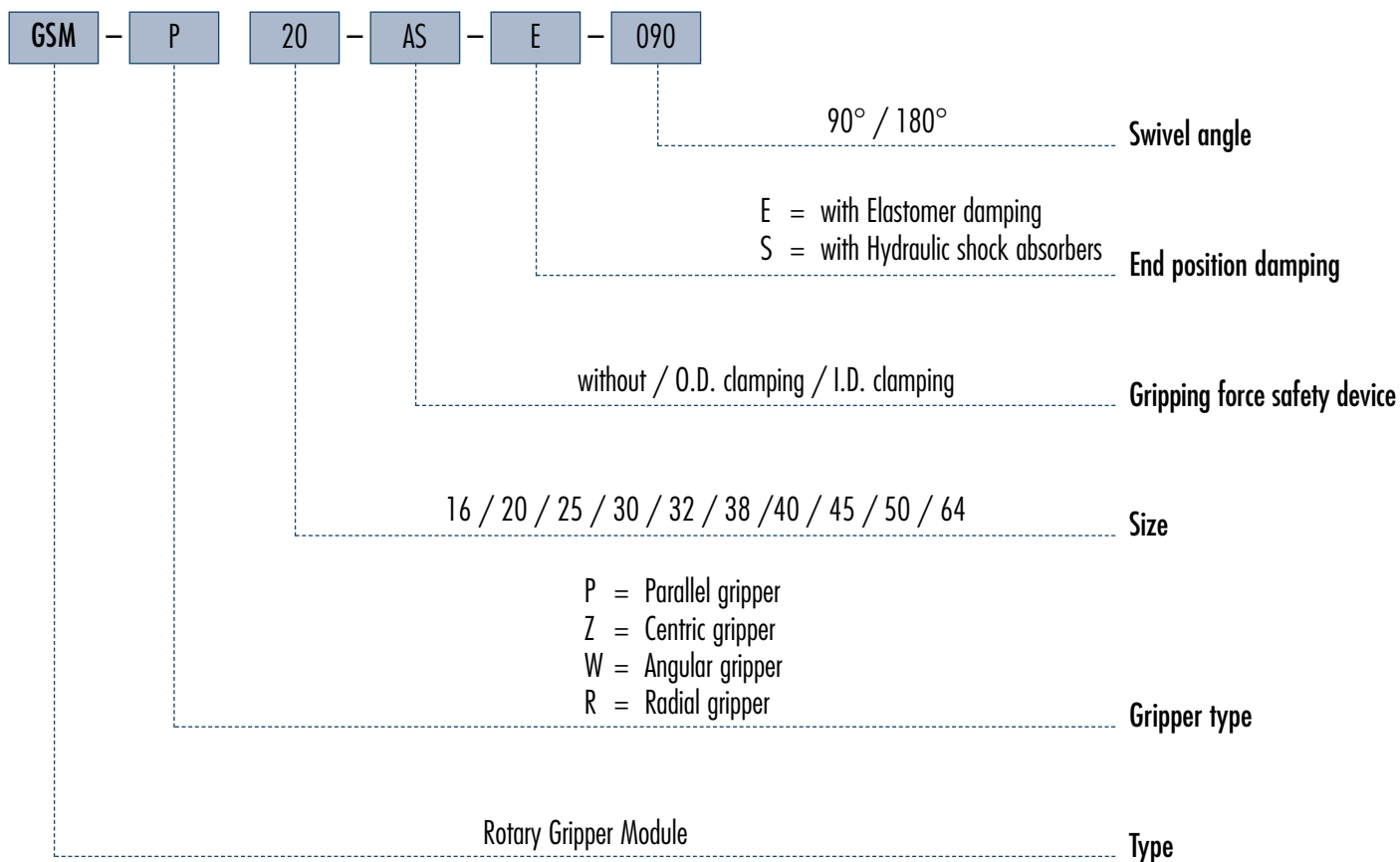

End stop adjustability and switching angle of sensor

- in the case of 90° units

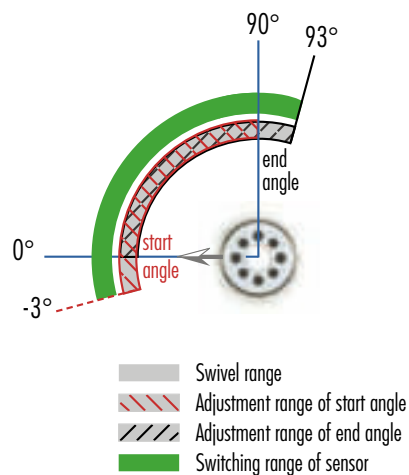

- in the case of 180° units

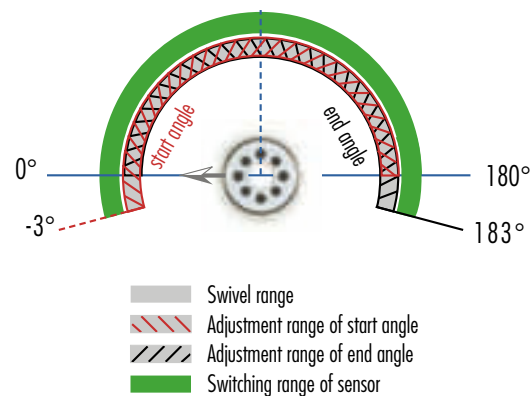



Sizes
16 ... 40



Weight
0.49 kg ... 2.19 kg



Gripping moment
0.9 Nm ... 15 Nm



Angle per jaw
90°

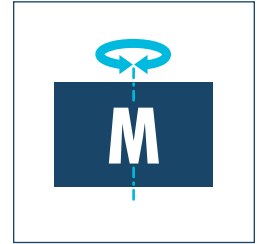

Torque
0.3 Nm ... 2.9 Nm

Application example



Double converter for simultaneous conversion of two workpieces on a separate workpiece carrier.

- 1 GSM-R Gripper Swivel Module
- 2 Linear module LM

Radial Gripper Swivel Module

compact rotary gripper combination, consisting of a powerful pneumatic rotary actuator, an end position and damping mechanism and a radial gripper

Field of application

gripping and rotating combined in a single compact module, for automated assembly in places with a restricted amount of available space

Your advantages and benefits

Space-saving

as the rotary drive, end-position damping unit and gripper are merged in one compact module

Economical

since adapter plates are not needed, there will be costs for project planning and engineering design

Roller guide

for precise gripping through base jaw guidance with minimum play

Process reliability

as moving cables and hoses are replaced by integrated feed-throughs

Comprehensive accessories

through the use of existing gripper components



General note to the series

Principle of function

double-acting, guided kinematics

Housing material

Aluminum alloy, hard-anodized

Base jaw material

Steel

Actuation

pneumatic, with filtered compressed air (10 microns): dry, lubricated or non-lubricated
Pressure medium: Required quality class of compressed air according to DIN ISO 8573-1: 6 4 4

Warranty

24 months (details, general terms and conditions and operation manuals can be downloaded under www.schunk.com)

Scope of delivery

Centering sleeves, O-rings for direct connection, screws for lateral fastening, steel balls for adjustment of the swiveling angle, assembly and operation manual with declaration of incorporation

Gripping force maintenance device

with either mechanical gripping force maintenance or SDV-P pressure maintenance valve

Sectional diagram

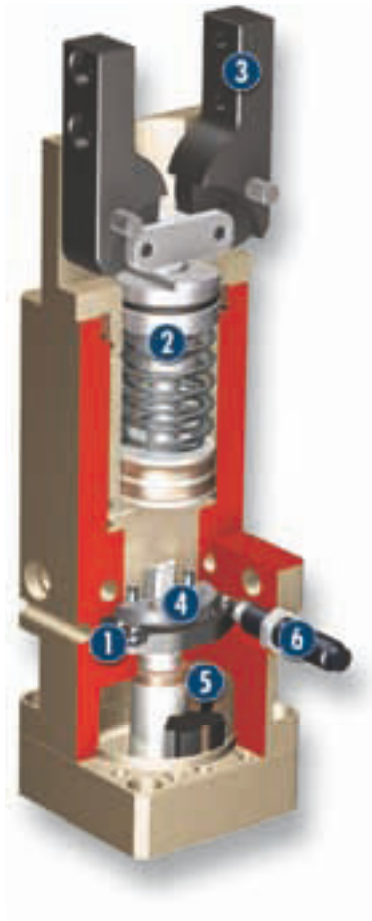

- 1** **Preset of rotating angle**
using steel balls for any desired angle of rotation
- 2** **Gripper drive**
via integrated pneumatic piston

- 3** **Base jaw**
for mounting the top fingers
- 4** **End-position damping assembly**
for end-position adjustment and damping

- 5** **Rotor**
as a compact, powerful drive
- 6** **Hydraulic shock absorber**
to increase the damping performance

Functional description

As its rotor is actuated with pressure, the drive rotates the integrated gripping module. The module itself is driven by its own piston. The piston motion is subsequently transformed into a synchronized gripping motion.

Options and special information

Despite the many options and versions already available as standard, SCHUNK also designs and produces customized versions on request.

Accessories

Accessories from SCHUNK – the suitable supplement for maximum functionality, reliability and performance of all automation modules.

Centering sleeves

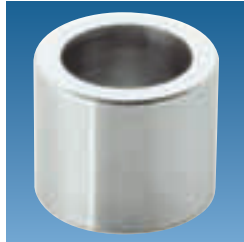

Fittings



Programmable magnetic switch

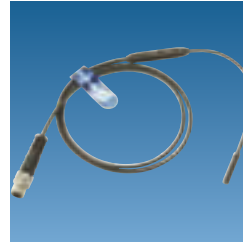

Sensor cables



Plastic inserts

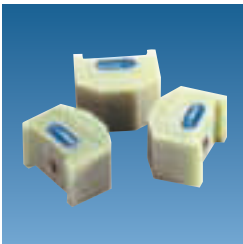

Gripper pads

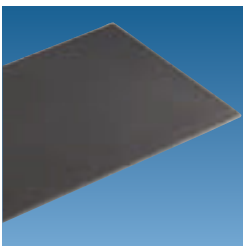

Sensor Distributor



Pressure maintenance valve



① For the exact size of the required accessories, availability of this size and the designation and ID, please refer to the additional views at the end of the size in question. You will find more detailed information on our accessory range in the "Accessories" catalog section.

General note to the series

Gripping moment

Gripping moment is the arithmetic total of gripping moments for each claw jaw.

Finger length

The finger length is measured from the upper edge of the gripper housing in direction to the main axis. If the max. admissible finger length is exceeded, the speed of jaw motions have to be reduced and/or the opening angle has to be diminished, as it is done with heavy fingers. The service life of the gripper can shorten.

Repeat accuracy

is defined as the spread of the limit position after 100 consecutive strokes.

Workpiece weight

The recommended workpiece weight is calculated for a force-type connection with a coefficient of friction of 0.1 and a safety factor of 2 against slippage of the workpiece on acceleration due to gravity g . Considerably heavier workpiece weights are permitted with form-fit gripping.

Closing and opening times, cycle times

Closing and opening times are purely the times that the base jaws or fingers are in motion. Cycle times are purely the times that the rotating part (mostly the pinion) is in motion. Valve switching times, hose filling times or PLC reaction times are not included in the above times and must be taken into consideration when determining cycle times.

Middle attached load

The middle attached load should constitute a typical load. It is defined as the half of the max. possible mass moment of inertia that can be swiveled without restriction, bouncing or hitting, with a centric load and a vertical rotating axis.





Gripping force, O.D. gripping

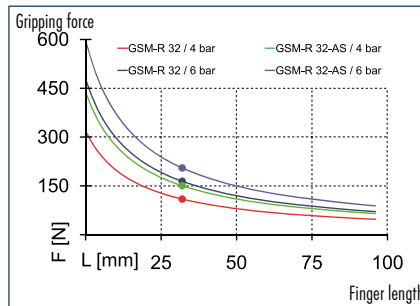

Finger load

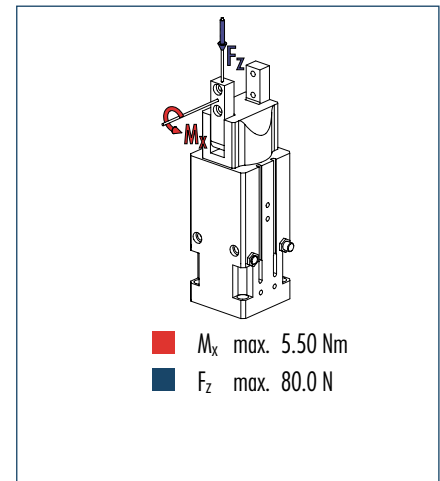

① The indicated moments and forces are static values, apply for each base jaw and should not appear simultaneously. If the maximum admissible finger weight is exceeded, throttling is necessary in order to ensure a smooth jaw motion without jerks or bounces. The life-time may reduce.

Technical data

Description	GSM-R 32-E-090	GSM-R 32-S-090	GSM-R 32-ASE-090	GSM-R 32-AS-S-090
ID	0304678	0304778	0304679	0304779
End position adjustability	[°] 90	90	90	90
Opening angle per jaw	[°] 90	90	90	90
Closed angle per jaw up to	[°] 3.5	3.5	3.5	3.5
Closing moment	[Nm] 8	8	10	10
Spring-actuated closing moment	[Nm] 2	2	2	2
Torque	[Nm] 2.6	2.6	2.6	2.6
Angle of rotation	[°] 90	90	90	90
Recommended workpiece weight	[kg] 0.85	0.85	0.85	0.85
Air consumption for gripping	[cm³] 48.77	48.77	48.77	48.77
Air consumption for swiveling	[cm³] 51	51	51	51
Weight	[kg] 1.83	1.83	1.86	1.86
Nominal operating pressure	[bar] 6	6	6	6
Max. operating pressure	[bar] 6.5	6.5	6.5	6.5
Minimum operating pressure for gripping	[bar] 2	2	4	4
Minimum operating pressure for swiveling	[bar] 3	3	3	3
Closing/opening time	[s] 0.11/0.12	0.11/0.12	0.12/0.17	0.12/0.17
Swiveling time with middle attached load	[s] 0.14	0.14	0.14	0.14
Max. permitted finger length	[mm] 64	64	64	64
Max. permitted weight per finger	[kg] 0.15	0.15	0.15	0.15
IP class	30	30	30	30
Min./max. ambient temperature	[°C] -10/90	5/60	-10/90	5/60
Repeat accuracy for gripping	[mm] 0.02	0.02	0.02	0.02
Repeat accuracy for swiveling	[°] 0.1	0.1	0.1	0.1

OPTIONS and their characteristics

Description	GSM-R 32-E-180	GSM-R 32-S-180	GSM-R 32-ASE-180	GSM-R 32-AS-S-180
ID	0303878	0303978	0303879	0303979
End position adjustability	[°] 180	180	180	180
Air consumption for swiveling	[cm³] 85	85	85	85
Swiveling time with middle attached load	[s] 0.24	0.24	0.24	0.24

Main view

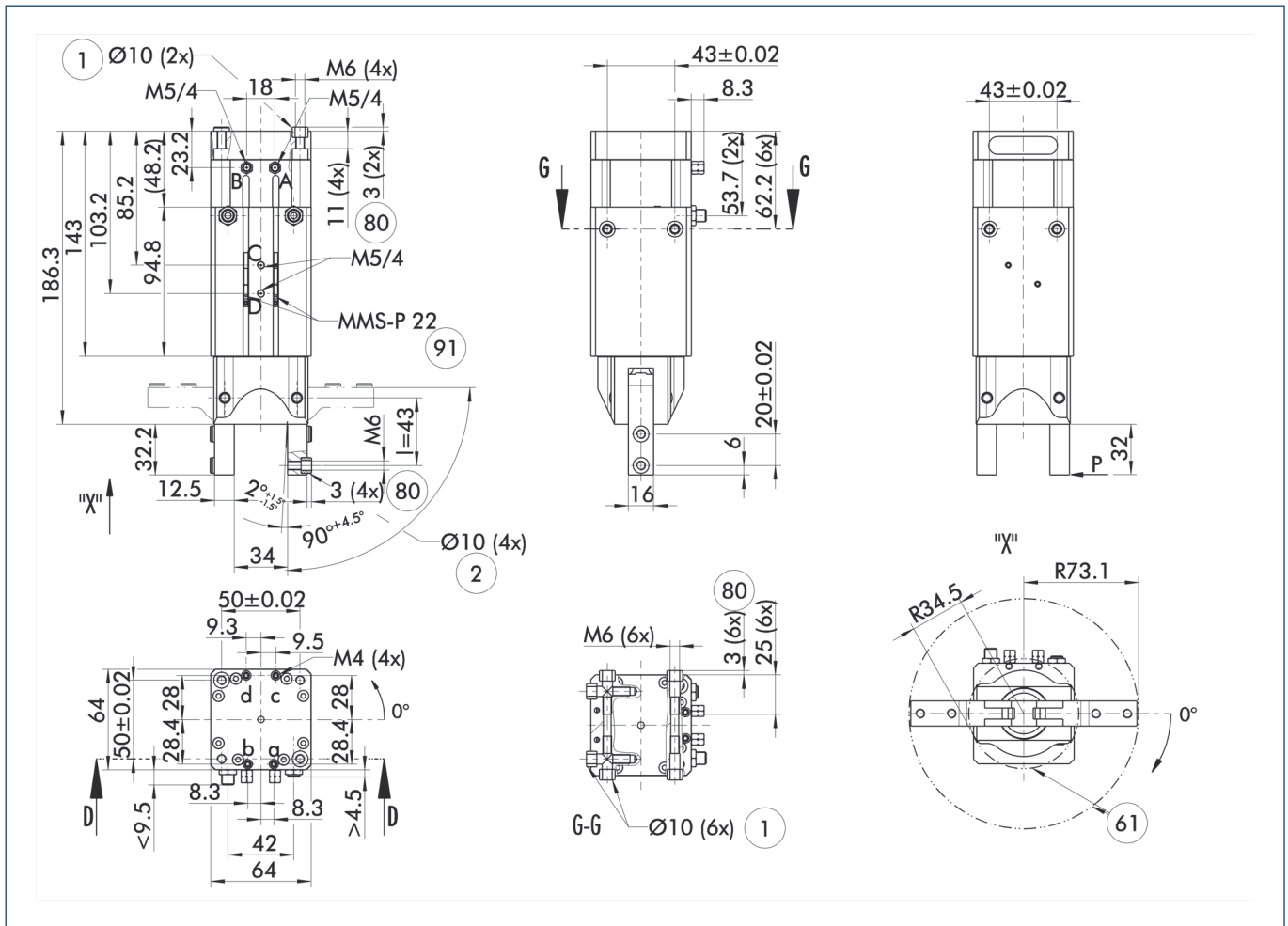

The drawing shows the gripper in the basic version with closed jaws, the dimensions do not include the options described below.

① The SDV-P pressure maintenance valve can also be used for I.D. or O.D. gripping alternatively or in addition to the spring-loaded, mechanical gripping force maintenance device (see "Accessories" catalog section).

- A, a Main/direct connection, rotary actuator clockwise turning
- B, b Main/direct connection, rotary actuator anti-clockwise turning
- C, c Main/direct connection, gripper opening
- D, d Main/direct connection, gripper closing
- ① Connection gripper-rotary actuator
- ② Finger connection
- 61) Interfering contour during swiveling
- 80) Depth of the centering sleeve hole in the matching part
- 91) Monitoring of gripping and swiveling

Hose-free direct connection

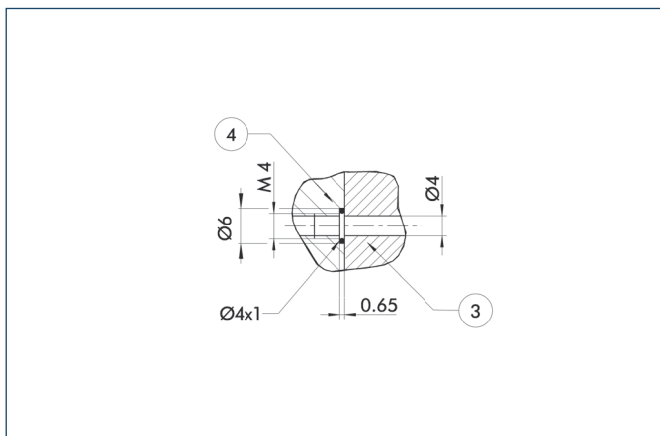

- ③ Adapter
- ④ Gripper swivel module

The direct connection is used for supplying compressed air without hoses. Instead, the pressure medium is fed through bore-holes in the mounting plate.

Version with shock absorbers

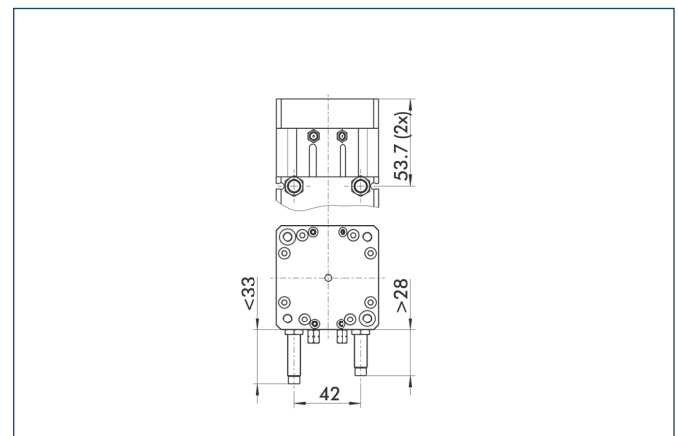

The drawing shows changes in dimensions of the shock absorber versions, compared to the elastomer versions shown on the main view.

Stacked arrangement

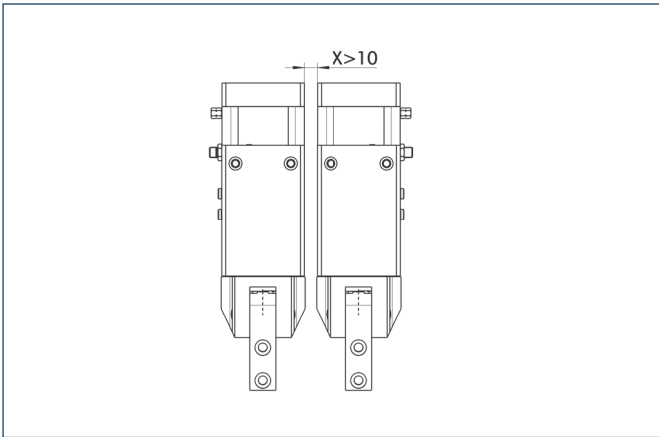

CAUTION: Monitoring is carried out by magnetic switches, and in case of side-by-side assembly of several units, a minimum distance of X mm between the units must be maintained.

Programmable magnetic switch

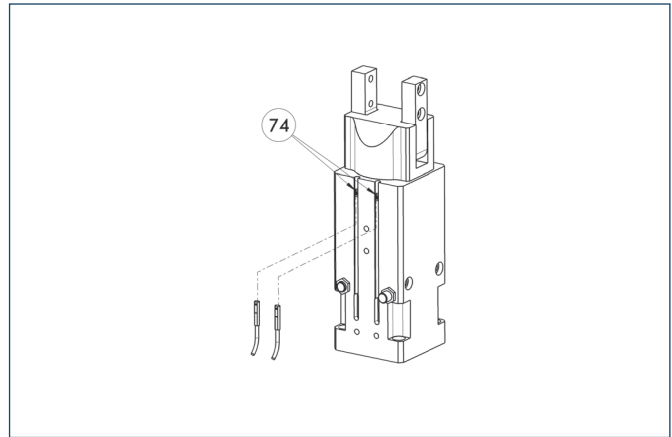

74 Stop for MMS-P

Position monitoring with two programmable positions per sensor. The end position monitoring is mounted in the C-slot.

Description	ID	Recommended product
Programmable magnetic switch		
MMS-P 22-S-M8-PNP	0301370	•
MMSK-P 22-S-PNP	0301371	
Connection cables		
KA BG08-L 4P-0500	0307767	
KA BG08-L 4P-1000	0307768	
KA BW08-L 4P-0500	0307765	
KA BW08-L 4P-1000	0307766	
Sensor Distributor		
V2-M8-4P-2XM8-3P	0301380	

- ① Please note the minimum permitted bending radii for the sensor cables, which are generally 35 mm.
- ① Per each GSM two sensors MMS-P are required. If standard extension cables (M8-3P) are used, the sensor distributor can be applied.

