

Duplex-tank top return line filter

Pi 5100

Nominal size 40 up to 1000
according DIN 24550

1. Features

High performance filters for modern hydraulic systems

- Provided for tank top installation
- Modular system
- Compact design
- Minimal pressure drop through optimal flow design
- Visual/electrical/electronic maintenance indicator
- Threaded and flanged connections
- Quality filters, easy to service
- Equipped with highly efficient glass fibre PS filter elements
- Beta rated elements according to ISO 16889 multipass test
- Elements with high differential pressure stability and dirt holding capacity
- Worldwide distribution



2. Flow rate/pressure drop curve complete filter

see data sheet Pi 5000

3. Separation grade characteristics

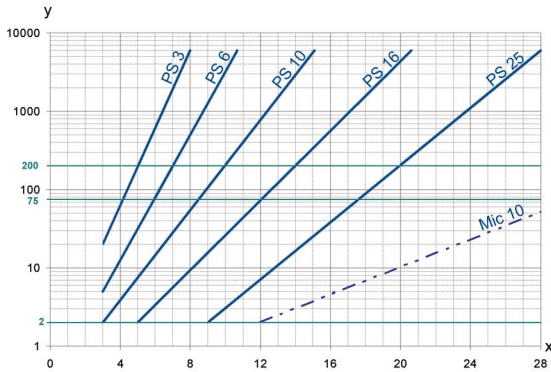

y = beta-value

x = particle size [μm]

determined by multipass tests (ISO 16889)
calibration according to ISO 1171 (NIST)

4. Filter performance data

tested according to ISO 16889 (multipass test)

PS elements with

max. Δp 10 bar

PS 3 $\beta_{5(C)} \geq 200$

PS 6 $\beta_{7(C)} \geq 200$

PS 10 $\beta_{10(C)} \geq 200$

PS 16 $\beta_{15(C)} \geq 200$

PS 25 $\beta_{20(C)} \geq 200$

values guaranteed up to
5 bar differential pressure

5. Quality assurance

MAHLE filters and filter elements are produced according to the following international standards:

Norm	Designation
DIN ISO 2941	Hydraulic fluid power filter elements; verification of collapse/burst resistance
DIN ISO 2942	Hydraulic fluid power filter elements; verification of fabrication integrity
DIN ISO 2943	Hydraulic fluid power filter elements; verification material compatibility with fluids
DIN ISO 3723	Fluidtechnik-Hydraulik Filterelemente; method for end load test
DIN ISO 3724	Hydraulic fluid power filter elements; verification of flow fatigue characteristics
ISO 3968	Hydraulic fluid power filters; evaluation of pressure drop versus flow characteristics
ISO 10771.1	Fatigue pressure testing of metal containing envelopes in hydraulic fluid applications
ISO 16889	Hydraulic fluid power filters; multipass method for evaluation filtration performance of a filter element

6. Symbols

see data sheet Pi 5000

7. Order numbers

7.1 Housing design

Nominal size NG [l/min]	Order number	Type	①	②	③	with electrical indicator (2 setting points, 3 LED)
			with bypass 3.5 bar and indicator cavity	with bypass 3.5 bar and visual indicator 2.2 bar	with bypass 3.5 bar and electrical indicator 2.2 bar	
40	78337438	Pi 51004-047				
	78275729	Pi 51004-057				
	78275737	Pi 51004-058				
	78278202	Pi 51004-058/PiS 3103				
63	78337446	Pi 51006-047				
	78275513	Pi 51006-057				
	78275307	Pi 51006-058				
	78337453	Pi 51006-058/PiS 3103				
100	77994320	Pi 51010-047				
	78274110	Pi 51010-057				
	77993306	Pi 51010-058				
	78337461	Pi 51010-058/PiS 3103				
160	78276453	Pi 51016-047				
	78337479	Pi 51016-057				
	78276644	Pi 51016-058				
	78267775	Pi 51016-058/PiS 3103				
250	78276479	Pi 51025-047				
	78336323	Pi 51025-057				
	78316044	Pi 51025-058				
	78276420	Pi 51025-058/PiS 3103				
400	78276487	Pi 51040-047				
	78337495	Pi 51040-057				
	78337503	Pi 51040-058				
	78337511	Pi 51040-058/PiS 3103				
630	78276495	Pi 51063-047/6				
	78336844	Pi 51063-057/6				
	78336547	Pi 51063-058/6				
	78337529	Pi 51063-058/6/PiS 3103				
1000	78337537	Pi 51100-047				
	78337545	Pi 51100-057				
	78337420	Pi 51100-058				
	78337552	Pi 51100-0/PiS 3103				

When filter with non bypass configuration is selected, the collapse pressure of the element must not be exceeded.

7.2 Filter elements

see data sheet Pi 5000

8. Technical specifications

see data sheet Pi 5000

9. Dimensions

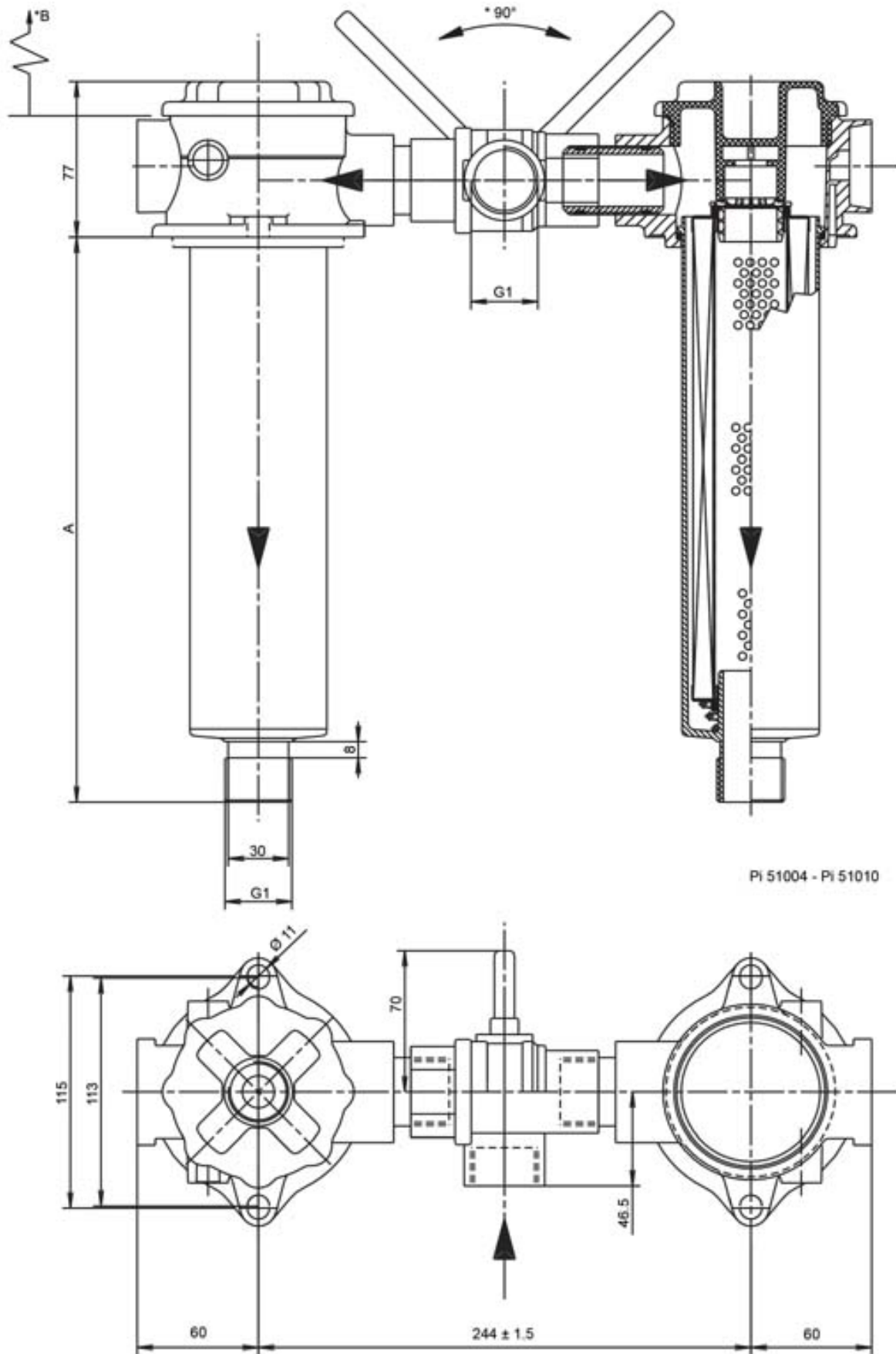

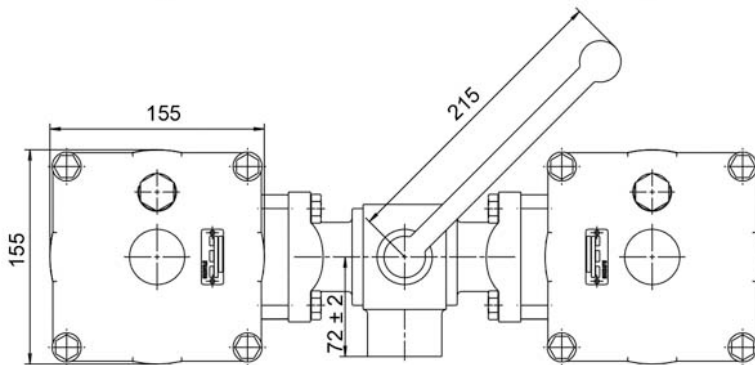
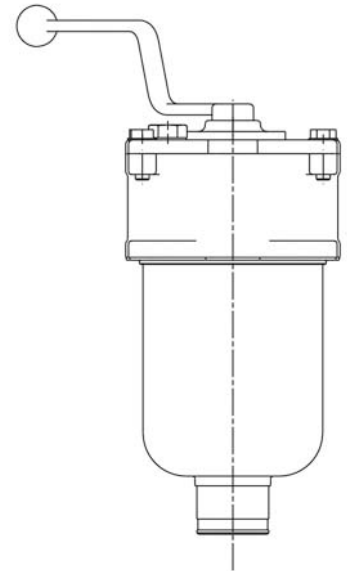
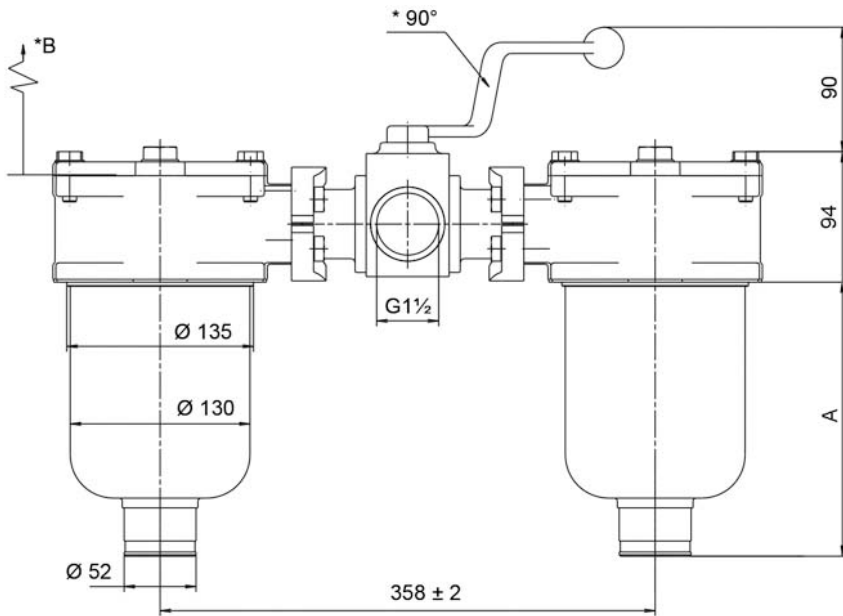

Pi 51016 - Pi 51025

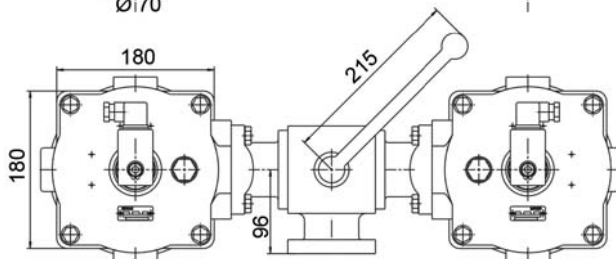
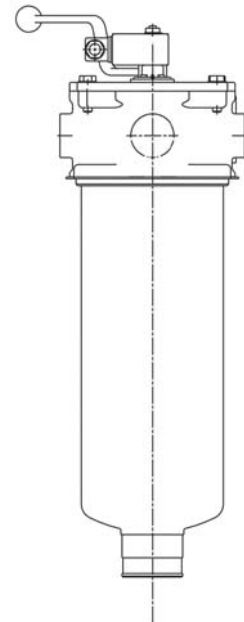
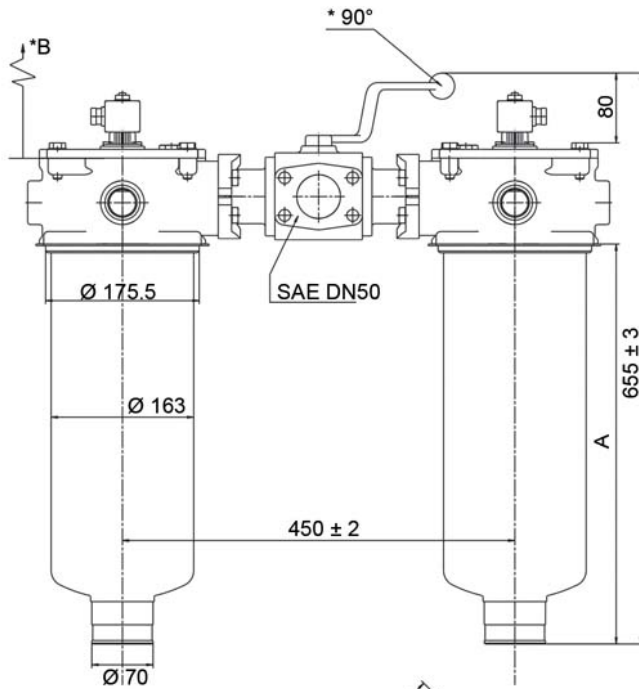

Pi 51040 - Pi 51063

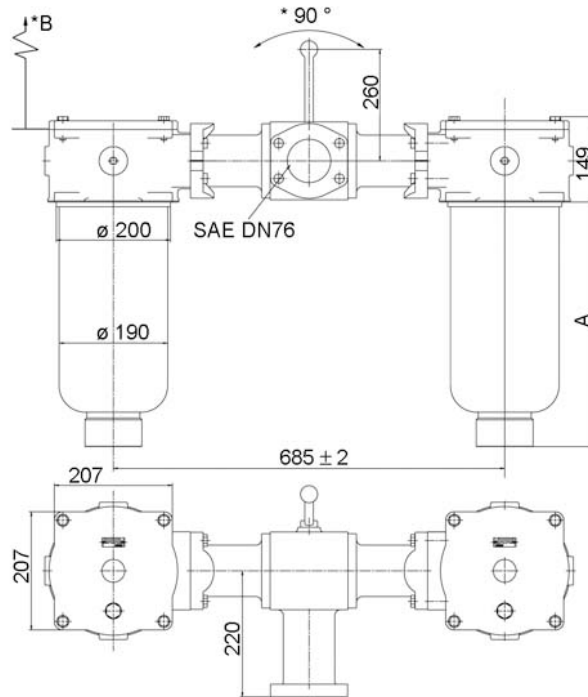

Pi 51100

*B= Minimum clearance for filter element removal

* 90°= Pivoting range

Type	A	B
Pi 51004	130	150
Pi 51006	190	210
Pi 51010	280	300
Pi 51016	207	220
Pi 51025	297	310
Pi 51040	309	480
Pi 51063	459	480
Pi 51100	427	450

10. Installation, operating and maintenance instructions

see data sheet Pi 5000

11. Spare parts list

see data sheet Pi 5000

MAHLE Industriefiltration GmbH
 Schleifbachweg 45
 74613 Öhringen
 Phone +49 79 41 67-0
 Fax +49 79 41 67-2 34 29
 industrialfiltration@mahle.com
 www.mahle-industriefiltration.com
 70364395.03/2012