

MAHLE

Industry

Electronic maintenance indicators

PiS 3300-2.9 2SP LED

1. Features

Filter elements are economically used only if their dirt holding capacity is fully exploited. A reliable indication of the optimal time to replace the element both on the filter itself and in the plant control or monitoring system is therefore vital. In a return line filter, the flow resistance increases as a function of operating time owing to the dirt that is retained in the filter element and the differential pressure rises accordingly. The service life can now be additionally extended thanks to an intelligent monitoring device for differential pressure.

The newly developed PiS 3300-2.9 2SP LED maintenance indicator is a self-checking, microprocessor-controlled pressure switch for MAHLE return line filters with two alarm outputs, high-intensity LEDs for all-round visibility and pulse and cold start suppression.



2. Function

An electronic pressure sensor measures the pressure continuously upstream of the return line filter element. The oil temperature is simultaneously measured by a temperature sensor. The device swaps to operation mode as soon as the filter reaches its normal service temperature ($> 30\text{ °C}$); this is indicated by the green LEDs lighting up permanently. The temperature and pressure sensors are installed in the same measuring cell, in direct contact with the hydraulic oil inside the filter. The pressure and temperature are thus measured without any intervening mechanical parts. If the oil temperature falls below 30 °C , the green LEDs flash and the alarm outputs are locked to prevent false alarms due to high viscosity during cold starts.

If the pressure in the filter reaches 2.2 bar at operating temperature because the filter element is exhausted, one alarm output (NO contact) is activated and the yellow LEDs also light up. This corresponds to 75 % of the maximum value.

At the maximum pressure value (2.9 bar), a second alarm output (NC contact) is activated and the red LEDs light up as well. It is now time to replace the filter element!

3. Technical specifications

Material:	Aluminium/plastic
Seals:	NBR*
Nominal pressure:	10 bar (144 psi)
Burst pressure:	approx. 25 bar (360 psi)
Temperature range:	-20 °C to $+85\text{ °C}$
Max. voltage:	24 V DC $\pm 10\%$
Max. current:	$< 100\text{ mA}$
Max. switching current at outputs:	1 A at 24 V DC
Cable sleeve:	M12x1
Type of protection:	IP 65
Signal suppression:	$< 30\text{ °C}$
Min. time to activate outputs:	4 s

* other seals on request

5. Order numbers

Type	Order number
PiS 3300-2.9 2SP LED	70360437

MAHLE Industriefiltration GmbH
 Schleifbachweg 45
 74613 Öhringen
 Phone +49 7941 67-0
 Fax +49 7941 67-23429
 industrialfiltration@mahle.com
 www.mahle-industrialfiltration.com
 70382747.05/2012

The switching values are much higher than with mechanical pressure switches because the sensor measures directly and extremely precisely with almost no hysteresis. This makes for more efficient use of the element capacity, so that the service life of the filter elements is prolonged and the overall costs of ownership reduced.

Short-term pressure peaks (up to 4 s) in the return line, for example owing to the high return flow rate when the tank is discharged, are suppressed to prevent false alarms.

The switching states of the electrical outputs and the LEDs remain stored when the plant is shut down until the reset button is pressed or the indicator power supply interrupted (e.g. by unplugging the cable).

This pressure indicator can be used with all MAHLE return line filters in the Pi 5000 series from size 40 to 1000.

4. Dimensions

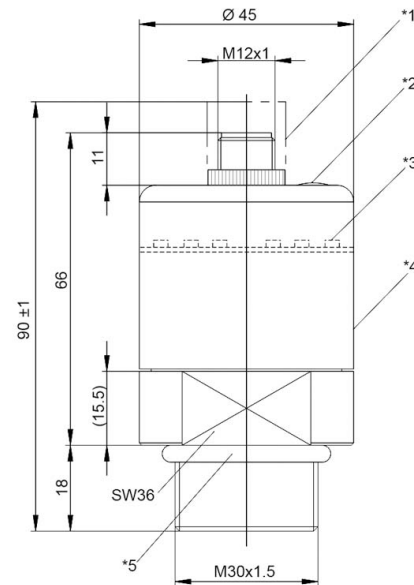

*1 = Protection cap

*2 = Reset button

*3 = LED corona

*4 = MAHLE type plate

*5 = O-Ring 26.5x3.2 NBR

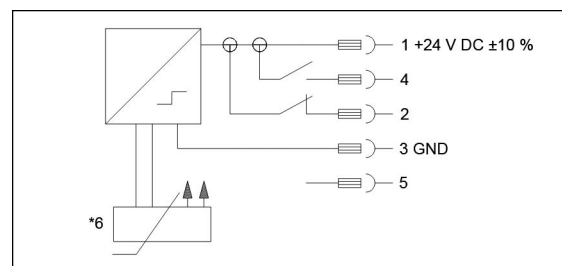

4 = Output 1

2 = Output 2

*6 = Temperature sensor