

Duplex Filter Pi 2100

Nominal pressure 32/63 bar (460/900 psi), nominal size up to 400
according to DIN 24550

1. Features

High performance filters for modern hydraulic systems

- Modular system
- Compact design
- Minimal pressure drop through optimal flow design
- Visual/electrical/electronic maintenance indicator
- Threaded connections
- Change over valve on upstream side
- Ergonomic switch-over handle with safety lock and pressure compensation
- User-optimized one-hand-operation
- Equipped with highly efficient glass fibre PS filter elements
- Beta rated elements according to ISO 16889 multipass test
- Elements with high differential pressure stability and dirt holding capacity
- Other connections on request
- Worldwide distribution



2. Flow rate/pressure drop curve complete filter

■ 190 mm²/s
■ 33 mm²/s

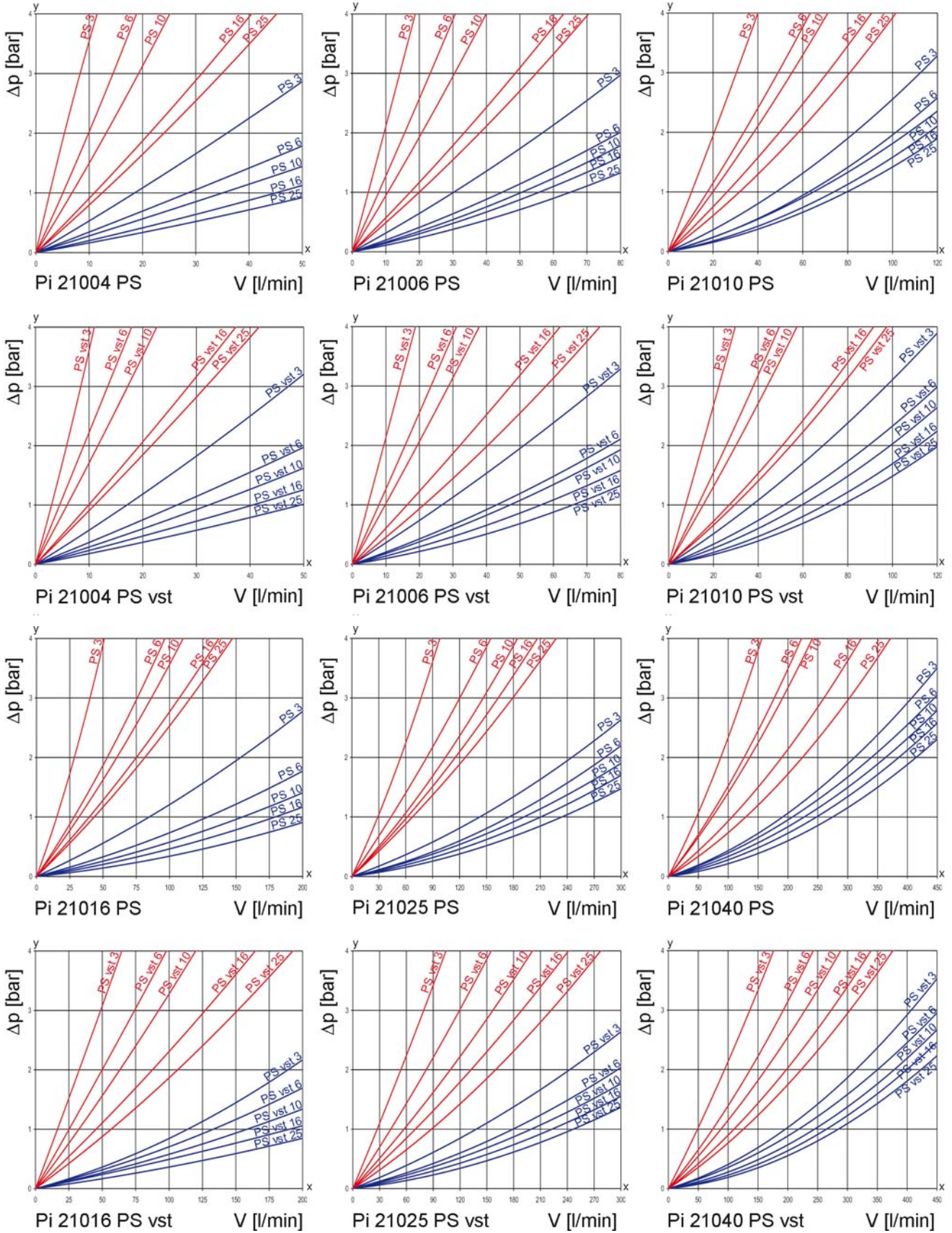

y = differential pressure Δp [bar]

x = flow rate V [l/min]

Calculation of individual filter under www.industrialfiltration-catalogue.mahle.com

3. Separation grade characteristics

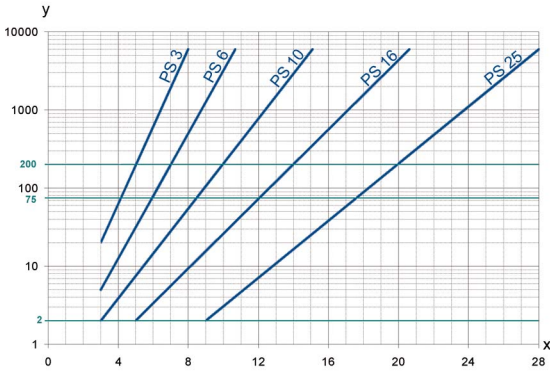

y = beta-value
x = particle size [μm]

determined by multipass tests (ISO 16889)
calibration according to ISO 11171 (NIST)

4. Filter performance data

tested according to ISO 16889 (multipass test)

PS elements with
max. Δp 20 bar

PS	3	$\beta_{5(C)} \geq 200$
PS	6	$\beta_{7(C)} \geq 200$
PS	10	$\beta_{10(C)} \geq 200$
PS	16	$\beta_{15(C)} \geq 200$
PS	25	$\beta_{20(C)} \geq 200$

values guaranteed up to
10 bar differential pressure

PS vst elements with
max. Δp 210 bar

PS vst	3	$\beta_{5(C)} \geq 200$
PS vst	6	$\beta_{7(C)} \geq 200$
PS vst	10	$\beta_{10(C)} \geq 200$
PS vst	16	$\beta_{15(C)} \geq 200$
PS vst	25	$\beta_{20(C)} \geq 200$

values guaranteed up to
20 bar differential pressure

5. Quality assurance

MAHLE filters and filter elements are produced according to the following international standards:

Norm	Designation
DIN ISO 2941	Hydraulic fluid power filter elements; verification of collapse/burst resistance
DIN ISO 2942	Hydraulic fluid power filter elements; verification of fabrication integrity
DIN ISO 2943	Hydraulic fluid power filter elements; verification of material compatibility with fluids
DIN ISO 3723	Hydraulic fluid power filter elements; method for end load test
DIN ISO 3724	Hydraulic fluid power filter elements; verification of flow fatigue characteristics
ISO 3968	Hydraulic fluid power filters; evaluation of pressure drop versus flow characteristics
ISO 10771.1	Fatigue pressure testing of metal containing envelopes in hydraulic fluid applications
ISO 16889	Hydraulic fluid power filters-multipass method for evaluation filtration performance of a filter element

6. Symbols

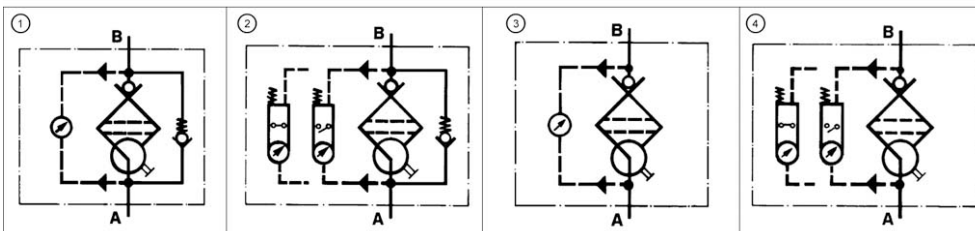

7. Order numbers

Example for ordering filter:

1. Housing design	2. 2x Filter elements
V = 100 l/min and electrical maintenance indicator Type: Pi 21010-069 Order number: 78204158	PS vst 3 NBR Type: Pi 71010 DN PS vst 3 Order number: 78227480

7.1 Housing design

Nominal size NG [l/min]	Order number	Type	① with bypass valve and visual indicator	② with bypass valve and electrical indicator	③ with visual indicator	④ with electrical indicator
40	79328261	Pi 21004-057				
	78304263	Pi 21004-058				
	79328279	Pi 21004-068				
	79328287	Pi 21004-069				
63	79715905	Pi 21006-057				
	78304271	Pi 21006-058				
	79715913	Pi 21006-068				
	79715921	Pi 21006-069				
100	78204125	Pi 21010-057				
	78204133	Pi 21010-058				
	78204141	Pi 21010-068				
	78204158	Pi 21010-069				
160	79715939	Pi 21016-057				
	79715947	Pi 21016-058				
	79715954	Pi 21016-068				
	79715962	Pi 21016-069				
250	79328295	Pi 21025-057				
	79328303	Pi 21025-058				
	79328311	Pi 21025-068				
	79328329	Pi 21025-069				
400	79715970	Pi 21040-057				
	79715988	Pi 21040-058				
	79715996	Pi 21040-068				
	79716002	Pi 21040-069				

When filter with non bypass configuration is selected, the collapse pressure of the element must not be exceeded.

7.2 Filter elements*

Nominal size NG [l/min]	Order number	Type	Filter material	max. Δp [bar]	Filter surface [cm ²]
40	78260929	Pi 21004 DN PS 3	PS 3	20	475
	77960859	Pi 22004 DN PS 6	PS 6		475
	77925571	Pi 23004 DN PS 10	PS 10		475
	78260937	Pi 24004 DN PS 16	PS 16		475
	78260945	Pi 25004 DN PS 25	PS 25		475
	78216079	Pi 71004 DN PS vst 3	PS vst 3	210	445
	77960156	Pi 72004 DN PS vst 6	PS vst 6		445
	77925654	Pi 73004 DN PS vst 10	PS vst 10		445
	78216087	Pi 74004 DN PS vst 16	PS vst 16		445
	78216095	Pi 75004 DN PS vst 25	PS vst 25		445
63	78260960	Pi 21006 DN PS 3	PS 3	20	835
	77960867	Pi 22006 DN PS 6	PS 6		835
	77925589	Pi 23006 DN PS 10	PS 10		835
	78260978	Pi 24006 DN PS 16	PS 16		835
	78260986	Pi 25006 DN PS 25	PS 25		835
	78216137	Pi 71006 DN PS vst 3	PS vst 3	210	780
	77960149	Pi 72006 DN PS vst 6	PS vst 6		780
	77925662	Pi 73006 DN PS vst 10	PS vst 10		780
	78216145	Pi 74006 DN PS vst 16	PS vst 16		780
	78216152	Pi 75006 DN PS vst 25	PS vst 25		780
100	78227472	Pi 21010 DN PS 3	PS 3	20	1375
	77960875	Pi 22010 DN PS 6	PS 6		1375
	77925597	Pi 23010 DN PS 10	PS 10		1375
	78261000	Pi 24010 DN PS 16	PS 16		1375
	78261018	Pi 25010 DN PS 25	PS 25		1375
	78227480	Pi 71010 DN PS vst 3	PS vst 3	210	1275
	77960131	Pi 72010 DN PS vst 6	PS vst 6		1275
	77925670	Pi 73010 DN PS vst 10	PS vst 10		1275
	78261281	Pi 74010 DN PS vst 16	PS vst 16		1275
	78216160	Pi 75010 DN PS vst 25	PS vst 25		1275
160	78261034	Pi 21016 DN PS 3	PS 3	20	2530
	77960826	Pi 22016 DN PS 6	PS 6		2530
	77925605	Pi 23016 DN PS 10	PS 10		2530
	78261042	Pi 24016 DN PS 16	PS 16		2530
	78261059	Pi 25016 DN PS 25	PS 25		2530
	77940638	Pi 71016 DN PS vst 3	PS vst 3	210	1885
	77960123	Pi 72016 DN PS vst 6	PS vst 6		1885
	77925688	Pi 73016 DN PS vst 10	PS vst 10		1885
	78269797	Pi 74016 DN PS vst 16	PS vst 16		1885
	78216178	Pi 75016 DN PS vst 25	PS vst 25		1885

*a wider range of elements is available on request

7.2 Filter elements*

Nominal size NG [l/min]	Order number	Type	Filter material	max. Δp [bar]	Filter surface [cm ²]
250	78227514	Pi 21025 DN PS 3	PS 3	20	4020
	77960834	Pi 22025 DN PS 6	PS 6		4020
	77925613	Pi 23025 DN PS 10	PS 10		4020
	78261075	Pi 24025 DN PS 16	PS 16		4020
	78261083	Pi 25025 DN PS 25	PS 25		4020
	77940646	Pi 71025 DN PS vst 3	PS vst 3	210	3090
	77960115	Pi 72025 DN PS vst 6	PS vst 6		3090
	77925696	Pi 73025 DN PS vst 10	PS vst 10		3090
	78269813	Pi 74025 DN PS vst 16	PS vst 16		3090
	78216186	Pi 75025 DN PS vst 25	PS vst 25		3090
400	78227522	Pi 21 040 DN PS 3	PS 3	20	6770
	77960842	Pi 22 040 DN PS 6	PS 6		6770
	77925621	Pi 23 040 DN PS 10	PS 10		6770
	78261109	Pi 24 040 DN PS 16	PS 16		6770
	78261117	Pi 25 040 DN PS 25	PS 25		6770
	77940653	Pi 71 040 DN PS vst 3	PS vst 3	210	5240
	77960107	Pi 72 040 DN PS vst 6	PS vst 6		5240
	77930829	Pi 73 040 DN PS vst 10	PS vst 10		5240
	78269821	Pi 74 040 DN PS vst 16	PS vst 16		5240
	78260903	Pi 75 040 DN PS vst 25	PS vst 25		5240

*a wider range of elements is available on request

8. Technical specifications

Design:	line mounting filter
Nominal pressure:	
Pi 21004-21010	10 ⁷ load changes 63 bar (900 psi)
Pi 21016-21040	10 ⁷ load changes 25 bar (360 psi) 2x 10 ⁶ load changes 32 bar (460 psi)
Test pressure:	
Pi 21004-21010	95 bar (1370 psi)
Pi 21016-21040	48 bar (690 psi)
Temperature range:	-10 °C to +120 °C survival temperature - 40 °C (other temperature ranges on request)
Bypass setting:	Δp 3.5 bar \pm 10 %
Filter head material:	GAL
Filter housing material:	AL/St.
Sealing material:	NBR/AL
Maintenance indicator setting:	Δp 2.2 bar \pm 10 %
Electrical data of maintenance indicator:	
Max. voltage:	250 V AC/200 V DC
Max. current:	1 A
Contact load:	70 W
Type of protection:	IP 65 in inserted and secured status
Contact:	normally open/closed
Cable connection:	M20x1.5

The switching function can be changed by turning the electric upper part by 180° (normally closed contact or normally open contact). The state on delivery is a normally closed contact. By inductivity in the direct current circuit the use of suitable protection circuit should be considered. Further maintenance indicator details and designs are available in the maintenance indicator data sheet.

We draw attention to the fact that all values indicated are average values which do not always occur in specific cases of application. Our products are continually being further developed. Values, dimensions and weights can change as a result of this. Our specialized department will be pleased to offer you advice.

We recommend to contact us concerning applications of our filters in areas governed by the EU Directive 94/9 EC (ATEX 95). The standard version can be used for liquids based on mineral oil (corresponding to the fluids in Group 2 of Directive 97/23 EC Article 9). If you consider to use other fluids please contact us for additional support.

Subject to technical alteration without prior notice.

9. Dimensions

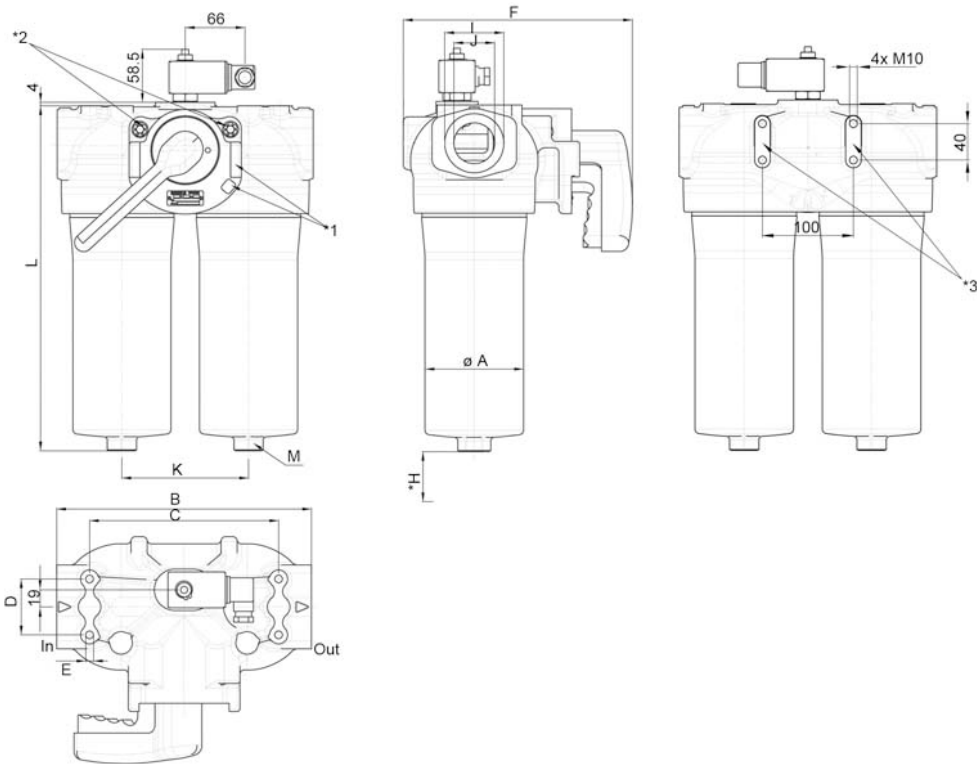

In Inlet

Out Outlet

*H Minimum clearance required for element change

*1 Lever locking and arresting

*2 Venting screws

*3 Optional wall mounting for NG 160 up to 400

All dimensions except "J" in mm.

Type	øA	B	C	D	E	F	G	H	øI	J*	K	L	M SW	Wt. [kg]
Pi 21004	66	172	100	52	M8x16	189	130	80	47	G1	85	203	27	2.6
Pi 21006	66	172	100	52	M8x16	189	130	80	47	G1	85	261	27	2.9
Pi 21010	66	172	100	52	M8x16	189	130	80	47	G1	85	351	27	3.3
Pi 21016	109	283	210	62	M10x20	252	194	110	65	G1½	140	288	32	8.6
Pi 21025	109	283	210	62	M10x20	252	194	110	65	G1½	140	389	32	9.5
Pi 21040	109	283	210	62	M10x20	252	194	110	65	G1½	140	531	32	19.0

* SAE flange connections (3000 psi), NPT and SAE connections on request

10. Installation, operating and maintenance instructions

10.1 Filter installation

When installing filter make sure that sufficient space is available to remove filter element and filter housing.

Preferably the filter should be installed with the filter housing pointing downwards.

The maintenance indicator must be visible.

10.2 Connecting the electrical maintenance indicator

The electrical indicator is connected via a 2-pole appliance plug according to DIN EN 175301-803 with poles marked 1 and 2. The electrical section can be inverted to change from normally open to normally closed position or vice versa. The state on delivery is a normally closed contact.

10.3 When should the filter element be replaced?

1. Filters equipped with visual and electrical maintenance indicator:
During cold starts, the indicator may give a warning signal. Press the red button of the visual indicator once again only after operating temperature has been reached. If the red button immediately pops up again and/or the electrical signal has not switched off after reaching operating temperature the filter element must be replaced after the end of the shift.
2. Please always ensure that you have original MAHLE spare elements in stock: Disposable elements cannot be cleaned.

10.4 Element replacement

Note: Elements may only be replaced by people who are familiar with the function of the filter. When replacing elements, appropriate safety clothing (protective goggles, gloves, safety shoes) must be worn.

Note: The maintenance indicator monitors the filter side in operation, which is identified by the position of the switching lever catch. The change-over transfer valve must be switched prior filter servicing. Now the signal of the maintenance indicators cancelled and the red button can be repressed again:

1. Operate and hold pressure equalizing lever located behind switching lever. Pull catch knob and swivel switching lever. Engage the catch on the clear filter side. Place through or drip pan underneath to collect leaving oil.
2. Loosen vent screw of the filter side not in use by 2-3 turns; max. until contact is made with the safety stop.
3. Unscrew filter housing by rotating same counter-clockwise and clean with a suitable medium.
Warning: The shift lever may not, from now until the screwing back in of the filter housing (7.), be activated under any circumstances!
4. Remove filter element with a side-to-side motion.
5. Check O-ring on the filter house for damage. Replace, if necessary.
6. Make sure that the order number on the spare element corresponds to the order number of the filter name-plate.
7. Lightly lubricate the threads of the filter housing and screw into the filter head. Maximum tightening torque for NG 40 to 100 = 60 Nm, for NG 160 to 400 = 100 Nm.
8. To refill the filter chamber, operate only the pressure equalizing lever (leave the switching lever arrested in its catch) long enough for the medium to emerge bubble-free from the vent bore.
9. Tighten vent screw. Check filter for leaks by operating the pressure equalizing lever once again.

11. Spare parts list

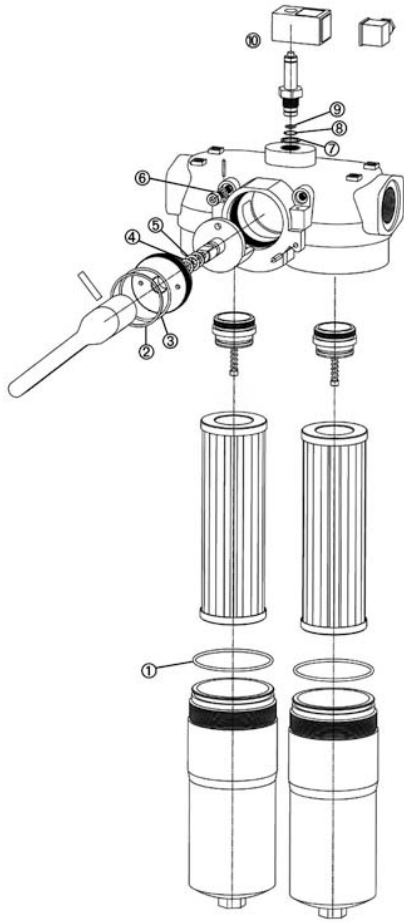

Order number for spare parts		
Position	Type	Order number
① bis ⑥	Seal kit for housing	
	Pi 21004 - Pi 21010	
	NBR	79774258
	FPM	79774266
	EPDM	79774274
	Pi 21016 - Pi 21040	
	NBR	79774282
	FPM	79774290
⑦ bis ⑨	Seal kit for maintenance indicator	
	NBR	77760309
	FPM	77760317
	EPDM	77760325
⑩	Maintenance indicator	
	Visual PiS 3098/2.2	77669971
	Electrical PiS 3097/2.2	77669948
	Electrical upper section only	77536550

MAHLE Industriefiltration GmbH
Schleifbachweg 45
D-74613 Öhringen
Phone +49 7941 67-0
Fax +49 7941 67-23429
industrialfiltration@mahle.com
www.mahle-industrialfiltration.com
79336280.09/2012