

MAHLE

Industry

Automatic metal-edge filter

AF 71 H

with radial scraper cleaning
High-pressure design up to 400 bar

1. Features

MAHLE automatic metal-edge filters are suitable for all applications where low or high-viscosity liquids or pastes have to be filtered and homogenised.

These compact, inline filter systems are designed for automatic cleaning. The system is cleaned by rotating the filter element against a spring actuated scraper.

Advantages:

- Extended filter service life due to the use of a cleanable element
- Cleaning is possible without interrupting filtration
- Precise separation quality in accordance with the metal-edge principle
- Sturdy filter element made of triangular stainless steel wire on a rugged core element
- Efficient filter cleaning assures maximum process stability
- Solid construction and high-quality materials for a long service life
- Optimal filter selection
- Material variants open up a wide range of applications
- Easy maintenance
- Worldwide distribution



2. Operating principle

The MAHLE AF 71 H is a special type of metal-edge filter. The MAHLE metal-edge filter system with an operating pressure up to 400 bar is used to filter and homogenise a wide range of liquids and pastes.

This compact, inline filter system consumes no filter material, which means there is also no need for subsequent disposal. The filter is cleaned automatically, semi-automatically or manually without interrupting operation. The concentrated solids are drained off simply by opening the system for a short time.

The medium to be cleaned is guided into the filter housing under pressure or in suction mode. It flows inward through the MAHLE filter element. The solids are separated on the surface of the triangular filter element wires. The filtered fluid exits the filter housing at the top opposite the inlet connection.

The filter is cleaned either when a preset differential pressure limit is reached or after a specified cycle time elapses. The MAHLE filter element is rotated against a spring actuated scraper for this purpose. The special gap geometry of the filter element guarantees efficient cleaning.

The particles or agglomerates are skimmed from the surface and settle in the collection cone. The patented filter element bearing (AKF system) prevents high axial forces and facilitates the cleaning process.

The residue that has settled in the collection plenum can be emptied via the drain valve either when the machine is at a standstill or during filtration if there are moderate pressure conditions.

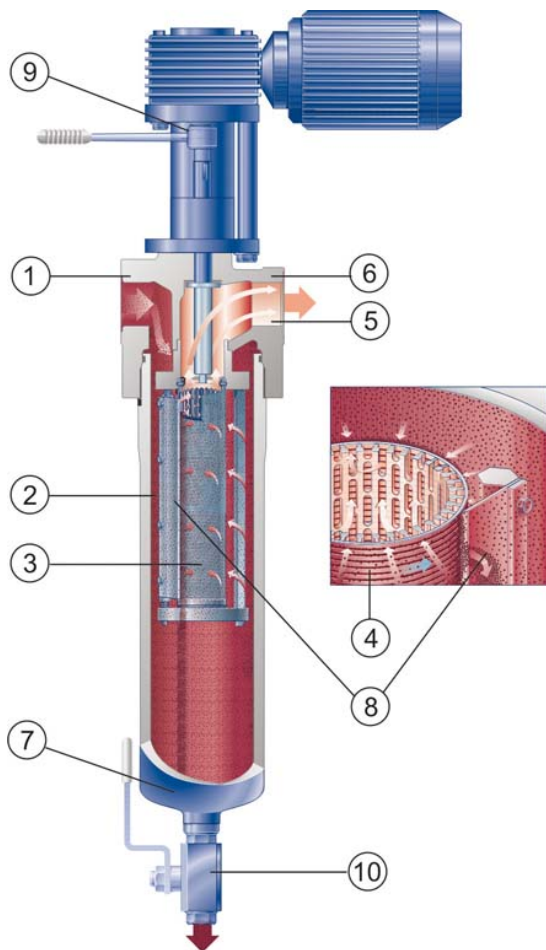

Used MAHLE filter elements in the AF 71 H metal-edge filter:

MAHLE coiled element (standard):

- Optimum cleaning by means of sharp-edged triangular wire
- Large effective filter surface
- Small, precise gap widths
- High differential pressure stability and torsional strength
- Several material combinations possible

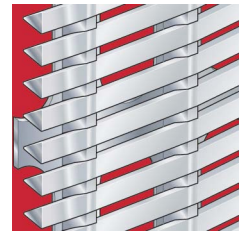

MAHLE welded element:

- High wear resistance to abrasive media
- Sturdy trapezoidal wire for high-viscosity media
- Welded design
- Manufactured in stainless steel

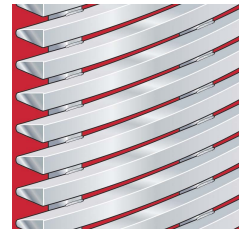

- 1 Inlet connection
- 2 Inlet plenum
- 3 MAHLE filter element
- 4 Triangular wire winding
- 5 Plenum for filtered fluid
- 6 Outlet connection
- 7 Particle collection plenum
- 8 Scraper
- 9 Cleaning drive with gear motor or hand ratchet
- 10 Drain valve manual

3. Technical data

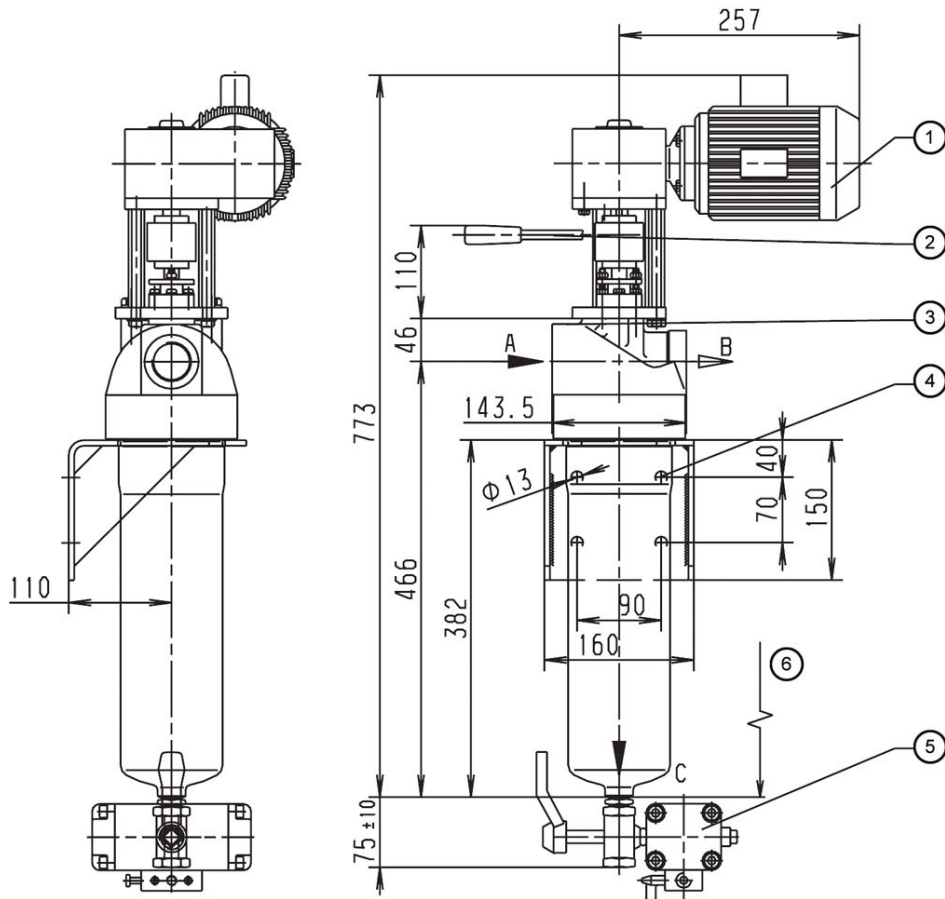

- 1 Cleaning drive, worm gear motor can be mounted at each 90° position
- 2 Ratchet optional
- 3 Name-plate
- 4 Mounting holes Ø13
- 5 Drain valve manual, automatic mode optional
- 6 Clearance required = 260 mm

Optional: differential pressure switch

Filter data

- Max. operating pressure: 400 bar
- Max. operating temperature: 100 °C
- Materials:
- Filter head: Nodular cast iron 40
 - Filter bowl: Ck 15
 - Internals: St. 1.4301, nodular cast iron
 - Bearing bushes: PTFE based
 - Seals: FPM (Viton)
 - Coiled element: 1.4571 or 1.4571/AI (Δp max. 40 bar)
 - Welded element: 1.4571 (Δp max. 10 bar)

Connections and nominal diameters:

- A-inlet, B-outlet: G1¼
- C-drain: G½
- All threaded holes acc. to DIN 3852 form X

Drive shaft seal: Cup seal packing and O-ring

Outside coating: Synthetic resin primer, blue acc. to RAL 5007

Motor data

Worm gear motor
Multi-range winding

V	Hz	kW	rpm	A
Δ 230 ± 10%	50	0.18	17	1.2
λ 400 ± 10%	50	0.18	17	0.7
Δ 266 ± 10%	60	0.22	21	1.2
λ 460 ± 10%	60	0.22	21	0.7

Protection class: IP55, insulation class F; output torque: 52 Nm

Optional: Ex Protection acc. to ATEX 94/9/EC

- Electrical design in Ex II 2G T3
- Mechanical design in Ex II 2G c T3

Weight: 10 kg (with ratchet) or 14 kg (with motor)

Volume: 2.5 l

Other types available on request!

Technical data is subject to change without notice!

4. Design and application

Element type (see section 6)	Total surface in cm ²	Gap width in μm/ effective filter surface in cm ²															
		30	40	50	60	80	100	130	160	200	250	360	500	1000	1500	2000	
AF 7013	230	14	18	22	26	33	40	50	59	69	81	102	121	162	182	194	
AF 7033	230	14	18	22	26	33	40	50	59								
AF 7073	230						22	28	33	40	49	64	81	121	146	162	
AF 7083	230			15	18	23	29	36	43	51	61	79	97	139	162	177	

 Recommended design

Cleaning and emptying

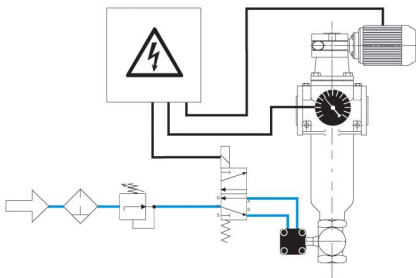

Operation mode:

Filtration usually takes place under pressure. The filter is cleaned after a programmed time or a preset number of cycles or according to the differential pressure. We recommend cleaning the system at approximately 4 times the initial differential pressure. The cleaning motor is operated for around 10 seconds (about three turns of the filter element). This is sufficient to clean the filter thoroughly. The motor may need to run continuously in exceptional cases. The drive shaft is always turned clockwise.

The drain valve is opened in order to empty the filter. Depending on the residue concentration, this can either take place synchronously with cleaning or be time or cycle controlled.

The opening time of the drain valve can be between 2 and 6 seconds. The filter can be emptied in suction mode using a buffer or by interrupting the filtration process.

Semi-automatic and manual operation are also possible.



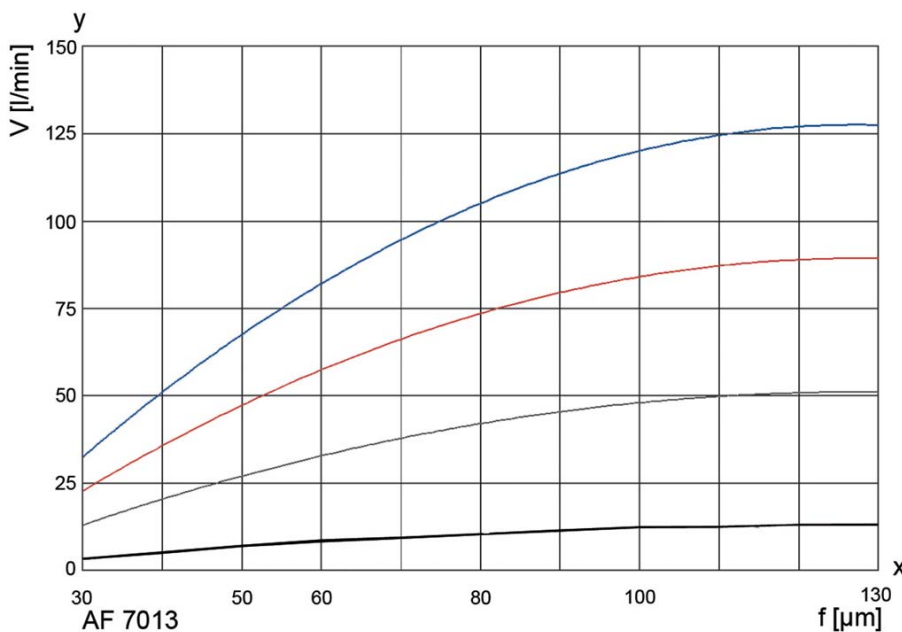

Refer to the Instruction Manual for further information.

5. Efficiency curves



The curves indicate the volume flow through the complete filter system (filter housing including element) and are referred to a differential pressure of 0.3 bar. Specific process information is essential to guarantee reliable operation of an automatic filter

Viscosity in mm²/s

-  1 mm²/s
-  33 mm²/s
-  100 mm²/s
-  500 mm²/s

y = Volume flow V [l/min]
x = Gap width f [μm]
mm²/s = cst

6. Type number key

Type number key with selection example for AF 7132-1691-60101/H1

Size

AF 713 1 x 42x190 No. of steps x diameter x length [mm]

Cleaning drive

- 2 Ratchet
- 3 Gear motor 230/400 V, 50 Hz or 266/460 V, 60 Hz
- 4 Gear motor 230/400 V, 50 Hz Ex II 2G T3

Inlet and outlet connections

16 G1¼

Permissible operating pressure in bar (housing/cover)

9 PN 400

Material Seal FPM, bearing PTFE

- 1 Housing and cover nodular cast iron, steel, aluminium
- 3 Housing and cover steel, grey cast iron or nodular cast iron, internals stainless steel 1.4301/1.4571

Differential pressure indicator

- 6 PIS 3192, switching level at 2.2 bar, static 450 bar
- 7 PIS 3192, switching level at 5 bar, static 450 bar

Valves and control throttles for AF 11, 13, 15, 17

0 Without/special version

Drain valve

- 1 Ball valve, manual
- 2 Ball valve, electropneumatic 24 V DC
- 3 Ball valve, electropneumatic 230 V AC
- 4 Ball valve, electric 24 V DC
- 5 Ball valve, electric 230 V AC

Cleaning valve

0 Without/special version

Optional features

- 0 Without/special version
- 1 Bypass valve 20 bar

AF 713 2 -16 9 1 -6 0 1 0 1 -XXXX (end number for special version)/H1

End number	Special version
3700	PTFE seals
Other numbers	On request

Type number key with selection example for coiled or welded elements for AF 70

Series						/E1
AF 70	Coiled or welded element with triangular wire winding					
	Material	Core element	Filter medium	Clamp rings	Wire width in mm	
	Coiled element					
	1	Al	1.4571	1.4571	0.5	
	3	1.4581	1.4571	-	0.5	
	Welded element					
	7	-	1.4571	1.4571	1	
	8	-	1.4571	1.4571	0.75	
	Overall length Diameter x length in mm					
	3	42x190				
	Gap width/rating in µm (see 4. Design and application)					
	003	30 µm	010	100 µm	036	360 µm
	004	40 µm	013	130 µm	050	500 µm
	005	50 µm	016	160 µm	100	1000 µm
	006	60 µm	020	200 µm	150	1500 µm
	008	80 µm	025	250 µm	200	2000 µm
	Other filter ratings on request					
AF 70	1	3	-010			/E1

7. Spare parts

No.	Designation	Material no.	
		FPM/C steel	PTFE/VA
1	Bush kit		79797184
2	Seal kit (complete)	79797176	
3	Scraper		78389447
4	Filter element	See name-plate	

Please contact us for detailed technical information, any open questions about options, accessories and for general expert advice. Completion of the relevant questionnaire would facilitate in the coordination of all important parameters.

Comprehensive documentation on our filter range, filter elements and accessories can be provided. About installation and operation, please refer to the Instruction Manual

MAHLE Industriefiltration GmbH
 Schleifbachweg 45
 74613 Öhringen
 Phone +49 7941 67-0
 Fax +49 7941 67-23429
 industrialfiltration@mahle.com
 www.mahle-industriefiltration.com
 76122550.03/2012